



City of Enid
401 W. Owen K. Garriott Road
Enid, Oklahoma 73701
580-234-0400

BOARD OF COMMISSIONERS

NOTICE OF MEETINGS

Mayor and Board of Commissioners of the City of Enid, Oklahoma, the Trustees of the Enid Municipal Authority, a Public Trust, the Trustees of the Enid Economic Development Authority, a Public Trust, and the Trustees of the Enid Public Transportation Authority, a Public Trust

Notice is hereby given that the Mayor and Board of Commissioners of the City of Enid, Oklahoma, the Trustees of the Enid Municipal Authority, a Public Trust, the Trustees of the Enid Economic Development Authority, a Public Trust, and the Trustees of the Enid Public Transportation Authority, a Public Trust will meet in regular session at 6:30 p.m. on the 19th day of June, 2018, in the Council Chambers of the City Administration Building, located at 401 W. Owen K. Garriott Road in said city, and the agenda for said meeting is as follows:

- AGENDA -

MAYOR AND BOARD OF COMMISSIONERS REGULAR MEETING

1. CALL TO ORDER/ROLL CALL.
2. INVOCATION.
3. FLAG SALUTE.
4. CONSIDER APPROVAL OF MINUTES OF THE REGULAR COMMISSION MEETING OF JUNE 5, 2018.
5. AWARDS, PRESENTATIONS, PROCLAMATIONS, AND ORGANIZATIONAL BUSINESS.
 1. PRESENT PET AVAILABLE FOR ADOPTION AT THE CITY ANIMAL SHELTER.
 2. RECOGNITION OF COLONEL DARRELL F. JUDY.
 3. RECOGNITION OF MAYOR BILL SHEWEY FOR RECEIVING THE 2018 CITIZEN OF THE YEAR AWARD FROM THE GREATER ENID CHAMBER OF COMMERCE.
 4. APPOINTMENTS OF CITY COMMISSIONERS TO THE WALK OF FAME COMMITTEE AND THE ENID REGIONAL DEVELOPMENT ALLIANCE (ERDA).

6. ADMINISTRATION.

- 1. HOLD A PUBLIC HEARING TO CONSIDER A REQUEST TO CLOSE A PORTION OF A UTILITY EASEMENT LOCATED IN LOT 14, BLOCK 13, PLAT OF BLOCKS THIRTEEN AND FOURTEEN WILDERNESS COVE, PART OF THE NORTHWEST QUARTER, SECTION TEN, TOWNSHIP TWENTY-TWO NORTH, RANGE SEVEN WEST, INDIAN MERIDIAN.**
 - 2. CONSIDER AN ORDINANCE CLOSING TO THE PUBLIC A PORTION OF A UTILITY EASEMENT LOCATED IN LOT 14, BLOCK 13, PLAT OF BLOCKS THIRTEEN AND FOURTEEN WILDERNESS COVE, PROVIDING FOR REPEALER, SAVINGS CLAUSE, AND SEVERABILITY.**
 - 3. CONSIDER A RESOLUTION AMENDING THE 2017-2018 HEALTH FUND BUDGET BY APPROPRIATING ADDITIONAL FUNDS IN THE AMOUNT OF \$400,000.00 TO INCREASE THE 2017-2018 APPROPRIATED AMOUNTS FOR THE HEALTH DEPARTMENT.**
 - 4. CONSIDER A RESOLUTION AUTHORIZING A GENERAL FUND TRANSFER IN THE AMOUNT OF \$350,000.00 TO THE FIRE DEPARTMENT.**
 - 5. CONSIDER A RESOLUTION AMENDING THE 2017-2018 GENERAL FUND BUDGET BY APPROPRIATING ADDITIONAL FUNDS IN THE AMOUNT OF \$245,000.00 TO INCREASE THE 2017-2018 APPROPRIATED AMOUNTS FOR THE GENERAL FUND SALES TAX TRANSFERS DEPARTMENT.**
 - 6. CONSIDER THE PHASING OPTIONS FOR THE KAW LAKE PROGRAM AND TAKE ANY NECESSARY ACTION.**
- 7. CONSENT.**
- 1. AWARD PURCHASE OF ONE 2018 LEEBOY 1000G PAVER FOR THE PUBLIC WORKS DIVISION FROM KIRBY-SMITH MACHINERY, INC., OKLAHOMA CITY, OKLAHOMA, IN THE AMOUNT OF \$89,500.00.**
 - 2. AWARD PURCHASE OF ONE 2019 FREIGHTLINER M2106 WITH BERGKAMP POTHOLE PATCHER FOR THE PUBLIC WORKS DIVISION FROM HOUSTON FREIGHTLINER, HOUSTON, TEXAS, IN THE AMOUNT OF \$187,670.00 .**
 - 3. AWARD PURCHASE OF ONE JOHN BEAN SJ704020 JETTER FOR THE PUBLIC WORKS DIVISION, FROM FRONTIER EQUIPMENT, YUKON, OKLAHOMA, IN THE AMOUNT OF \$54,434.22.**
 - 4. AWARD CONTRACT FOR REMOTE SCHOOL BEACON MONITORING SYSTEM TO GADES SALES COMPANY, INC., WICHITA, KANSAS, IN THE AMOUNT OF \$116,308.00, AND AUTHORIZE THE MAYOR TO EXECUTE ALL CONTRACT DOCUMENTS.**

5. RENEW THE ADMINISTRATIVE SERVICES AGREEMENT BETWEEN THE CITY OF ENID AND BLUECROSS BLUESHIELD OF OKLAHOMA FOR THIRD PARTY ADMINISTRATION OF THE CITY OF ENID'S SELF FUNDED EMPLOYEE HEALTH INSURANCE PLAN AND DENTAL PLAN, PROVIDE COBRA ADMINISTRATION AND ADD STOP LOSS COVERAGE.
6. ACCEPT PUBLIC HIGHWAY EASEMENT FROM EDUARDO ARMAS AND MEGAIN ARMAS, GARFIELD COUNTY, OKLAHOMA, AND AUTHORIZE PAYMENT FOR RIGHT OF WAY ON CLEVELAND STREET AT BURLINGTON NORTHERN SANTA FE (BNSF) RAIL ROAD, IN THE AMOUNT OF \$9,030.00.
7. APPROVE CHANGE ORDER NO. 1 WITH LUCKINBILL, INC., ENID, OKLAHOMA, FOR THE 1900 BLOCK OF EAST BROADWAY AVENUE, BOX CULVERT REPLACEMENT PROJECT NO. F-1703C, IN THE AMOUNT OF \$3,935.88.
8. AWARD A CONTRACT TO LUCKINBILL, INC., ENID, OKLAHOMA FOR THE 2018 SANITARY SEWER VIDEO INSPECTIONS PROJECT NO. S-1801B, IN THE AMOUNT OF \$244,148.32, AND AUTHORIZE THE MAYOR TO EXECUTE ALL CONTRACT DOCUMENTS.
9. APPROVE GROUND WATER LEASE BETWEEN WILLOW LAKE OWNERS ASSOCIATION AND THE CITY OF ENID.
10. APPROVAL OF CLAIMS IN THE AMOUNT OF \$2,882,449.50.
8. RECESS TO CONVENE AS THE ENID MUNICIPAL AUTHORITY.
9. TRUSTEES OF THE ENID MUNICIPAL AUTHORITY REGULAR MEETING.
10. ENID MUNICIPAL AUTHORITY REGULAR MEETING.
1. CONSIDER A RESOLUTION INCREASING THE 2017-2018 FISCAL FINANCIAL PLAN FOR THE ENID MUNICIPAL AUTHORITY IN THE AMOUNT OF \$150,000.00.
2. AUTHORIZE PAYMENTS TO CIMARRON TERRACE WATER ASSOCIATION FOR UNDER PRODUCTION OF UNIT 4 AND UNIT 6 IN AMES WATER FIELD FOR 2013 THROUGH 2017.
3. CONSIDER AND TAKE ACTION WITH RESPECT TO A RESOLUTION AGREEING TO FILE APPLICATION(S) WITH THE OKLAHOMA WATER RESOURCES BOARD (THE "OWRB") FOR FINANCIAL ASSISTANCE THROUGH OWRB FINANCIAL ASSISTANCE PROGRAM AND THROUGH THE DRINKING WATER STATE REVOLVING FUND LOAN PROGRAM, WITH THE LOAN PROCEEDS BEING FOR THE PURPOSE OF FINANCING CERTAIN WATER SYSTEM IMPROVEMENTS; AND CONTAINING OTHER PROVISIONS RELATED THERETO.
4. APPROVAL OF CLAIMS IN THE AMOUNT OF \$888,531.82.
11. ADJOURN TO CONVENE AS THE ENID ECONOMIC DEVELOPMENT AUTHORITY.

12. TRUSTEES OF THE ENID ECONOMIC DEVELOPMENT AUTHORITY REGULAR MEETING.
13. ENID ECONOMIC DEVELOPMENT AUTHORITY REGULAR MEETING.
 1. APPROVAL OF CLAIMS IN THE AMOUNT OF \$12,508.86.
14. ADJOURN TO CONVENE AS THE ENID PUBLIC TRANSPORTATION AUTHORITY.
15. TRUSTEES OF THE ENID PUBLIC TRANSPORTATION AUTHORITY REGULAR MEETING.
16. ENID PUBLIC TRANSPORTATION AUTHORITY REGULAR MEETING.
 1. APPROVAL OF CLAIMS IN THE AMOUNT OF \$3,588.50.
17. ADJOURN TO RECONVENE AS THE ENID CITY COMMISSION.
18. PUBLIC COMMENTS.
19. CONSIDER CONVENING INTO EXECUTIVE SESSION TO DISCUSS AN ECONOMIC DEVELOPMENT PROPOSAL INVOLVING THE CITY'S WASTEWATER TREATMENT PLANT; AND TO DISCUSS NEGOTIATIONS WITH ENID/GARFIELD COUNTY FRATERNAL ORDER OF POLICE LODGE #144 AND AMERICAN FEDERATION OF STATE, COUNTY AND MUNICIPAL EMPLOYEES (AFSCME) LOCAL #1136; AND TO DETERMINE WHETHER TO JOIN IN RE: NATIONAL PRESCRIPTION OPIATE LITIGATION, AND TO DISCUSS CITY OF ENID V. FREDDIE AND MARY KATHRYN LORENZ, 2013-49, AND RECONVENE INTO REGULAR SESSION TO TAKE ANY NECESSARY ACTION.
20. ADJOURN.

City Commission Meeting

4.

Meeting Date: 06/19/2018

SUBJECT:

CONSIDER APPROVAL OF MINUTES OF THE REGULAR COMMISSION MEETING OF JUNE 5, 2018.

Attachments

Minutes

MINUTES OF REGULAR MEETING OF THE
MAYOR AND BOARD OF COMMISSIONERS OF THE CITY OF ENID, OKLAHOMA,
TRUSTEES OF THE ENID MUNICIPAL AUTHORITY, A PUBLIC TRUST,
TRUSTEES OF THE ENID ECONOMIC DEVELOPMENT AUTHORITY, A PUBLIC TRUST,
AND TRUSTEES OF THE ENID PUBLIC TRANSPORTATION AUTHORITY, A PUBLIC TRUST
HELD ON THE 5TH DAY OF JUNE 2018

The Mayor and Board of Commissioners of the City of Enid, County of Garfield, State of Oklahoma, the Trustees of the Enid Municipal Authority, a Public Trust, the Trustees of the Enid Economic Development Authority, a Public Trust, and the Trustees of the Enid Public Transportation Authority, a Public Trust, met in regular session at 6:30 P.M. on the 5th day of June 2018, in the Council Chambers of the Administration Building of the City of Enid, located at 401 West Owen K. Garriott Road in said city, pursuant to notice given by December 15, 2017 to the Clerk of the City of Enid, and pursuant to notice thereof displayed at the entrance to the Administration Building of said city, in prominent view and which notice was posted prior to 5:00 P.M. on the 4th day of June 2018.

-MAYOR AND BOARD OF COMMISSIONERS-

Mayor Shewey called the meeting to order with the following members present and absent:

PRESENT: Commissioners Janzen, Norwood, Ezzell, Waddell, Wilson, Pankonin and Mayor Shewey.

ABSENT: None.

Staff present were City Manager Jerald Gilbert, City Attorney Carol Lahman, City Clerk Alissa Lack, Chief Financial Officer Erin Crawford, Director of Engineering Services Christopher Gdanski, City Engineer Robert Hitt, Public Utilities Director Louis Mintz, Public Works Director Everett Glenn, Planning Administrator Chris Bauer, Police Captain Bryan Skaggs, Fire Chief Joe Jackson, Director of Marketing and Public Relations Steve Kime, Human Resources Director Sonya Key, and Ex-Officio Member Chief Master Sergeant Robert Johnson.

Commissioner Derwin Norwood, Jr., gave the Invocation, and Commissioner Tammy Wilson led the Flag Salute.

Motion was made by Commissioner Janzen and seconded by Commissioner Waddell to approve the minutes of the special Commission meetings of May 7, 2018 and May 10, 2018, and the rescheduled regular meeting of May 22, 2018, and the vote was as follows:

AYE: Commissioners Janzen, Norwood, Ezzell, Waddell, Wilson, Pankonin and Mayor Shewey.

NAY: None.

Animal Adoption Coordinator Charlet Ringwald presented "Dorian", a 2-year-old male Terrier/Chihuahua mix available for adoption at the Enid Animal Shelter.

A Proclamation was read and presented proclaiming June 21, 2018 as "Dump the Pump Day".

A Proclamation was read and presented proclaiming June 5, 2018 as "Lowe's Home Improvement Corporate Citizen Recognition Day".

A public hearing was held regarding a request to close a portion of an undeveloped street east of Lot 1, Block 8, East Park Addition to Enid, Oklahoma.

City Engineer Robert Hitt spoke regarding the proposed closure, explaining that the request was to close a portion of 7th Street. He provided an illustration showing a residence at the location and a fenced area and driveway located in the street easement. These structures had existed since 1984, but it had been determined that they existed in the street right-of-way. The travel path that had been used to access the property was located on the park property. The residents, in an effort to clear up their title, had requested the closure of this portion of 7th Street. When the property owners purchased the property in

1984, their understanding was that this was all part of the property. Notice had been sent to property owners within three-hundred feet of the location and utility companies, to notify them of the proposed closing. The only comment was from a utility company and was that there was a street light on the north side of the property that received power from the alley, but a utility easement was being retained.

Following brief discussion, the hearing concluded.

Mr. Hitt explained that this item was an action item to provide for adoption of an ordinance to close a portion of 7th Street. He noted that the City's sanitary sewer would still be protected by the retention of a utility easement, but the property owner could go to district court and acquire title for said easement.

Motion was made by Commissioner Wilson and seconded by Commissioner Janzen to adopt an ordinance closing to the public a portion of an undeveloped street east of Lot 1, Block 8, East Park Addition to Enid, Oklahoma; providing for repealer, savings clause, and severability, and the vote was as follows:

AYE: Commissioners Janzen, Norwood, Ezzell, Waddell, Wilson, Pankonin and Mayor Shewey.

NAY: None.

ORDINANCE NO. 2018-17

AN ORDINANCE CLOSING TO THE PUBLIC A PORTION OF AN UNDEVELOPED STREET EAST OF LOT 1, BLOCK 8, EAST PARK ADDITION TO ENID OKLAHOMA, PROVIDING FOR REPEALER, SAVINGS CLAUSE, AND SEVERABILITY.

Commissioner Ezzell spoke regarding a proposed ordinance amendment that would permit the use of skateboards in the downtown area and noted that there was an ordinance that prohibited tampering with public or private property or that prohibited injury, defacing or destroying any real property and another ordinance regarding obstruction of streets and sidewalks. If the commission chose to revoke the

original ordinance [regarding skateboards], there would still be ordinances that protected property owners and business owners everywhere from anyone improperly using skateboards.

Motion was made by Commissioner Ezzell and seconded by Commissioner Waddell to adopt an ordinance amending the Enid Municipal Code 2014, Title 6, “Motor Vehicles and Traffic”, Chapter 10, “Bicycles and Play Vehicles”, Section 6-10-8 “Skateboards, In-Line Skates, Coasters, and Roller Skates” to allow skateboard use downtown unless prohibition is posted; providing for repealer, savings clause, severability and codification, and the vote was as follows:

AYE: Commissioners Janzen, Norwood, Ezzell, Waddell, Wilson, Pankonin and Mayor Shewey.

NAY: None.

ORDINANCE NO. 2018-18

AN ORDINANCE AMENDING THE ENID MUNICIPAL CODE 2014, TITLE 6, “MOTOR VEHICLES AND TRAFFIC”, CHAPTER 10, “BICYCLES AND PLAY VEHICLES”, SECTION 6-10-8 “SKATEBOARDS, IN-LINE SKATES, COASTERS, AND ROLLER SKATES” TO ALLOW SKATEBOARD USE DOWNTOWN UNLESS PROHIBITION IS POSTED; PROVIDING FOR REPEALER, SAVINGS CLAUSE, SEVERABILITY AND CODIFICATION.

Motion was made by Commissioner Ezzell to adopt an ordinance amending the Enid Municipal Code 2014, Title 6, “Motor Vehicles and Traffic”, Chapter 1, “General Traffic Provisions” Section 6-1-2 “Definitions” to add “Electric Personal Assistive Mobility Device”; and amending Chapter 13 “Low Speed Electrical Vehicles, Golf Carts, Minibikes, and All-Terrain Vehicles”, to create Section 6-13-5 “Electric Personal Assistive Mobility Devices” to allow for use upon city streets and trails; providing for repealer, savings clause, severability and codification.

Motion was seconded by Commissioner Waddell and the vote was as follows:

AYE: Commissioners Janzen, Norwood, Ezzell, Waddell, Wilson, Pankonin and Mayor Shewey.

NAY: None.

A public hearing was held regarding the Fiscal Year 2018 Annual Action Plan to consider \$418,584.00 allocation as recommended by the Mayor and Board of Commissioners for the Community Development Block Grant (CDBG) Program.

CDBG Coordinator Stephanie Carr explained that the funding commission, which was made up of three City commissioners and two at-large members, met and made recommendations for said funds. After administration and Section 108 were taken, it was recommended that parks in a low-moderate income area receive \$20,000; CDSA, for emergency repairs, receive \$72,922; and Booker T. Washington Youth Program, Making A Difference Youth Program, and Zoe Kids' Café Youth Program each receive \$20,929.33.

Ms. Yvonne Lewis-Odom, 4415 Sandhill Drive, addressed commissioners and expressed gratitude for recognizing forty-plus years that the Booker T. Washington Community Center had served the community, and noted that commissioners could look forward to something exciting coming out of Booker T. Washington.

Following brief discussion, the hearing concluded.

Ms. Carr explained that all of the recommendations noted during the hearing would be included in the Five-Year Consolidated Plan, and if approved, she would submit the plan the next business day.

Motion was made by Commissioner Waddell and seconded by Commissioner Pankonin to approve a resolution adopting the Fiscal Year 2018-2022 Five-Year Consolidated Plan and the 2018 Annual Action Plan for the Community Development Block Grant Program and Budget for the 2018-2019 Program Year, and authorize the CDBG Director to submit the plan to the Department of Housing and Urban Development, and the vote was as follows:

AYE: Commissioners Janzen, Norwood, Waddell, Wilson, Pankonin and Mayor Shewey.

NAY: None.

Commissioner Ezzell was absent from the vote.

Motion was made by Commissioner Ezzell and seconded by Commissioner Waddell to approve staff recommendations, on the following consent items as listed, and the vote was as follows:

AYE: Commissioners Janzen, Norwood, Ezzell, Waddell, Wilson, Pankonin and Mayor Shewey.

NAY: None.

- (1) Acceptance of an amendment to Surface Water Permit 2014-047, schedule of use, from the Oklahoma Water Resource Board (OWRB);
- (2) Acceptance of permit from the Oklahoma Department of Environmental Quality for Project No. W-1801, to relocate a waterline to service Broadway Avenue;
- (3) Acceptance of permit from the Oklahoma Department of Environmental Quality for Project No. W-1804, to relocate a waterline in the 600 to 800 block of West Elm Street;
- (4) Acceptance of permit from the Oklahoma Department of Environmental Quality for Project No. W-1813A, to extend the waterline near the Chisholm School;
- (5) Approval of contract award for Project No. F-1801C, Paved Channel From Chestnut Avenue to The Waller School Property, to the lowest responsible bidder, EMC Services LLC, Oklahoma City, Oklahoma, in the amount of \$427,720.00, and authorize the Mayor to execute all contract documents;
- (6) Approval of contract award for Project No. W-1814C, 2018 Local Streets Program, Waterline Improvements, to the lowest responsible bidder, SMC Utility Construction, Oklahoma City, Oklahoma, in the amount of \$253,662.00, and authorize the Mayor to execute all contract documents;
- (7) Approval of contract award for Project No. M-1805, ADA Compliance Program at Coolidge Elementary School, to the lowest responsible bidder, MTZ Construction, Oklahoma City, Oklahoma, in the amount of \$318,974.00, and authorize the Mayor to execute all contract documents;
- (8) Award of contract for Project No. R-1802C, 2018 Arterial Street Program, to the lowest responsible bidder, Cummins Construction Company, Inc., Enid, Oklahoma, in the amount of \$578,622.97, and authorize the Mayor to execute all contract documents;
- (9) Approval of Change Order No. 3 with Layne Christensen Company for Project No. W-1512A, Well Field Improvements Project, to add a production well and 5,000 lateral feet of six inch raw waterline, in the amount of \$267,350.00, resulting in a total revised contract amount of \$1,769,333.00;
- (10) Approval of Change Order No. 1 with Cummins Construction Company, Inc., for Project No. R-1802C, to add additional units to extend the work for approximately one and half

blocks, in the amount of \$138,161.78, resulting in a revised contract amount of \$716,784.75;

- (11) Approval of second amendment to the contract with the Guernsey for the development of a comprehensive plan and transportation plan, for a savings of \$14,336.00, which reduces the total contract amount to \$381,449.00;
- (12) Approval of execution of a contract with the Oklahoma Department of Corrections for the Annual Prisoners' Public Works Project (PPWP) from July 1, 2018 to June 30, 2019;

(Copy Resolution)

- (13) Allowance of the following claims for payment as listed:

(List Claims)

Chairman Shewey adjourned the meeting to convene as the Enid Municipal Authority.

- TRUSTEES OF THE ENID MUNICIPAL AUTHORITY -

PRESENT: Trustees Janzen, Norwood, Ezzell, Waddell, Wilson, Pankonin, Chairman Shewey, Trust Manager Jerald Gilbert, Trust Attorney Carol Lahman and Secretary Alissa Lack.

ABSENT: None.

Motion was made by Trustee Ezzell and seconded by Trustee Pankonin to allow the following claims for payment as listed, and the vote was as follows:

AYE: Trustees Janzen, Norwood, Ezzell, Waddell, Wilson, Pankonin and Chairman Shewey.

NAY: None.

(List Claims)

Chairman Shewey adjourned the meeting to convene as the Enid Economic Development Authority.

- TRUSTEES OF THE ENID ECONOMIC DEVELOPMENT AUTHORITY -

PRESENT: Trustees Janzen, Norwood, Ezzell, Waddell, Wilson, Pankonin, Chairman Shewey, Trust Manager Jerald Gilbert, Trust Attorney Carol Lahman, and Secretary Alissa Lack.

ABSENT: None.

Motion was made by Trustee Waddell and seconded by Trustee Pankonin to allow the following claims for payment as listed, and the vote was as follows:

AYE: Trustees Janzen, Norwood, Ezzell, Waddell, Wilson, Pankonin and Chairman Shewey.

NAY: None.

(List Claims)

Chairman Shewey adjourned the meeting to convene as the Enid Public Transportation Authority.

- TRUSTEES OF THE ENID PUBLIC TRANSPORTATION AUTHORITY -

PRESENT: Trustees Janzen, Norwood, Ezzell, Waddell, Wilson, Pankonin, Chairman Shewey, General Manager Jerald Gilbert, Trust Attorney Carol Lahman and Secretary Alissa Lack.

ABSENT: None.

Motion was made by Commissioner Ezzell and seconded by Commissioner Janzen to approve a resolution authorizing the Enid Public Transportation Authority to apply with the Oklahoma Department of Transportation, Transit Programs Division, for a Grant under 49 U.S.C. Section 5339(B), Bus and Bus Facilities Grant Program for funds during the 2018-2019 Fiscal Program Year, and the vote was as follows:

AYE: Trustees Janzen, Norwood, Ezzell, Waddell, Wilson, Pankonin and Chairman Shewey.

NAY: None.

(Copy Resolution)

Motion was made by Trustee Pankonin and seconded by Trustee Ezzell to allow the following claims for payment as listed, and the vote was as follows:

AYE: Trustees Janzen, Norwood, Ezzell, Waddell, Wilson, Pankonin and Chairman Shewey.

NAY: None.

(List Claims)

Chairman Shewey adjourned the meeting to reconvene as the Enid City Commission.

- MAYOR AND BOARD OF COMMISSIONERS -

Ms. Diane Levesque, 1324 West Oak Avenue, addressed Commissioners regarding Dump the Pump Day, sidewalks downtown and problems with those sidewalks, a commercial television station for Enid, and Fireball Run.

Motion was made by Commissioner Ezzell to convene into Executive Session to discuss an economic development proposal involving the City's wastewater treatment plant; pending actions on the Hall leases and the Walton conveyance; and pending litigation, Cimarron Terrace Water Association v. Enid Municipal Authority and Oklahoma Water Resources; to determine whether to join in RE: National Prescription Opiate Litigation.

Motion was seconded by Commissioner Waddell, and the vote was as follows:

AYE: Trustees Janzen, Norwood, Ezzell, Waddell, Wilson, Pankonin and Chairman Shewey.

NAY: None.

The meeting convened into Executive Session at 7:04 P.M.

In Executive Session, the Commission discussed an economic development proposal involving the City's wastewater treatment plant; pending actions on the Hall leases and the Walton conveyance; and pending litigation, Cimarron Terrace Water Association v. Enid Municipal Authority and Oklahoma Water Resources; to determine whether to join in RE: National Prescription Opiate Litigation.

Motion was made by Commissioner Ezzell and seconded by Commissioner Waddell to reconvene into regular session, and the vote was as follows:

AYE: Trustees Janzen, Norwood, Ezzell, Waddell, and Pankonin.

NAY: None.

Commissioner Wilson and Mayor Shewey were absent from the vote.

The meeting reconvened into regular session at 8:36 P.M.

There being no further business to come before the Board at this time, motion was made by Commissioner Ezzell and seconded by Commissioner Waddell that the meeting adjourn, and the vote was as follows:

AYE: Commissioners Janzen, Norwood, Ezzell, Waddell, and Pankonin.

NAY: None.

Commissioner Wilson and Mayor Shewey were absent from the vote.

The meeting adjourned at 8:36 P.M.

City Commission Meeting

5.2.

Meeting Date: 06/19/2018

SUBJECT:

RECOGNITION OF COLONEL DARRELL F. JUDY.

City Commission Meeting

5.3.

Meeting Date: 06/19/2018

SUBJECT:

**RECOGNITION OF MAYOR BILL SHEWEY FOR RECEIVING THE 2018 CITIZEN OF THE YEAR
AWARD FROM THE GREATER ENID CHAMBER OF COMMERCE.**

City Commission Meeting

5.4.

Meeting Date: 06/19/2018

Submitted By: Alissa Lack, City Clerk

SUBJECT:

APPOINTMENTS OF CITY COMMISSIONERS TO THE WALK OF FAME COMMITTEE AND THE ENID REGIONAL DEVELOPMENT ALLIANCE (ERDA).

BACKGROUND:

Members of the Board of Commissioners serve on various City boards and committees. All appointments are made by the City Commission with the exception of the Metropolitan Area Planning Commission, which is made by the Mayor.

The boards listed below each require an appointment for one vacancy. Mayor Shewey is recommending that the following appointments be made:

Enid Regional Development Alliance - Commissioner Jonathan Waddell, replacing Commissioner Ben Ezzell

Walk of Fame Committee - Mayor Bill Shewey, Commissioner Derwin Norwood, and Commissioner George Pankonin

RECOMMENDATION:

Consider appointments.

PRESENTER:

William E. Shewey, Mayor

City Commission Meeting

6.1.

Meeting Date: 06/19/2018

Submitted By: Jacqueline Cook, Engineering EA

SUBJECT:

HOLD A PUBLIC HEARING TO CONSIDER A REQUEST TO CLOSE A PORTION OF A UTILITY EASEMENT LOCATED IN LOT 14, BLOCK 13, PLAT OF BLOCKS THIRTEEN AND FOURTEEN WILDERNESS COVE, PART OF THE NORTHWEST QUARTER, SECTION TEN, TOWNSHIP TWENTY-TWO NORTH, RANGE SEVEN WEST, INDIAN MERIDIAN.

BACKGROUND:

This is a companion to item 6.2.

The Engineering Department has received a request from Matt and Heather Easley to close a portion of a utility easement: (809 Caribou Circle) - the south six (6) feet of the north sixteen (16) feet, of the west 126.29 feet of Lot 14, Block 13 as shown on the recorded Plat of Blocks Thirteen and Fourteen Wilderness Cove; Part of the Northwest Quarter, Section 10, Township 22 North, Range 7 West, Indian Meridian.

Being more particularly described as: Commencing at the northwest corner of Lot 14, Block 13, Plat of Blocks Thirteen and Fourteen Wilderness Cove; Thence south along the west property line of said Lot to a point that is ten (10) feet from the north line of said Lot measured perpendicular thereto, point of beginning; Thence east parallel to the north property line of said Lot to a point that is ten (10) feet west of the east line of said Lot measured perpendicular thereto; Thence south parallel to the east line of said Lot to a point sixteen (16) feet south of said north line of said Lot measured perpendicular thereto; Thence west parallel to said north line to the west line of said Lot; Thence north along the west line of said Lot a distance of six (6) feet to the point of beginning.

Reason for closing: As a family of 5, we need additional space for our children for activity and study areas. The layout of our house on the property makes it impossible to add space to the bedrooms on the west side of the property. The east side of our property is the best location for a building addition, but given the current layout of our home, it is unfeasible as one would have to pass through the master bedroom to access the addition. Our immediate needs are for separate study/play areas to the north, and better access to the east side of our property for outdoor activity. Furthermore, there are currently no utilities located within the easement, and since the easement does not extend to the east of our property (nor the west of neighboring property), it is highly unlikely that there will ever be any in the future. We respectfully request the closure of the south six feet of the easement, leaving the easement ten feet wide.

The Metropolitan Area Planning Commission (MAPC) reviewed this request at its meeting on June 18, 2018.

Pursuant to Section 7-1-4 of the Enid Municipal Code, 2003, all utility companies and property owners within three hundred feet (300') of the road to be closed have been notified of this Hearing.

RECOMMENDATION:

Conduct a Hearing.

PRESENTER:

Robert Hitt, P.E., City Engineer.

Attachments

Closing location map



Location Map

Proposed Closing Portion of Easement

809 Caribou Circle

City Commission Meeting

6.2.

Meeting Date: 06/19/2018

Submitted By: Jacqueline Cook, Engineering EA

SUBJECT:

CONSIDER AN ORDINANCE CLOSING TO THE PUBLIC A PORTION OF A UTILITY EASEMENT LOCATED IN LOT 14, BLOCK 13, PLAT OF BLOCKS THIRTEEN AND FOURTEEN WILDERNESS COVE, PROVIDING FOR REPEALER, SAVINGS CLAUSE, AND SEVERABILITY.

BACKGROUND:

This is a companion to item 6.1. The closing of the portion of easement will allow for beneficial use of the property.

RECOMMENDATION:

Pending outcome of Public Hearing, Approve Ordinance.

PRESENTER:

Robert Hitt, P.E., City Engineer.

Attachments

Ordinance

ORDINANCE NO. 2018-20

AN ORDINANCE CLOSING TO THE PUBLIC A PORTION OF A UTILITY EASEMENT LOCATED IN LOT 14, BLOCK 13, OF PLAT BLOCKS THIRTEEN AND FOURTEEN WILDERNESS COVE, PROVIDING FOR REPEALER, SAVINGS CLAUSE, AND SEVERABILITY.

ORDINANCE

BE IT ORDAINED BY THE MAYOR AND BOARD OF COMMISSIONERS OF THE CITY OF ENID, OKLAHOMA:

Section 1: Public way closed. The required notices of hearing of this Ordinance having been given, the public way concerning 809 Caribou Circle, Enid, Garfield County, Oklahoma is described as follows:

A portion of a utility easement: the south six (6) feet of the north sixteen (16) feet, of the west 126.29 feet of Lot 14, Block 13 as shown on the recorded Plat of Blocks Thirteen and Fourteen Wilderness Cove, a part of the Northwest Quarter of Section Ten, Township Twenty-two North, Range Seven West of the Indian Meridian, being more particularly described as follows:

Commencing at the northwest corner of Lot 14, Block 13, Blocks Thirteen and Fourteen Wilderness Cove; Thence south along the west property line of said Lot to a point that is ten (10) feet from the north line of said Lot measured perpendicular thereto, point of beginning; Thence east parallel to the north property line of said Lot to a point that is ten (10) feet west of the east line of said Lot measured perpendicular thereto; Thence south parallel to the east line of said Lot to a point sixteen (16) feet south of said north line of said Lot measured perpendicular thereto; Thence west parallel to said north line to the west line of said Lot; Thence north along the west line of said Lot a distance of six (6) feet to the point of beginning.

Section 2: The public alleys, streets, and public ways listed above are hereby approved to be closed to public use except the City of Enid shall retain the absolute right to reopen the public way without expense and that the closing shall not affect the right to maintain, repair, construct, operate a public easement access or facility, until such time as action is brought in the District Court pursuant to Title 11, Oklahoma Statutes, Section 42-101, *et seq.*

Section 3: Repealer. All ordinances or parts thereof, which are inconsistent with this ordinance, are hereby repealed.

Section 4: Savings Clause. Nothing in this ordinance hereby adopted shall be construed to affect any suit or proceedings now pending in any court, or any rights acquired or liability incurred, nor any cause or causes of action accrued or existing, under any act or ordinance repealed hereby. Nor shall any right or remedy of any character be lost, impaired or affected by this ordinance.

Section 5: Severability. If any one or more of the sections, sentences, clauses or parts of this ordinance, chapter or section shall, for any reason, be held invalid, the invalidity of such section, clause or part shall not affect or prejudice in any way the applicability and validity of any other provision of this ordinance. It is hereby declared to be the intention of the City Commission of the City of Enid that this Ordinance would have been adopted had such unconstitutional, illegal or invalid sentence, clause, section or part not been included.

PASSED AND APPROVED this 19th day of June, 2018.

City of Enid, Oklahoma

William Shewey, Mayor

(SEAL)

ATTEST:

Alissa Lack, City Clerk

Approved as to Form and Legality:

Carol Lahman, City Attorney

City Commission Meeting

6.3.

Meeting Date: 06/19/2018

Submitted By: Erin Crawford, Chief Financial Officer

SUBJECT:

CONSIDER A RESOLUTION AMENDING THE 2017-2018 HEALTH FUND BUDGET BY APPROPRIATING ADDITIONAL FUNDS IN THE AMOUNT OF \$400,000.00 TO INCREASE THE 2017-2018 APPROPRIATED AMOUNTS FOR THE HEALTH DEPARTMENT.

BACKGROUND:

The 2017-2018 healthcare claims budget of \$4,405,360.00 is projected to exceed appropriations by \$400,000.00 for the current fiscal year due to a very high employee healthcare claims year. The City has stop loss insurance that would pay when claims exceed 125% of projected claims for the year in aggregate, but it is not anticipated that claims will reach the 125% level. Therefore, this appropriation is necessary.

There are funds available to appropriate from the Health Fund balance.

RECOMMENDATION:

Approve resolution.

PRESENTER:

Erin Crawford, Chief Financial Officer.

Fiscal Impact

Budgeted Y/N: N
Amount: \$400,000.00
Funding Source:
Health Fund Balance

Attachments

Resolution

RESOLUTION

A RESOLUTION AMENDING THE 2017-2018 HEALTH FUND BUDGET BY APPROPRIATING ADDITIONAL FUNDS IN THE AMOUNT OF \$400,000.00 TO INCREASE THE 2017-2018 APPROPRIATED AMOUNTS FOR THE HEALTH DEPARTMENT.

WHEREAS, the current fiscal year has been an exceptionally high employee healthcare claims for the City's self-insured health plan; and

WHEREAS, health claims for fiscal 2017-2018 are projected to approximate \$4,925,172.36. The 2017-2018 health claims budget is \$4,405,360.00; and

WHEREAS, due to other savings in the budget, the projected budget deficit is \$400,000.00. The appropriated amounts for the 2017-2018 Health Department in the Health Fund must be increased by an additional \$400,000.00 to provide funding; and

WHEREAS, funds are available from the Health Fund balance to provide the necessary funding;

AND NOW, THEREFORE, BE IT RESOLVED BY THE MAYOR AND BOARD OF COMMISSIONERS OF THE CITY OF ENID, OKLAHOMA, THAT THE CITY OF ENID 2017-2018 BUDGET BE AMENDED TO INCREASE THE APPROPRIATIONS FOR THE HEALTH FUND HEALTH DEPARTMENT:

FUND 14 HEALTH FUND	
Health Department	\$400,000.00

Adopted this 19th day of June 2018.

Mayor

(Seal)

ATTEST:

City Clerk

City Commission Meeting

6.4.

Meeting Date: 06/19/2018

Submitted By: Erin Crawford, Chief Financial Officer

SUBJECT:

CONSIDER A RESOLUTION AUTHORIZING A GENERAL FUND TRANSFER IN THE AMOUNT OF \$350,000.00 TO THE FIRE DEPARTMENT.

BACKGROUND:

The General Fund is projected to complete the current fiscal year within budgeted appropriations and has available funds to transfer \$350,000.00 in support of future equipment purchases for the Fire Department.

RECOMMENDATION:

Approve resolution.

PRESENTER:

Erin Crawford, Chief Financial Officer.

Fiscal Impact

Budgeted Y/N: N
Amount: \$350,000.00
Funding Source:
General Fund

Attachments

Resolution

RESOLUTION

A RESOLUTION AUTHORIZING A GENERAL FUND TRANSFER OUT OF \$350,000.00 TO THE FIRE FUND.

WHEREAS, funds in the amount of \$350,000 have been repurposed to the General Fund Transfer Department; and

WHEREAS, the Fire Fund is projected to have a budgeted deficit during the current year and the funds provided will go toward the future purchase of a triple combination pumper at an anticipated cost of \$700,000.00; and

WHEREAS, funds are available to be transferred from the General Fund to the Fire Fund to provide the necessary funding;

AND NOW, THEREFORE, BE IT RESOLVED BY THE MAYOR AND BOARD OF COMMISSIONERS OF THE CITY OF ENID, OKLAHOMA, THAT THE CITY OF ENID 2017-2018 BUDGET BE AMENDED TO AUTHORIZE A GENERAL FUND TRANSFER OUT:

FUND 10 GENERAL FUND	
General Fund Transfers Department	\$350,000.00

Adopted this 19th day of June 2018.

Mayor

(Seal)

ATTEST:

City Clerk

City Commission Meeting

6.5.

Meeting Date: 06/19/2018

Submitted By: Erin Crawford, Chief Financial Officer

SUBJECT:

CONSIDER A RESOLUTION AMENDING THE 2017-2018 GENERAL FUND BUDGET BY APPROPRIATING ADDITIONAL FUNDS IN THE AMOUNT OF \$245,000.00 TO INCREASE THE 2017-2018 APPROPRIATED AMOUNTS FOR THE GENERAL FUND SALES TAX TRANSFERS DEPARTMENT.

BACKGROUND:

Sales tax revenues are projected to come in approximately \$245,000.00 or 1.76% higher than budgeted for the 2017-2018 fiscal year. The appropriations in the General Fund Sales Tax Transfers department must be increased to transfer out the associated revenues to the Enid Municipal Authority for the portion associated with the 1% capital improvement sales tax and the 1% Kaw Lake sales tax.

Funds are available to appropriate for current year sales tax revenues.

RECOMMENDATION:

Approve resolution.

PRESENTER:

Erin Crawford, Chief Financial Officer.

Fiscal Impact

Budgeted Y/N: N

Amount: \$245,000.00

Funding Source:

General Fund Sales Tax Revenues

Attachments

Resolution

RESOLUTION

A RESOLUTION AMENDING THE 2017-2018 GENERAL FUND BUDGET BY APPROPRIATING ADDITIONAL FUNDS IN THE AMOUNT OF \$245,000.00 TO INCREASE THE 2017-2018 APPROPRIATED AMOUNTS FOR THE GENERAL FUND SALES TAX TRANSFERS DEPARTMENT.

WHEREAS, sales taxes in the general fund are projected to be approximately 1.76% higher than budgeted for fiscal year 2017-2018; and

WHEREAS, the appropriated amounts for the 2017-2018 General Fund Sales Tax Transfers Department in the General Fund must be increased by an additional \$245,000.00 to transfer sales tax revenues to the Enid Municipal Authority; and

WHEREAS, sales tax funds collected during the 2017-2018 fiscal year and are available to be transferred from the General Fund to the Enid Municipal Authority;

AND NOW, THEREFORE, BE IT RESOLVED BY THE MAYOR AND BOARD OF COMMISSIONERS OF THE CITY OF ENID, OKLAHOMA, THAT THE CITY OF ENID 2017-2018 BUDGET BE AMENDED TO INCREASE THE APPROPRIATIONS FOR THE GENERAL FUND GENERAL FUND SALES TAX TRANSFERS DEPARTMENT:

FUND 10 GENERAL FUND	
Sales Tax Transfers Department	\$245,000.00

Adopted this 19th day of June 2018.

Mayor

(Seal)

ATTEST:

City Clerk

City Commission Meeting

6.6.

Meeting Date: 06/19/2018

Submitted By: Jacqueline Cook, Engineering EA

SUBJECT:

CONSIDER THE PHASING OPTIONS FOR THE KAW LAKE PROGRAM AND TAKE ANY NECESSARY ACTION.

BACKGROUND:

The Phase II of the Kaw Lake Program has identified six configuration options to allow for the successful execution of the program to meet the current water demands and maintain the capability to grow the water supply system to meet several future growth scenarios.

The pipeline configurations considered include 30-inch and 36-inch pipes, intermediate booster pump stations and the systems initial capacity identified in Million Gallons per Day (MGD).

The Water Treatment Plant (WTP) options include flocculation, sedimentation, filtration, ozone (O3), and Granular Activated Charcoal (GAC) and the systems initial capacities identified in Million Gallons per Day (MGD).

Option	Pipeline	WTP	Estimated Cost	Initial Capacity
1	30" at 7 MGD	7 MGD, Ozone & GAC	\$291M	7 MGD
2	30" at 7 MGD	10.5 MGD, O3 & GAC	\$299M	7 MGD
3	36" at 9.2 MGD	10.5 MGD, GAC	\$299M	9.2 MGD
4	30" at 10.5 MGD	10.5 MGD, O3 & GAC	\$305M	10.5 MGD
5	36" at 7 MGD	7 MGD, O3 & GAC	\$307M	7 MGD
6	36" at 9.2 MGD	10.5 MGD, O3 & GAC	\$315M	9.2 MGD

Engineering has recommended either Option #4 or #6 to provide water conveyance system capacity and a robust water treatment system to meet the City's current water demands with sufficient growth capacity.

RECOMMENDATION:

Consider the options and take any actions necessary.

PRESENTER:

Christopher Gdanski, Director of Engineering.

City Commission Meeting

7.1.

Meeting Date: 06/19/2018

Submitted By: Kelley Munkres, Administrative Assistant

SUBJECT:

AWARD PURCHASE OF ONE 2018 LEEBOY 1000G PAVER FOR THE PUBLIC WORKS DIVISION FROM KIRBY-SMITH MACHINERY, INC., OKLAHOMA CITY, OKLAHOMA, IN THE AMOUNT OF \$89,500.00.

BACKGROUND:

The Oklahoma State Purchasing Contract SW195 with Kirby-Smith Machinery, Inc., provided a quote of \$89,500.00 for an asphalt paver for street repair projects within the City.

This asphalt paver is appropriate for use by Public Works and the state price is competitive. Utilizing the state list alleviates the need for the City to pursue its own competitive bidding.

RECOMMENDATION:

Award paver purchase to Kirby-Smith Machinery, Inc. in the amount of \$89,500.00.

PRESENTER:

Everett Glenn, Public Works Director

Fiscal Impact

Budgeted Y/N: N

Amount: \$89,500.00

Funding Source:

General Fund Capital Equipment Department

Attachments

Quote

Specs

Pictures

SW195

Contact Info



05/10/2018

Quote #: mwolf-1358

PURCHASE THROUGH OKLAHOMA SW195

Everett Glenn
CITY OF ENID
PO Box 1768
Enid, OK 73702

Dear Mr. Glenn:

We are pleased to quote the following for your consideration:

NEW LEEBOY 1000G 2018 model w/ 0 hours, Unit # N.I.S., S/N Factory Order.

The following Factory and Dealer Options are included in the package:

- 1000G Paver
- All 1000G Pavers, Enclosed Tier 4 Final Engine, Tilt-Hopper designed material delivery system, 8' to 13' hydraulically-extendable LP Screed, vibrating and heated legend screed with four burners, Digital Display with gauge package: oil pressure and water temperature gauges, volt meter, tachometer, hour meter, horn, back-up alarm, lockable fuel and hydraulic caps, Spraydown system, Low Deck profile, one seat, and amber safety strobe light
- Fail-safe Brake
- Hose Reel
- Sonic Auger, Sensors, and Cords
- Standard Warranty – One Year / 1000 hours (whichever comes 1st)

Deal Summary:

Sales Price: \$89,500.00
(includes delivery to City of Enid)

We believe the equipment as quoted will exceed your expectations. On behalf of Kirby-Smith Machinery, Inc., thank you for the opportunity to quote LeeBoy machinery.

Sincerely,

Mike Wolf
Governmental Territory Manager
Office phone: 405-495-7820
Cell Phone: 405-439-0620
mwolf@kirby-smith.com

**This proposal is good for 30 days*

**Subject to prior sale and machine availability*

**Pricing is based on a 'Cash Sale' and will require revised pricing if purchased through any buyer consortiums (Not limited to but such as, HGAC, Buy Board or State Contractor Associations)*

www.kirby-smith.com | 888-861-0219

Oklahoma City * Tulsa * Dallas * Fort Worth * Abilene * Amarillo * Lubbock * Odessa * St. Louis * Kansas City

1000G Asphalt Paver Specifications



Dimensions	<ul style="list-style-type: none"> - Length: 9' 6" (2.9 m) - Width: 8' 6" (2.59 m) transport 9' (2.7 m) hopper wings down - Height: 7' (2.13 m) - Total Weight: 11,000 lbs. (4,990 kg) 	Operator's Platform	Full machine width platform, left side seat
Engine	Kubota turbocharged diesel, Tier 4 Final – 49 hp (37 kw)	Operator's Controls	<ul style="list-style-type: none"> - All control levers are on left side - Right side levers include left/right drive control, right auger, right screed extension hopper
Capacities	<ul style="list-style-type: none"> - Fuel: 13.5 gallons (51 l) - Hydraulic reservoir: 45 gallons (170 l) 	Steering	- Independent hydrostatic steering from left or right side of machine
Hopper	Hopper size: 5.5 ton (4,900 kg)	Washdown System	Electric pump with two hoses
Paving Widths	- Machine has variable paving widths from 1" to 13' (.0254 m to 3.926 m)	Push Rollers	Two rollers with sealed bearings
Paving Depths	- Depth: 0" to 6" (.152 m)	Track Drive System	<ul style="list-style-type: none"> - Hydrostatically powered, self-cleaning friction drive tracks - Track size: 14" wide x 4' long (.356 x 1.219 m) steel (wheel base) - Paving speed: 0 to 220' per minute (2.5 mph) - Travel speed: 0 to 220' per minute (2.5 mph)
Screed	<ul style="list-style-type: none"> - Legend full free floating screed - Consisting of a main screed and two hydraulically operated screed extensions - Equipped with a hydraulic vibrator 	Additional Standard Equipment	<ul style="list-style-type: none"> - Back-up alarm - Rotating safety beacon - Lockable fuel and hydraulic caps - Electric gauge package (oil pressure, voltmeter, fuel)
Screed Heat	<ul style="list-style-type: none"> - Two propane burners on main screed - One propane burner on each extension 	Optional Equipment	<ul style="list-style-type: none"> - Right hand sea - LED working light package - Sonic grade controls - 20' (6.096 m) ski - Two-speed track drive - Fail-safe brake - Umbrella - Hose reel
Screed Crown/Valley	<ul style="list-style-type: none"> - Equipped with a crown/valley adjustment - Includes a depth indicator for the operator 		
Material Handling	<ul style="list-style-type: none"> - Two independent hydraulically operated under auger material cut-off gates - Two independent hydraulically operated cast augers 		



BUILT BY LISTENING
KNOWLEDGE
EXPERTISE

VT LeeBoy, Inc. ■ 500 Lincoln County Parkway Extension ■ Lincolnton, NC 28092 ■ 704.966.3300
For additional products or information, visit our website: www.LeeBoy.com

BR-1001.0-EN This document contains information applicable for the U.S. and U.S. Territories. For International product availability, specifications and support, please contact your authorized LeeBoy representative. The technical data contained herein is subject to change due to continuous engineering and development. Accordingly, LeeBoy Group reserves the right to modify at any time.



1000G Asphalt Paver

LeeBoy



Small footprint, large results. The gravity-feed tilt hopper featured on the 1000G can be raised to a steeper level than any other paver in its class allowing for optimum material flow. This paver boasts of a sleek design in which the hopper wings can be retracted. This dynamic feature allows continuous material flow while reducing the machine's overall width. As on all LeeBoy pavers, this smaller track paver features our superior Legend Screed system that is proven to supply one of the best mats in the industry.

Performance Features:

- 49 hp (37 kw) Kubota Tier 4 Final Diesel Engine
- Paving Widths 1" to 13' (25.4 mm to 3.926 m)
- Low Deck Configuration
- Best-In-Class Tilt Hopper Angle
- Single Lever Hopper and Wing Control
- Ultra-efficient Material Management System
- Under Auger Material Cut-Off Gates
- 5.5 Ton (4,900 kg) Capacity Material Hopper
- Steel Track for Superior Flotation
- Proven Legend Screed System
- Heated and Vibrating Screed System



**ATTACHMENT M
PAVER**

Type of Equipment	Brand Name	Model	Price Book/Catalog Date of Manufacturer's Current Published Retail Price List	Percentage off discount %
1000G Paver	LeeBoy	1000KUB	\$85,900	5%
Options:				
Two-Speed Track Drive *Requires the selection of Fail-safe Brake			\$5,200	
Fail-safe Brake			\$1,750	
Sonic Auger, Sensors, and Cords			\$4,900	
LED Work Light Package (4 lights)			\$1,250	
Hose Reel (Limited to 1)			\$800	
Electric Screws for Grade Controls			\$2,475	
Wiring Only, Grade Controls (Topcon) includes A M Modules *Requires the selection of electric screws			\$3,975	
Sonic Grade Control One Side (Topcon) *Requires the selection of electric screws			\$9,975	

Attachments/Accessories: _____% OEM Repair Parts: _____% Options: _____%

Multiple Unit discount: _____% (In addition to the equipment discount) based on _____ Units purchased

Extended Warranty offered? ____Yes ____No If yes, please attach information for the extended warranty purchase. Discount offered _____%

Contact Information

Website: www.kirby-smith.com

Company Name	Kirby-Smith Machinery, Inc.
Doing Business as (if applicable)	
Contact Person for Solicitation Response	Bill Gustafson
Phone	405-495-7820
Email	bgustafson@kirby-smith.com
Fax	405-787-5973
Address For Purchase Orders-Number & Street-Post Office Box (some companies have ordering addresses that are different than the payment address)	<p>Physical Address: 6715 W. Reno Ave, Oklahoma City, OK 73127</p> <p>Billing Address: PO BOX 270300, Oklahoma City, OK 73137</p>
City, State, Zip	Oklahoma City, OK 73127
Contact Person for Contract/Ordering/Price Information/Equipment Additions/Changes/Discontinuations	
Contact Name	Bill Gustafson
Phone	405-495-7820
Fax	405-787-5973
Email	bgustafson@kirby-smith.com
Secondary Contact for Contract/Ordering	Nancy Pinkerton
Phone	405-495-7820 / 405-7827197 direct
Fax	405-787-5973
Email	npinkerton@kirby-smith.com
Address For Payment-Number & Street-Post Office Box (some companies have a different Payment/remittance address than the ordering address)	PO BOX 270300
City, State, Zip	Oklahoma City, OK 73137
Contact Person/Department for payment	Tim Kline, Credit Manager
Phone	405-495-7820
Fax	405-787-5973
Email	tkline@kirby-smith.com
Early Payment Discount (i.e. 15 days)	Net N/A days
Supplier will be responsible for notifying the contracting officer when the contact information changes.	Notes: (Special ordering instructions-please attach any special instructions on a separate sheet)

City Commission Meeting

7.2.

Meeting Date: 06/19/2018

Submitted By: Kelley Munkres, Administrative Assistant

SUBJECT:

AWARD PURCHASE OF ONE 2019 FREIGHTLINER M2106 WITH BERGKAMP POTHOLE PATCHER FOR THE PUBLIC WORKS DIVISION FROM HOUSTON FREIGHTLINER, HOUSTON, TEXAS, IN THE AMOUNT OF \$187,670.00 .

BACKGROUND:

The City needs a freightliner with pothole patcher to assist with street repair projects within the City. HGACBuy contract number HT06-18 with Houston Freightliner provided a quote of \$187,670.00.

This pothole patcher is appropriate for use by Public Works and the contract price is competitive. Utilizing the contract price with HGACBuy alleviates the need for the City to pursue its own competitive bidding.

RECOMMENDATION:

Award purchase to Houston Freightliner in the amount of \$187,670.00.

PRESENTER:

Everett Glenn, Public Works Director

Fiscal Impact

Budgeted Y/N: N

Amount: \$187,670.00

Funding Source:

General Fund Capital Equipment Department

Attachments

Contract Pricing
Freightliner Specs
Pothole Patcher



CONTRACT PRICING WORKSHEET
For MOTOR VEHICLES Only

Contract No.: HT06-18

Date Prepared: 5/14/2018

This Worksheet is prepared by Contractor and given to End User. If a PO is issued, both documents MUST be faxed to H-GAC @ 713-993-4548. Therefore please type or print legibly.

Buying Agency:	City of Enid	Contractor:	Houston Freightliner
Contact Person:	Everett Glenn	Prepared By:	Adam Neuse
Phone:	580-348-0528	Phone:	713-580-8188
Fax:		Fax:	713-676-1603
Email:		Email:	adam.neuse@strhouston.com

Product Code:	C5	Description:	2019 Freightliner M2 106 SRA
---------------	----	--------------	------------------------------

A. Product Item Base Unit Price Per Contractor's H-GAC Contract: 61652

B. Published Options - Itemize below - Attach additional sheet(s) if necessary - Include Option Code in description if applicable.
(Note: Published Options are options which were submitted and priced in Contractor's bid.)

Description	Cost	Description	Cost
B6.7 240 HP 560 LB FT TQ	1466	200 Amp 28-SI Quadramaont Alternator	103
Allison 3000 RDS Atu Trans	5089	Battery Disconnect MTD LH of Driver Seat	131
RS-23-160 23000 LB RR Axle	591	Horton Drive Master On/Off Fan Drive	28
192" Wheelbase	649	700 Watt/ 115 Volt Block Heater	65
11/32x3-1/2x10-5/16" Frame 120 KSI	139		
RH Understep Aftertreatment w/ Vert Stack	617		
LH/RH Dome Light w/ 3 Way Switch	62		
Basic High Back Air Driver Seat	159		
Basic High Back Air Passenger Seat	198		
Adjustable Steering Column	359	Bergkamp FP5 Flameless Pathcer	114570
AM/FM Radio w/ Bluetooth	299	Subtotal From Additional Sheet(s):	
Aux Rocker Switch Dash Mounted	82	Subtotal B:	124607

C. Unpublished Options - Itemize below / attach additional sheet(s) if necessary.
(Note: Unpublished options are items which were not submitted and priced in Contractor's bid.)

Description	Cost	Description	Cost
		Subtotal From Additional Sheet(s):	
		Subtotal C:	0

Check: Total cost of Unpublished Options (C) cannot exceed 25% of the total of the Base Unit Price plus Published Options (A+B). **For this transaction the percentage is:** 0%

D. Total Cost Before Any Applicable Trade-In / Other Allowances / Discounts (A+B+C)

Quantity Ordered:	1	X Subtotal of A + B + C:	186259	=	Subtotal D:	186259
-------------------	---	--------------------------	--------	---	-------------	--------

E. H-GAC Order Processing Charge (Amount Per Current Policy) Subtotal E: 1500

F. Trade-Ins / Special Discounts / Other Allowances / Freight / Installation / Miscellaneous Charges

Description	Cost	Description	Cost
Discount	-89		
		Subtotal F:	-89

Delivery Date: **G. Total Purchase Price (D+E+F):** 187670

Prepared for:
Everett Glenn
City of Enid
401 West Owen K Garriott
Enid, OK 73702
Phone: 580-348-0528

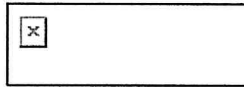

Prepared by:
Michael McCarthy
HOUSTON FREIGHTLINER,
WESTERN STAR
9550 NORTH LOOP EAST
HOUSTON, TX 77029
Phone: 713-580-8122
E-Mail:
mmccarthy@strhouston.com

*A proposal for
City of Enid*

*Prepared by
HOUSTON FREIGHTLINER, WESTERN STAR
Michael McCarthy*

Apr 19, 2018

Freightliner M2 106

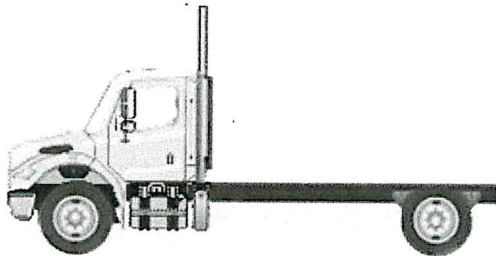

Components shown may not reflect all spec'd options and are not to scale

Prepared for:
 Everett Glenn
 City of Enid
 401 West Owen K Garriott
 Enid, OK 73702
 Phone: 580-348-0528

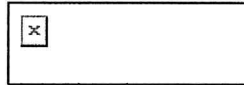

Prepared by:
 Michael McCarthy
 HOUSTON FREIGHTLINER,
 WESTERN STAR
 9550 NORTH LOOP EAST
 HOUSTON, TX 77029
 Phone: 713-580-8122
 E-Mail:
 mmccarthy@strhouston.com

S P E C I F I C A T I O N P R O P O S A L

Data Code	Description	Weight Front	Weight Rear
Price Level			
PRL-17M	M2 PRL-17M (EFF:11/14/17)		
Data Version			
DRL-001	SPECPRO21 DATA RELEASE VER 001		
Vehicle Configuration			
001-172	M2 106 CONVENTIONAL CHASSIS	5,759	3,503
004-219	2019 MODEL YEAR SPECIFIED		
002-004	SET BACK AXLE - TRUCK		
019-002	STRAIGHT TRUCK PROVISION		
003-001	LH PRIMARY STEERING LOCATION		
General Service			
AA1-002	TRUCK CONFIGURATION		
AA6-002	DOMICILED, USA (EXCLUDING CALIFORNIA AND CARB OPT-IN STATES)		
A85-010	UTILITY/REPAIR/MAINTENANCE SERVICE		
A84-1GM	GOVERNMENT BUSINESS SEGMENT		
AA4-005	BUILDING MATERIAL COMMODITY		
AA5-002	TERRAIN/DUTY: 100% (ALL) OF THE TIME, IN TRANSIT, IS SPENT ON PAVED ROADS		
AB1-008	MAXIMUM 8% EXPECTED GRADE		
AB5-001	SMOOTH CONCRETE OR ASPHALT PAVEMENT - MOST SEVERE IN-TRANSIT (BETWEEN SITES) ROAD SURFACE		
995-091	MEDIUM TRUCK WARRANTY		
A66-99D	EXPECTED FRONT AXLE(S) LOAD : 12000.0 lbs		
A68-99D	EXPECTED REAR DRIVE AXLE(S) LOAD : 23000.0 lbs		
A63-99D	EXPECTED GROSS VEHICLE WEIGHT CAPACITY : 35000.0 lbs		
N	A70-99D	EXPECTED GROSS COMBINATION WEIGHT : 0.0 lbs	

Prepared for:
 Everett Glenn
 City of Enid
 401 West Owen K Garriott
 Enid, OK 73702
 Phone: 580-348-0528

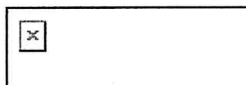

Prepared by:
 Michael McCarthy
 HOUSTON FREIGHTLINER,
 WESTERN STAR
 9550 NORTH LOOP EAST
 HOUSTON, TX 77029
 Phone: 713-580-8122
 E-Mail:
 mmccarthy@strhouston.com

Data Code	Description	Weight Front	Weight Rear
Truck Service			
AA3-003	TANK BODY		
A88-99D	EXPECTED TRUCK BODY LENGTH : 0.0 ft		
AF3-1J8	BERGKAMP INC.		
AF7-99D	EXPECTED BODY/PAYLOAD CG HEIGHT ABOVE FRAME "XX" INCHES : 32.0 in		
Engine			
101-21T	CUM B6.7 240 HP @ 2400 RPM, 2600 GOV, 560 LB/FT @ 1600 RPM		
Electronic Parameters			
79A-075	75 MPH ROAD SPEED LIMIT		
79B-000	CRUISE CONTROL SPEED LIMIT SAME AS ROAD SPEED LIMIT		
* 79K-030	PTO MODE ENGINE RPM LIMIT - 2600 RPM		
79M-001	PTO MODE BRAKE OVERRIDE - SERVICE BRAKE APPLIED		
79P-002	PTO RPM WITH CRUISE SET SWITCH - 700 RPM		
79Q-003	PTO RPM WITH CRUISE RESUME SWITCH - 800 RPM		
79S-001	PTO MODE CANCEL VEHICLE SPEED - 5 MPH		
79U-007	PTO GOVERNOR RAMP RATE - 250 RPM PER SECOND		
80G-002	PTO MINIMUM RPM - 700		
80J-002	REGEN INHIBIT SPEED THRESHOLD - 5 MPH		
Engine Equipment			
99C-017	2016 ONBOARD DIAGNOSTICS/2010 EPA/CARB/FINAL GHG17 CONFIGURATION		
99D-010	NO 2008 CARB EMISSION CERTIFICATION		
13E-001	STANDARD OIL PAN		
105-001	ENGINE MOUNTED OIL CHECK AND FILL		
133-004	ONE PIECE VALVE COVER		
014-099	SIDE OF HOOD AIR INTAKE WITH FIREWALL MOUNTED DONALDSON AIR CLEANER		
124-1D7	DR 12V 160 AMP 28-SI QUADRAMOUNT PAD ALTERNATOR WITH REMOTE BATTERY VOLT SENSE		
292-1D8	(2) ALLIANCE MODEL 1131, GROUP 31, 12 VOLT MAINTENANCE FREE 1900 CCA THREADED STUD BATTERIES, NON FCCC ONLY		
290-017	BATTERY BOX FRAME MOUNTED		

Prepared for:
 Everett Glenn
 City of Enid
 401 West Owen K Garriott
 Enid, OK 73702
 Phone: 580-348-0528

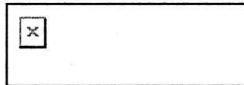

Prepared by:
 Michael McCarthy
 HOUSTON FREIGHTLINER,
 WESTERN STAR
 9550 NORTH LOOP EAST
 HOUSTON, TX 77029
 Phone: 713-580-8122
 E-Mail:
 mmccarthy@strhouston.com

Data Code	Description	Weight Front	Weight Rear
281-001	STANDARD BATTERY JUMPERS		
282-001	SINGLE BATTERY BOX FRAME MOUNTED LH SIDE UNDER CAB		
291-017	WIRE GROUND RETURN FOR BATTERY CABLES WITH ADDITIONAL FRAME GROUND RETURN		
289-001	NON-POLISHED BATTERY BOX COVER		
87P-998	NO CAB AUXILIARY POWER WIRING		
293-058	POSITIVE LOAD DISCONNECT WITH CAB MOUNTED CONTROL SWITCH MOUNTED OUTBOARD DRIVER SEAT	8	
107-032	CUMMINS TURBOCHARGED 18.7 CFM AIR COMPRESSOR WITH INTERNAL SAFETY VALVE		
108-002	STANDARD MECHANICAL AIR COMPRESSOR GOVERNOR		
131-013	AIR COMPRESSOR DISCHARGE LINE		
152-041	ELECTRONIC ENGINE INTEGRAL SHUTDOWN PROTECTION SYSTEM		
016-1C2	RH OUTBOARD UNDER STEP MOUNTED HORIZONTAL AFTERTREATMENT SYSTEM ASSEMBLY WITH RH B-PILLAR MOUNTED VERTICAL TAILPIPE	30	25
28F-002	ENGINE AFTERTREATMENT DEVICE, AUTOMATIC OVER THE ROAD REGENERATION AND DASH MOUNTED REGENERATION REQUEST SWITCH		
239-020	10 FOOT 00 INCH (120 INCH+0/-5.9 INCH) EXHAUST SYSTEM HEIGHT		
237-1CR	RH CURVED VERTICAL TAILPIPE B-PILLAR MOUNTED ROUTED FROM STEP		
23U-001	6 GALLON DIESEL EXHAUST FLUID TANK		
30N-003	100 PERCENT DIESEL EXHAUST FLUID FILL		
43X-002	LH MEDIUM DUTY STANDARD DIESEL EXHAUST FLUID TANK LOCATION		
23Y-001	STANDARD DIESEL EXHAUST FLUID PUMP MOUNTING		
43Y-001	STANDARD DIESEL EXHAUST FLUID TANK CAP		
242-011	ALUMINUM AFTERTREATMENT DEVICE/MUFFLER/TAILPIPE SHIELD(S)		
N 273-035	HORTON HT650 FRONTAL AIR ON/OFF ENGINE FAN CLUTCH		
276-001	AUTOMATIC FAN CONTROL WITHOUT DASH SWITCH, NON ENGINE MOUNTED		
110-003	CUMMINS SPIN ON FUEL FILTER		

Prepared for:
 Everett Glenn
 City of Enid
 401 West Owen K Garriott
 Enid, OK 73702
 Phone: 580-348-0528

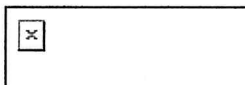

Prepared by:
 Michael McCarthy
 HOUSTON FREIGHTLINER,
 WESTERN STAR
 9550 NORTH LOOP EAST
 HOUSTON, TX 77029
 Phone: 713-580-8122
 E-Mail:
 mmccarthy@strhouston.com

	Data Code	Description	Weight Front	Weight Rear
	118-001	FULL FLOW OIL FILTER		
N	266-078	950 SQUARE INCH ALUMINUM RADIATOR	50	
	103-036	ANTIFREEZE TO -34F, ETHYLENE GLYCOL PRE-CHARGED SCA HEAVY DUTY COOLANT		
	171-007	GATES BLUE STRIPE COOLANT HOSES OR EQUIVALENT		
	172-001	CONSTANT TENSION HOSE CLAMPS FOR COOLANT HOSES		
	270-016	RADIATOR DRAIN VALVE		
	168-002	LOWER RADIATOR GUARD		
	138-010	PHILLIPS-TEMRO 750 WATT/115 VOLT BLOCK HEATER	4	
	140-053	BLACK PLASTIC ENGINE HEATER RECEPTACLE MOUNTED UNDER LH DOOR		
	134-001	ALUMINUM FLYWHEEL HOUSING		
	132-004	ELECTRIC GRID AIR INTAKE WARMER		
	155-058	DELCO 12V 38MT HD STARTER WITH INTEGRATED MAGNETIC SWITCH		
Transmission				
	342-584	ALLISON 3500 RDS AUTOMATIC TRANSMISSION WITH PTO PROVISION	200	60
Transmission Equipment				
*	343-339	ALLISON VOCATIONAL PACKAGE 223 - AVAILABLE ON 3000/4000 PRODUCT FAMILIES WITH VOCATIONAL MODELS RDS, HS, MH AND TRV BODY BUILDER NEEDS OUTPUT SHAFT SPEED OF 5000 RPM, REF VIN GS9527		
	84B-012	ALLISON VOCATIONAL RATING FOR ON/OFF HIGHWAY APPLICATIONS AVAILABLE WITH ALL PRODUCT FAMILIES		
N	84C-023	PRIMARY MODE GEARS, LOWEST GEAR 1, START GEAR 1, HIGHEST GEAR 6, AVAILABLE FOR 3000/4000 PRODUCT FAMILIES ONLY		
	84D-022	SECONDARY MODE GEARS, LOWEST GEAR 1, START GEAR 1, HIGHEST GEAR 5, AVAILABLE FOR 3000/4000 PRODUCT FAMILIES ONLY		
	84E-000	PRIMARY SHIFT SCHEDULE RECOMMENDED BY DTNA AND ALLISON, THIS DEFINED BY ENGINE AND VOCATIONAL USAGE		
	84F-000	SECONDARY SHIFT SCHEDULE RECOMMENDED BY DTNA AND ALLISON, THIS DEFINED BY ENGINE AND VOCATIONAL USAGE		

Prepared for:
 Everett Glenn
 City of Enid
 401 West Owen K Garriott
 Enid, OK 73702
 Phone: 580-348-0528

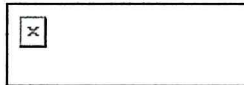

Prepared by:
 Michael McCarthy
 HOUSTON FREIGHTLINER,
 WESTERN STAR
 9550 NORTH LOOP EAST
 HOUSTON, TX 77029
 Phone: 713-580-8122
 E-Mail:
 mmccarthy@strhouston.com

Data Code	Description	Weight Front	Weight Rear
84G-000	PRIMARY SHIFT SPEED RECOMMENDED BY DTNA AND ALLISON, THIS DEFINED BY ENGINE AND VOCATIONAL USAGE		
84H-000	SECONDARY SHIFT SPEED RECOMMENDED BY DTNA AND ALLISON, THIS DEFINED BY ENGINE AND VOCATIONAL USAGE		
84L-000	LOAD BASED SHIFT SCHEDULE AND VEHICLE ACCELERATION CONTROL RECOMMENDED BY DTNA AND ALLISON, THIS DEFINED VOCATIONAL USAGE		
84N-000	NEUTRAL AT STOP - DISABLED, FUELSENSE - DISABLED		
84U-000	DRIVER SWITCH INPUT - DEFAULT - NO SWITCHES		
353-022	VEHICLE INTERFACE WIRING CONNECTOR WITHOUT BLUNT CUTS, AT BACK OF CAB		
34C-002	ELECTRONIC TRANSMISSION CUSTOMER ACCESS CONNECTOR MOUNTED BACK OF CAB		
362-035	CUSTOMER INSTALLED CHELSEA 277 SERIES PTO		
363-002	PTO MOUNTING, RH SIDE OF MAIN TRANSMISSION		
341-018	MAGNETIC PLUGS, ENGINE DRAIN, TRANSMISSION DRAIN, AXLE(S) FILL AND DRAIN		
345-003	PUSH BUTTON ELECTRONIC SHIFT CONTROL, DASH MOUNTED		
97G-004	TRANSMISSION PROGNOSTICS - ENABLED 2013		
370-015	WATER TO OIL TRANSMISSION COOLER, IN RADIATOR END TANK		
346-003	TRANSMISSION OIL CHECK AND FILL WITH ELECTRONIC OIL LEVEL CHECK		
35T-001	SYNTHETIC TRANSMISSION FLUID (TES-295 COMPLIANT)		

Front Axle and Equipment

400-1A6	DETROIT DA-F-12.0-3 12,000# FF1 71.5 KPI/3.74 DROP SINGLE FRONT AXLE
402-020	MERITOR 15X4 Q+ CAM FRONT BRAKES
403-002	NON-ASBESTOS FRONT BRAKE LINING
419-023	CONMET CAST IRON FRONT BRAKE DRUMS
409-006	FRONT OIL SEALS
408-001	VENTED FRONT HUB CAPS WITH WINDOW, CENTER AND SIDE PLUGS - OIL

Prepared for:
 Everett Glenn
 City of Enid
 401 West Owen K Garriott
 Enid, OK 73702
 Phone: 580-348-0528

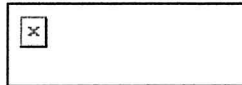

Prepared by:
 Michael McCarthy
 HOUSTON FREIGHTLINER,
 WESTERN STAR
 9550 NORTH LOOP EAST
 HOUSTON, TX 77029
 Phone: 713-580-8122
 E-Mail:
 mmccarthy@strhouston.com

Data Code	Description	Weight Front	Weight Rear
416-022	STANDARD SPINDLE NUTS FOR ALL AXLES		
405-002	MERITOR AUTOMATIC FRONT SLACK ADJUSTERS		
536-050	TRW THP-60 POWER STEERING		
539-003	POWER STEERING PUMP		
534-015	2 QUART SEE THROUGH POWER STEERING RESERVOIR		
40T-002	SYNTHETIC 75W-90 FRONT AXLE LUBE		
Front Suspension			
620-1F0	12,000# DUAL TAPERLEAF FRONT SUSPENSION	42	
619-005	MAINTENANCE FREE RUBBER BUSHINGS - FRONT SUSPENSION		
410-001	FRONT SHOCK ABSORBERS		
Rear Axle and Equipment			
420-051	RS-23-160 23,000# R-SERIES SINGLE REAR AXLE		180
421-538	5.38 REAR AXLE RATIO		
424-001	IRON REAR AXLE CARRIER WITH STANDARD AXLE HOUSING		
386-073	MXL 17T MERITOR EXTENDED LUBE MAIN DRIVELINE WITH HALF ROUND YOKES		
452-001	DRIVER CONTROLLED TRACTION DIFFERENTIAL - SINGLE REAR AXLE		20
878-018	(1) DRIVER CONTROLLED DIFFERENTIAL LOCK REAR VALVE FOR SINGLE DRIVE AXLE		
87B-004	BLINKING LAMP WITH EACH MODE SWITCH, DIFFERENTIAL UNLOCK WITH IGNITION OFF, ACTIVE <5 MPH		
423-019	MERITOR 16.5X8.62 Q+ CAST SPIDER CAM REAR BRAKES, DOUBLE ANCHOR, FABRICATED SHOES		
433-002	NON-ASBESTOS REAR BRAKE LINING		
434-011	BRAKE CAMS AND CHAMBERS ON FORWARD SIDE OF DRIVE AXLE(S)		
451-023	CONMET CAST IRON REAR BRAKE DRUMS		
425-002	REAR BRAKE DUST SHIELDS		5
440-006	REAR OIL SEALS		
426-100	WABCO TRISTOP D LONGSTROKE 1-DRIVE AXLE SPRING PARKING CHAMBERS		
428-002	MERITOR AUTOMATIC REAR SLACK ADJUSTERS		

Prepared for:
 Everett Glenn
 City of Enid
 401 West Owen K Garriott
 Enid, OK 73702
 Phone: 580-348-0528

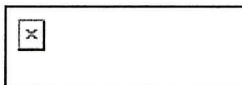

Prepared by:
 Michael McCarthy
 HOUSTON FREIGHTLINER,
 WESTERN STAR
 9550 NORTH LOOP EAST
 HOUSTON, TX 77029
 Phone: 713-580-8122
 E-Mail:
 mmccarthy@strhouston.com

Data Code	Description	Weight Front	Weight Rear
41T-002	SYNTHETIC 75W-90 REAR AXLE LUBE		
Rear Suspension			
622-1MJ	23,000# 52 INCH VARIABLE RATE MULTI-LEAF SPRING REAR SUSPENSION WITH LEAF SPRING HELPER		110
621-001	SPRING SUSPENSION - NO AXLE SPACERS		
431-001	STANDARD AXLE SEATS IN AXLE CLAMP GROUP		
Brake System			
018-002	AIR BRAKE PACKAGE		
490-100	WABCO 4S/4M ABS WITHOUT TRACTION CONTROL		
871-001	REINFORCED NYLON, FABRIC BRAID AND WIRE BRAID CHASSIS AIR LINES		
904-001	FIBER BRAID PARKING BRAKE HOSE		
412-001	STANDARD BRAKE SYSTEM VALVES		
46D-002	STANDARD AIR SYSTEM PRESSURE PROTECTION SYSTEM		
413-002	STD U.S. FRONT BRAKE VALVE		
432-003	RELAY VALVE WITH 5-8 PSI CRACK PRESSURE, NO REAR PROPORTIONING VALVE		
480-009	BW AD-9 BRAKE LINE AIR DRYER WITH HEATER	20	
479-012	AIR DRYER MOUNTED UNDER HOOD		
460-001	STEEL AIR BRAKE RESERVOIRS		
607-001	CLEAR FRAME RAILS FROM BACK OF CAB TO FRONT REAR SUSPENSION BRACKET, BOTH RAILS OUTBOARD		
477-004	PULL CABLES ON ALL AIR RESERVOIR(S)		
Trailer Connections			
335-004	UPGRADED CHASSIS MULTIPLEXING UNIT		
32A-002	UPGRADED BULKHEAD MULTIPLEXING UNIT		
Wheelbase & Frame			
545-487	4875MM (192 INCH) WHEELBASE		
546-101	11/32X3-1/2X10-15/16 INCH STEEL FRAME (8.73MMX277.8MM/0.344X10.94 INCH) 120KSI	120	120
552-149	875MM (34 INCH) REAR FRAME OVERHANG		
55W-003	FRAME OVERHANG RANGE: 31 INCH TO 40 INCH	20	-120
AC8-99D	CALC'D BACK OF CAB TO REAR SUSP C/L (CA) : 126.45 in		

Prepared for:
 Everett Glenn
 City of Enid
 401 West Owen K Garriott
 Enid, OK 73702
 Phone: 580-348-0528

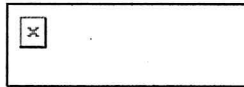

Prepared by:
 Michael McCarthy
 HOUSTON FREIGHTLINER,
 WESTERN STAR
 9550 NORTH LOOP EAST
 HOUSTON, TX 77029
 Phone: 713-580-8122
 E-Mail:
 mmccarthy@strhouston.com

Data Code	Description	Weight Front	Weight Rear
AE8-99D	CALCULATED EFFECTIVE BACK OF CAB TO REAR SUSPENSION C/L (CA) : 123.45 in		
AE4-99D	CALC'D FRAME LENGTH - OVERALL : 255.39		
AM6-99D	CALC'D SPACE AVAILABLE FOR DECKPLATE : 126.45 in		
FSS-0LH	CALCULATED FRAME SPACE LH SIDE : 106.84 in		
FSS-0RH	CALCULATED FRAME SPACE RH SIDE : 106.81 in		
553-001	SQUARE END OF FRAME		
550-001	FRONT CLOSING CROSSMEMBER		
559-001	STANDARD WEIGHT ENGINE CROSSMEMBER		
561-001	STANDARD CROSSMEMBER BACK OF TRANSMISSION		
562-001	STANDARD MIDSHIP #1 CROSSMEMBER(S)		
572-001	STANDARD REARMOST CROSSMEMBER		
565-001	STANDARD SUSPENSION CROSSMEMBER		
Chassis Equipment			
556-1AP	THREE-PIECE 14 INCH PAINTED STEEL BUMPER WITH COLLAPSIBLE ENDS	30	
558-001	FRONT TOW HOOKS - FRAME MOUNTED	15	
574-001	BUMPER MOUNTING FOR SINGLE LICENSE PLATE		
586-024	FENDER AND FRONT OF HOOD MOUNTED FRONT MUDFLAPS		
551-007	GRADE 8 THREADED HEX HEADED FRAME FASTENERS		
Fuel Tanks			
204-215	50 GALLON/189 LITER SHORT RECTANGULAR ALUMINUM FUEL TANK - LH	20	
218-005	RECTANGULAR FUEL TANK(S)		
215-005	PLAIN ALUMINUM/PAINTED STEEL FUEL/HYDRAULIC TANK(S) WITH PAINTED BANDS		
212-007	FUEL TANK(S) FORWARD		
664-001	PLAIN STEP FINISH		
205-001	FUEL TANK CAP(S)		
122-1J2	DETROIT FUEL/WATER SEPARATOR WITH WATER IN FUEL SENSOR AND HAND PRIMER	-5	
216-020	EQUIFLO INBOARD FUEL SYSTEM		

Prepared for:
 Everett Glenn
 City of Enid
 401 West Owen K Garriott
 Enid, OK 73702
 Phone: 580-348-0528

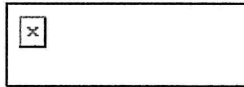

Prepared by:
 Michael McCarthy
 HOUSTON FREIGHTLINER,
 WESTERN STAR
 9550 NORTH LOOP EAST
 HOUSTON, TX 77029
 Phone: 713-580-8122
 E-Mail:
 mmccarthy@strhouston.com

Data Code	Description	Weight Front	Weight Rear
11F-998	NO NATURAL GAS VEHICLE FUEL TANK VENT LINE/STACK		
202-016	HIGH TEMPERATURE REINFORCED NYLON FUEL LINE		
Tires			
093-2C5	HANKOOK AL11 11R22.5 14 PLY RADIAL FRONT TIRES	8	
094-2C6	HANKOOK DL11 11R22.5 14 PLY RADIAL REAR TIRES		60
Hubs			
418-060	CONMET PRESET PLUS PREMIUM IRON FRONT HUBS		
450-060	CONMET PRESET PLUS PREMIUM IRON REAR HUBS		
Wheels			
502-523	MAXION WHEELS 90262 22.5X8.25 10-HUB PILOT 6.19 INSET 5-HAND STEEL DISC FRONT WHEELS	18	
505-523	MAXION WHEELS 90262 22.5X8.25 10-HUB PILOT 5-HAND STEEL DISC REAR WHEELS		36
496-011	FRONT WHEEL MOUNTING NUTS		
497-011	REAR WHEEL MOUNTING NUTS		
Cab Exterior			
829-071	106 INCH BBC FLAT ROOF ALUMINUM CONVENTIONAL CAB		
650-008	AIR CAB MOUNTING		
648-002	NONREMOVABLE BUGSCREEN MOUNTED BEHIND GRILLE		
678-001	LH AND RH GRAB HANDLES		
646-023	HOOD MOUNTED CHROMED PLASTIC GRILLE		
65X-003	CHROME HOOD MOUNTED AIR INTAKE GRILLE		
644-004	FIBERGLASS HOOD		
727-1AH	SINGLE 14 INCH ROUND POLISHED AIR HORN ROOF MOUNTED	4	
726-001	SINGLE ELECTRIC HORN		
728-001	SINGLE HORN SHIELD		
657-001	DOOR LOCKS AND IGNITION SWITCH KEYED THE SAME		
575-001	REAR LICENSE PLATE MOUNT END OF FRAME		

Prepared for:
 Everett Glenn
 City of Enid
 401 West Owen K Garriott
 Enid, OK 73702
 Phone: 580-348-0528

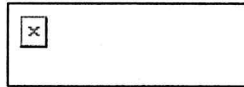

Prepared by:
 Michael McCarthy
 HOUSTON FREIGHTLINER,
 WESTERN STAR
 9550 NORTH LOOP EAST
 HOUSTON, TX 77029
 Phone: 713-580-8122
 E-Mail:
 mmccarthy@strhouston.com

Data Code	Description	Weight Front	Weight Rear
312-038	INTEGRAL HEADLIGHT/MARKER ASSEMBLY WITH CHROME BEZEL		
302-047	LED AERODYNAMIC MARKER LIGHTS		
294-090	OMIT STOP/TAIL/BACKUP LIGHTS AND PROVIDE WIRING FOR COMBINED STOP/TURN LIGHTS TO FOUR FEET BEYOND END OF FRAME		-5
300-015	STANDARD FRONT TURN SIGNAL LAMPS		
744-1BH	DUAL WEST COAST MOLDED-IN COLOR MIRRORS		
797-001	DOOR MOUNTED MIRRORS		
796-001	102 INCH EQUIPMENT WIDTH		
743-1AP	LH AND RH 8 INCH MOLDED-IN COLOR CONVEX MIRRORS MOUNTED UNDER PRIMARY MIRRORS		
74A-001	RH DOWN VIEW MIRROR		
729-001	STANDARD SIDE/REAR REFLECTORS		
768-043	63X14 INCH TINTED REAR WINDOW		
661-003	TINTED DOOR GLASS LH AND RH WITH TINTED NON-OPERATING WING WINDOWS		
654-027	RH AND LH ELECTRIC POWERED WINDOWS, PASSENGER SWITCHES ON DOOR(S)	4	
663-013	TINTED WINDSHIELD		
659-019	2 GALLON WINDSHIELD WASHER RESERVOIR WITHOUT FLUID LEVEL INDICATOR, FRAME MOUNTED		

Cab Interior

707-1AK	OPAL GRAY VINYL INTERIOR		
706-013	MOLDED PLASTIC DOOR PANEL		
708-013	MOLDED PLASTIC DOOR PANEL		
772-006	BLACK MATS WITH SINGLE INSULATION		
691-008	FORWARD ROOF MOUNTED CONSOLE WITH UPPER STORAGE COMPARTMENTS WITHOUT NETTING		
694-010	IN DASH STORAGE BIN		
742-007	(2) CUP HOLDERS LH AND RH DASH		
680-006	GRAY/CHARCOAL FLAT DASH		
720-002	2-1/2 LB. FIRE EXTINGUISHER	5	
700-002	HEATER, DEFROSTER AND AIR CONDITIONER		
701-001	STANDARD HVAC DUCTING		
703-005	MAIN HVAC CONTROLS WITH RECIRCULATION SWITCH		

Prepared for:
 Everett Glenn
 City of Enid
 401 West Owen K Garriott
 Enid, OK 73702
 Phone: 580-348-0528

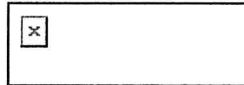

Prepared by:
 Michael McCarthy
 HOUSTON FREIGHTLINER,
 WESTERN STAR
 9550 NORTH LOOP EAST
 HOUSTON, TX 77029
 Phone: 713-580-8122
 E-Mail:
 mmccarthy@strhouston.com

Data Code	Description	Weight Front	Weight Rear
170-015	STANDARD HEATER PLUMBING		
130-033	DENSO HEAVY DUTY AIR CONDITIONER COMPRESSOR		
702-002	BINARY CONTROL, R-134A		
739-033	STANDARD INSULATION		
285-013	SOLID-STATE CIRCUIT PROTECTION AND FUSES		
280-007	12V NEGATIVE GROUND ELECTRICAL SYSTEM		
324-014	DOME LIGHT WITH 3-WAY SWITCH ACTIVATED BY LH AND RH DOORS		
655-005	LH AND RH ELECTRIC DOOR LOCKS		
284-023	(1) 12 VOLT POWER SUPPLY IN DASH		
722-028	TRIANGULAR REFLECTORS KIT WITHOUT FLARES SHIPPED LOOSE IN CAB	10	
756-1J3	BASIC HIGH BACK AIR SUSPENSION DRIVER SEAT WITH MECHANICAL LUMBAR AND INTEGRATED CUSHION EXTENSION	30	
760-1J3	BASIC HIGH BACK AIR SUSPENSION PASSENGER SEAT WITH MECHANICAL LUMBAR AND INTEGRATED CUSHION EXTENSION	25	10
711-004	LH AND RH INTEGRAL DOOR PANEL ARMRESTS		
758-036	VINYL WITH VINYL INSERT DRIVER SEAT		
761-036	VINYL WITH VINYL INSERT PASSENGER SEAT		
763-102	HIGH VISIBILITY ORANGE SEAT BELTS		
532-002	ADJUSTABLE TILT AND TELESCOPING STEERING COLUMN	10	
540-015	4-SPOKE 18 INCH (450MM) STEERING WHEEL		
765-002	DRIVER AND PASSENGER INTERIOR SUN VISORS		

Instruments & Controls

732-004	GRAY DRIVER INSTRUMENT PANEL		
734-004	GRAY CENTER INSTRUMENT PANEL		
870-001	BLACK GAUGE BEZELS		
486-001	LOW AIR PRESSURE INDICATOR LIGHT AND AUDIBLE ALARM		
840-002	2 INCH PRIMARY AND SECONDARY AIR PRESSURE GAUGES		
198-025	INTAKE MOUNTED AIR RESTRICTION INDICATOR WITHOUT GRADUATIONS		
721-001	97 DB BACKUP ALARM		3

Prepared for:
 Everett Glenn
 City of Enid
 401 West Owen K Garriott
 Enid, OK 73702
 Phone: 580-348-0528

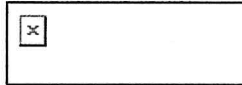

Prepared by:
 Michael McCarthy
 HOUSTON FREIGHTLINER,
 WESTERN STAR
 9550 NORTH LOOP EAST
 HOUSTON, TX 77029
 Phone: 713-580-8122
 E-Mail:
 mmccarthy@strhouston.com

Data Code	Description	Weight Front	Weight Rear
149-013	ELECTRONIC CRUISE CONTROL WITH SWITCHES IN LH SWITCH PANEL		
156-007	KEY OPERATED IGNITION SWITCH AND INTEGRAL START POSITION; 4 POSITION OFF/RUN/START/ACCESSORY		
811-042	ICU3S, 132X48 DISPLAY WITH DIAGNOSTICS, 28 LED WARNING LAMPS AND DATA LINKED		
160-038	HEAVY DUTY ONBOARD DIAGNOSTICS INTERFACE CONNECTOR LOCATED BELOW LH DASH		
844-001	2 INCH ELECTRIC FUEL GAUGE		
148-003	PROGRAMMABLE RPM CONTROL - ELECTRONIC ENGINE		
856-001	ELECTRICAL ENGINE COOLANT TEMPERATURE GAUGE		
864-005	TRANSMISSION OIL TEMPERATURE INDICATOR LIGHT		
830-017	ENGINE AND TRIP HOUR METERS INTEGRAL WITHIN DRIVER DISPLAY		
438-001	STEMCO MECHANICAL HUBODOMETER WITH TENTHS LEFT SIDE SINGLE OR FORWARD REAR DRIVE AXLE		2
372-035	(1) DASH MOUNTED PTO SWITCH WITH INDICATOR LAMP	5	
852-002	ELECTRIC ENGINE OIL PRESSURE GAUGE		
746-115	AM/FM/WB WORLD TUNER RADIO WITH BLUETOOTH AND USB AND AUXILIARY INPUTS, J1939	10	
747-001	DASH MOUNTED RADIO		
750-002	(2) RADIO SPEAKERS IN CAB		
753-001	AM/FM ANTENNA MOUNTED ON FORWARD LH ROOF		
810-027	ELECTRONIC MPH SPEEDOMETER WITH SECONDARY KPH SCALE, WITHOUT ODOMETER		
817-001	STANDARD VEHICLE SPEED SENSOR		
812-001	ELECTRONIC 3000 RPM TACHOMETER		
162-011	IDLE LIMITER, ELECTRONIC ENGINE		
329-010	TWO ON/OFF ROCKER SWITCHES IN THE DASH WITH INDICATOR LIGHTS AND WIRE ROUTED TO CHASSIS AT BACK OF CAB, LABEL OPT		
81Y-001	PRE-TRIP LAMP INSPECTION, ALL OUTPUTS FLASH, WITH SMART SWITCH		

Prepared for:
 Everett Glenn
 City of Enid
 401 West Owen K Garriott
 Enid, OK 73702
 Phone: 580-348-0528

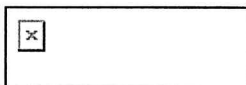

Prepared by:
 Michael McCarthy
 HOUSTON FREIGHTLINER,
 WESTERN STAR
 9550 NORTH LOOP EAST
 HOUSTON, TX 77029
 Phone: 713-580-8122
 E-Mail:
 mmccarthy@strhouston.com

Data Code	Description	Weight Front	Weight Rear
836-015	DIGITAL VOLTAGE DISPLAY INTEGRAL WITH DRIVER DISPLAY		
660-008	SINGLE ELECTRIC WINDSHIELD WIPER MOTOR WITH DELAY		
304-001	MARKER LIGHT SWITCH INTEGRAL WITH HEADLIGHT SWITCH		
882-009	ONE VALVE PARKING BRAKE SYSTEM WITH WARNING INDICATOR		
299-013	SELF CANCELING TURN SIGNAL SWITCH WITH DIMMER, WASHER/WIPER AND HAZARD IN HANDLE		
298-039	INTEGRAL ELECTRONIC TURN SIGNAL FLASHER WITH HAZARD LAMPS OVERRIDING STOP LAMPS		

Design

065-000 PAINT: ONE SOLID COLOR

Color

980-5F6 CAB COLOR A: L0006EB WHITE ELITE BC
 986-020 BLACK, HIGH SOLIDS POLYURETHANE CHASSIS PAINT
 962-972 POWDER WHITE (N0006EA) FRONT WHEELS/RIMS (PKWHT21, TKWHT21, W, TW)
 966-972 POWDER WHITE (N0006EA) REAR WHEELS/RIMS (PKWHT21, TKWHT21, W, TW)
 964-6Z7 BUMPER PAINT: FP24812 ARGENT SILVER DUPONT FLEX
 963-003 STANDARD E COAT/UNDERCOATING

Certification / Compliance

996-001 U.S. FMVSS CERTIFICATION, EXCEPT SALES CABS AND GLIDER KITS

Secondary Factory Options

998-001 CORPORATE PDI CENTER IN-SERVICE ONLY

TOTAL VEHICLE SUMMARY

Weight Summary

Weight Front	Weight Rear	Total Weight
--------------	-------------	--------------

Prepared for:
Everett Glenn
City of Enid
401 West Owen K Garriott
Enid, OK 73702
Phone: 580-348-0528

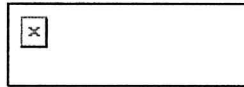

Prepared by:
Michael McCarthy
HOUSTON FREIGHTLINER,
WESTERN STAR
9550 NORTH LOOP EAST
HOUSTON, TX 77029
Phone: 713-580-8122
E-Mail:
mmccarthy@strhouston.com

Factory Weight ⁺	6442 lbs	4009 lbs	10451 lbs
<hr/>			
Total Weight ⁺	6442 lbs	4009 lbs	10451 lbs

(+) Weights shown are estimates only.
If weight is critical, contact Customer Application Engineering.

Prepared for:
 Everett Glenn
 City of Enid
 401 West Owen K Garriott
 Enid, OK 73702
 Phone: 580-348-0528

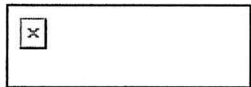

Prepared by:
 Michael McCarthy
 HOUSTON FREIGHTLINER,
 WESTERN STAR
 9550 NORTH LOOP EAST
 HOUSTON, TX 77029
 Phone: 713-580-8122
 E-Mail:
 mmccarthy@strhouston.com

D I M E N S I O N S

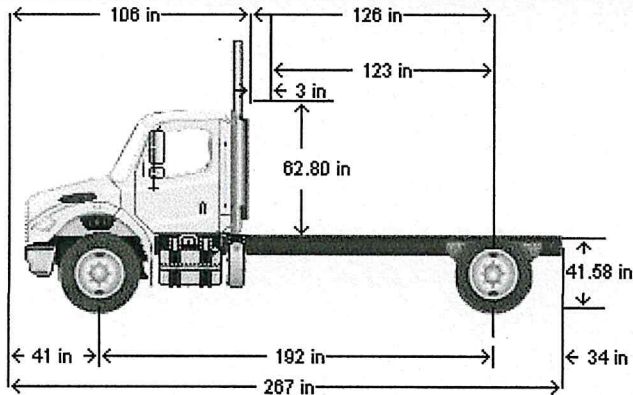

VEHICLE SPECIFICATIONS SUMMARY - DIMENSIONS

Model	M2106
Wheelbase (545)	4875MM (192 INCH) WHEELBASE
Rear Frame Overhang (552).....	875MM (34 INCH) REAR FRAME OVERHANG
Fifth Wheel (578)	NO FIFTH WHEEL
Mounting Location (577)	NO FIFTH WHEEL LOCATION
Maximum Forward Position (in).....	0
Maximum Rearward Position (in)	0
Amount of Slide Travel (in).....	0
Slide Increment (in).....	0
Desired Slide Position (in).....	0.0
Cab Size (829).....	106 INCH BBC FLAT ROOF ALUMINUM CONVENTIONAL CAB
Sleeper (682).....	NO SLEEPER BOX/SLEEPER CAB
Exhaust System (016).....	RH OUTBOARD UNDER STEP MOUNTED HORIZONTAL AFTERTREATMENT SYSTEM ASSEMBLY WITH RH B-PILLAR MOUNTED VERTICAL TAILPIPE

TABLE SUMMARY - DIMENSIONS

Prepared for:
 Everett Glenn
 City of Enid
 401 West Owen K Garriott
 Enid, OK 73702
 Phone: 580-348-0528

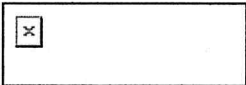

Prepared by:
 Michael McCarthy
 HOUSTON FREIGHTLINER,
 WESTERN STAR
 9550 NORTH LOOP EAST
 HOUSTON, TX 77029
 Phone: 713-580-8122
 E-Mail:
 mmccarthy@strhouston.com

Dimensions	Inches
Bumper to Back of Cab (BBC)	106.3
Bumper to Centerline of Front Axle (BA)	40.7
Min. Cab to Body Clearance (CB)	3.0
Back of Cab to Centerline of Rear Axle(s) (CA)	126.4
Effective Back of Cab to Centerline of Rear Axle(s) (Effective CA)	123.4
Back of Cab Protrusions (Exhaust/Intake) (CP)	0.0
Back of Cab Protrusions (Side Extenders/Trim Tab) (CP)	0.0
Back of Cab Protrusions (CNG Tank)	0.0
Back of Cab Clearance (CL)	3.0
Back of Cab to End of Frame	160.4
Cab Height (CH)	62.8
Wheelbase (WB)	192.0
Frame Overhang (OH)	34.0
Overall Length (OAL)	266.7
Rear Axle Spacing	0.0
Unladen Frame Height at Centerline of Rear Axle	41.6

Performance calculations are estimates only. If performance calculations are critical, please contact Customer Application Engineering.



Patented Swing Auger System

Great for shoulder and large utility repairs and fixing multiple potholes from one location.

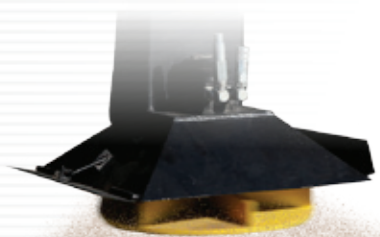

Sand Spreader

Evenly disperses sand to improve traction on roads during winter months.

Optional Equipment Meets Your Specific Patching Needs

For Bergkamp's Flameless Pothole Patcher

Accomplished, yet flexible. Bergkamp's all-in-one Flameless Pothole Patcher, the pioneer of the first proven flameless electric-heat system more than 10 years ago, comes standard with a variety of features that deliver permanent patches. But, everyone has their own preferences, so we provide multiple options that you can use with our patchers and can customize special requests specific to your needs.

No matter how you choose to equip your patcher, you will safely be producing permanent pothole repairs right away, leaving previously angry residents with a smile.

BERGKAMP
PAVEMENT PRESERVATION SOLUTIONS

Fix More Potholes, Faster

Patented Swing Auger System Simplifies Pothole Patching

Our patented Swing Auger System significantly increases the flexibility of your Bergkamp Flameless Pothole Patcher. This unique optional replacement for the standard material chute allows for precise and continual placement of asphalt so small crews can easily fix many potholes from one truck location without difficult hand work.

More Flexibility In Asphalt Delivery

- Wide 8.7-foot (2.7-meter) swing ranges from the driver side wheel track past the passenger side wheel track
- Ideal for easy and efficient shoulder, curb, gutter and large utility repairs
- Easily accessible at the back of the machine to keep the operator away from traffic

On trucks equipped with an automatic transmission, the Swing Auger System can be locked into a side auger position to permit continual placement of material outside the passenger side wheel track. Already have a flameless pothole patcher? Retrofit kits are available for current owners.

Swing Auger System Operating Parameters

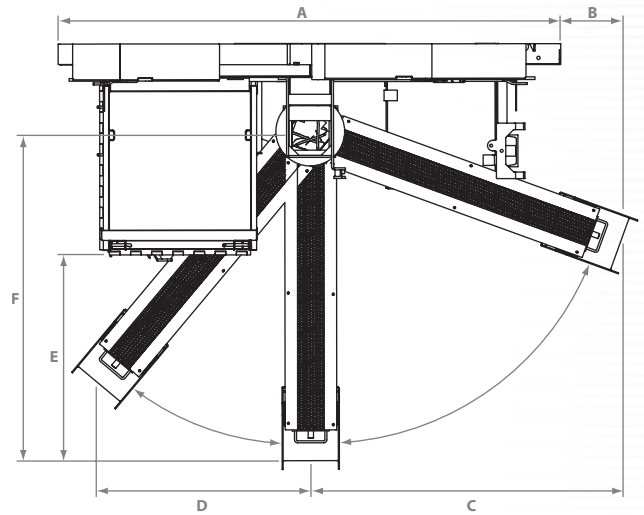

PLATE COMPACTOR		
A	96 in.	244 cm
B	12 in.	30.5 cm
C	62 in.	158 cm
D	42 in.	107 cm
E	38 in.	97 cm
F	60 in.	152 cm

ROLLER PLATFORM		
A	96 in.	244 cm
B	7 in.	18 cm
C	57 in.	145 cm
D	42 in.	107 cm
E	38 in.	97 cm
F	60 in.	152 cm



Expand Your Winter Capabilities

Sand Spreader Attachment Maximizes Truck Utilization

One truck, multiple uses. Our Sand Spreader attachment allows you to productively employ the Bergkamp Flameless Pothole Patcher in winter months when patching is not always ideal. Used in place of the standard material chute or Swing Auger System, it applies an even coat of sand to up to 50 miles (80.5 kilometers) of roadway to create traction before and after snow fall and freezing precipitation.

Easy To Attach & Operate: Since the Sand Spreader runs off the same hydraulic system as the Flameless Pothole Patcher, switching between spreading asphalt and sand is quick and easy. The unit's selector valve shuts off patching mode to prepare for spreading sand. Quick disconnects allow you to easily disconnect the hydraulic breaker hoses and connect the Sand Spreader spinner. Once attached, easy-to-use in-cab controls let you regulate how much sand is being laid down and adjust spinner speed to change the width of the sand coverage from 5 to 34 feet (1.5 to 10.4 meters).



Sand spreader is not intended for use with salt

Convenient Benefits:

- To stretch your budget, it can be used exclusively or in conjunction with salt trucks
- Ready in less than one hour so areas that don't use salt can quickly handle surprise snowfall and freezing precipitation
- Easily stored and protected when not being used
- Non-corrosive sand is more vehicle friendly compared to salt

Single-Lane Operating Parameters

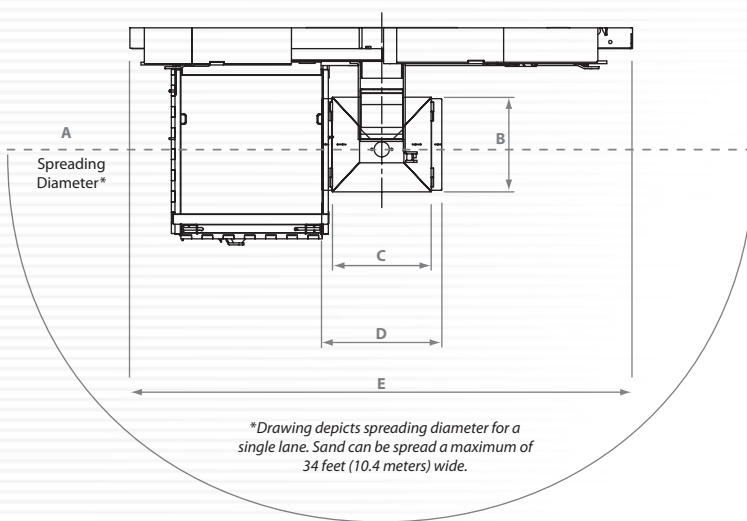

SAND SPREADER		
A	168 in.	427 cm
B	20 in.	51 cm
C	21 in.	54 cm
D	26 in.	65 cm
E	96 in.	244 cm

Customizable To Fit Your Needs

In addition to the Swing Auger System and Sand Spreader, Bergkamp offers these options for the flameless pothole patcher:

- InPave™ Monitoring and Reporting System
- Secondary auger motor
- LED lights
- Upgraded arrow boards
- Single-drum vibratory roller
- Traffic cone holders
- Shovel and asphalt lute holder
- Propane hand torch
- Front cleaning fluid hand spray wand
- Various sizes of pavement breaker hammers and attachments
- Others available upon request

BERGKAMP

PAVEMENT PRESERVATION SOLUTIONS

Providing Pavement Preservation Solutions Worldwide

Bergkamp Inc. has been an expert in pavement maintenance equipment for more than 35 years, and works with customers throughout the world. The company's success continues to grow through hands-on knowledge of the industry and its products, and the company's dedication to customer support.

Bergkamp is the only manufacturer to produce a full-size continuous slurry seal and micro surfacing paver. It also designs and manufactures a full line of truck- and trailer-mounted slurry seal and micro surfacing pavers and equipment, along with truck-mounted flameless pothole patchers.

Contact Bergkamp today to find cost-effective solutions for extending the life of highways, roads and parking lots.

www.bergkampinc.com

sales@bergkampinc.com

service@bergkampinc.com

Bergkamp Inc.

3040 Emulsion Drive • Salina, KS 67401-8966 USA
Phone: (785) 825-1375 • Fax: (785) 825-4269

Proud Member Of:



M310 Paver



M2 Series Pavers



M216 Trailer-Mounted Paver



Spreader Boxes



M1 Series Continuous Pavers



Mobile Support Units



A3000 Paver



Flameless Pothole Patcher

City Commission Meeting

7.3.

Meeting Date: 06/19/2018

Submitted By: Kelley Munkres, Administrative Assistant

SUBJECT:

AWARD PURCHASE OF ONE JOHN BEAN SJ704020 JETTER FOR THE PUBLIC WORKS DIVISION, FROM FRONTIER EQUIPMENT, YUKON, OKLAHOMA, IN THE AMOUNT OF \$54,434.22.

BACKGROUND:

During the budget process, the need to add a jetter was identified. The Oklahoma State Purchasing Contract SW193 with Frontier Equipment provided a quote of \$54,434.22.

This jetter is appropriate for use by Public Works and the state price is competitive. Utilizing the state list alleviates the need for the City to pursue its own competitive bidding.

RECOMMENDATION:

Award purchase to Frontier Equipment in the amount of \$54,434.22.

PRESENTER:

Everett Glenn, Public Works Director

Fiscal Impact

Budgeted Y/N: Y
Amount: \$54,434.22
Funding Source:
43-435-4406

Attachments

Frontier Contact
Quote
SW193 Addendum
SW193 Notice of Award
Jetter

Company Name	Frontier Equipment Sales, L.L.C.
Doing Business as (if applicable)	
Contact Person for Solicitation Response	Clark Kerr
Phone	405-354-2611
Email	frontiercdk@gmail.com
Address For Purchase Orders-Number & Street-Post Office Box (some companies have ordering addresses that are are different than the payment address)	P.O. Box 850114
City, State, Zip	Yukon, OK 73085
Contact Person for Contract/Ordering/Price Information/Equipment Additions/Changes/Discontinuations	Clark Kerr
Phone	405-354-2611
Fax	405-354-2992
Email	frontiercdk@gmail.com
Secondary Contact for Contract/Ordering	N/A
Phone	N/A
Fax	N/A
Email	N/A
Address For Payment-Number & Street-Post Office Box (some companies have a different Payment/remittance address than the ordering address)	P.O. Box 850114
City, State, Zip	Yukon, OK 73085
Contact Person/Department for payment	Haley Hill
Phone	405-354-2611
Fax	405-354-2992
Email	frontierrecept@gmail.com
Counties You can provide products/warranty service/repair parts to	<input checked="" type="checkbox"/> All counties in Oklahoma OR just these counties: _____
	(include any special conditions, such as territory or district maps on a separate sheet)
Continued-counties	OR all BUT these counties:
Trade-ins	<input checked="" type="checkbox"/> Available <input type="checkbox"/> Not Available (Include any special conditions on a separate sheet)
Payment Discount (i.e. 15 days)	Net N/A days
Supplier will be responsible for notifying the contracting officer when the contact information changes.	Notes: (Special ordering instructions-please attach any special instructions on a separate sheet)

Physical Address For Repair:

DCS/PURCHASING

4123 North Banner Road

SOLICITATION PACKAGE - PAGE 17

E1 Reno, OK 73036

TECHNICAL REQUIREMENTS

8. Our units can be purchased as one piece or the customer can provide their own chassis (new or used.) This is the customer's choice.

Vac-Con
969 Hall Park Dr.
Green Cove Springs, FL 32043
Phone - 888-491-5762

John Bean Jetters
101 Durand Rd.
Lagrange, GA 30241
Phone - 800-241-2308

US Jetting
850 McFarland Rd.
Alpharetta, GA. 30004
Phone - 800 - 538 - 8464

If the chassis is provided by the manufacturer (or Frontier Equipment Sales, L.L.C.) it will be new and there will be no discount offered on the chassis, just the body. If the chassis is provided by the manufacturer, the customer is allowed their choice of reduced chassis options on an in-stock chassis or choice of full selection of chassis options on an ordered chassis (ordered chassis may affect delivery time.) We receive no discount on these chassis. What they cost us is what they cost the customer.

In some cases, there will be a mounting charge for customer supplied chassis. The customer will be responsible to make sure their chassis will meet the manufacturer's requirement. The customer will be responsible for delivery of the chassis to the manufacturer. We will provide delivery from the manufacturer to the customer.

9. 35% restocking fee plus shipping on parts (within 30 days of order.) If Frontier Equipment Sales makes a mistake when ordering the part, there will be no charge for returns.

10. Outside salesman, trade shows, website.

Physical Address For Service:
4123 North Banner Road
El Reno, OK 73036

ATTACHMENT A

Sewer Cleaning and Equipment for Trailer and Truck Mounting

(Examples: combination sewer cleaners, hydro-excavation trucks, truck jettiers, trailer jettiers, rodders, easement machines, vacuum trailers mounts, vacuum truck mounts) *****Vendor can provide a pricing list instead of this form.*****

YOU WILL NOT BE CONSIDERED RESPONSIVE IF YOU JUST FILL IN A BRAND AND "ALL MODELS". You must fill in Brand, Model Makes and Numbers and prices.

BRAND	MODEL (Standard Base Unit)	Price of Base Unit	Can be mounted on customer's already owned chassis?
Vac-Con	All units	-3% off	Yes
	see	factory list	
	attachment	price	
	for list	(factory list	
		price	
		attached)	
		*see below	

Attachments/Accessories: 3 % Multiple Unit discount * 1 % Parts 1 %
Options: 3 % Extended Warranty offered? X Yes No No. Attach information for the extended warranty.
Installation Charge: \$1,950.00 Hourly labor rate: \$110.00

Financing of Lease Purchase interest rate N/A %
Special Notes:
*additional 1% on multiple units (ordered at the same time)
for a total of 4%

NOTE: The discount given, only applies to the Vac-Con manufactured portion, not the chassis. We receive no discount on chassis prices. If chassis are to be provided by Frontier Equipment Sales, L.L.C they will be provided at the net price. No discounts are given on chassis. Chassis are sold for what they cost.

Physical Address for Service:
4123 North Banner Road
El Reno, OK 73036

ATTACHMENT A

Sewer Cleaning and Equipment for Trailer and Truck Mounting

(Examples: combination sewer cleaners, hydro-excavation trucks, truck jettors, trailer jettors, rodders, easement machines, vacuum trailers mounts, vacuum truck mounts)

*****Vendor can provide a pricing list instead of this form.*****

YOU WILL NOT BE CONSIDERED RESPONSIVE IF YOU JUST FILL IN A BRAND AND "ALL MODELS". You must fill in Brand, Model Makes and Numbers and prices.

BRAND	MODEL (Standard Base Unit)	Price of Base Unit	Can be mounted on customer's already owned chassis?
US Jetting	All units	+7% on	NO
	see	factory list	
	attachment	price	
	for list	(factory list	
		price	
		attached)	

Attachments/Accessories: 7 % Multiple Unit discount 0 % Parts 7 %

Options: 7 % Extended Warranty offered? Yes No. Attach information for the extended warranty.

Installation Charge: \$1,795.00 Hourly labor rate: \$110.00

Financing of Lease Purchase interest rate N/A %

Special Notes:



FRONTIER EQUIPMENT

P.O. Box 850114
 Yukon, Oklahoma 73085-0114

OFFICE
 405/354-2611 ■ Fax 405/354-2992

QUOTE

Date	QUOTE #
5/18/2018	QUOTE 2173

Name / Address
CITY OF ENID P.O. BOX 1768 ENID, OK 73702-1768

Ship To
CITY OF ENID STORM WATER 1500 WEST POPLAR ENID, OK 73703 ATTN:BRIAN BRUCE

Item	Description	Qty	Cost	Total
Misc. Parts	ONE NEW AND UNUSED SJ704020, 700 GALLON, 40 GPM @ 2000 PSI GIANT PUMP, 83.5 HP YANMAR DIESEL TIER III, 7000 # AXLE TANDEM. 1 - ROTATING HOSE REEL, SEALED HD BEARING 1 - 500' X 3/4" HOSE - 2500 PSI 1 - MODEL 785 GUN (800 PSI MAX) 1 - 25' X 1/2" WASHDOWN HOSE 1 - SELF RETRACTING HOSE REEL 25' (DOES NOT INC. HOSE) 1 - DELIVERY 1 - ONSITE TRAINING PRICING IS PER OKLAHOMA STATE CONTRACT# SW-193 OKLAHOMA STATE CONTRACT OFFICER: LINDA LECHTENBERG 405-522-0436 LINDA.LECHTENBERG@OEMS.OK.GOV	1	54,434.22	54,434.22

Subtotal		\$54,434.22
Sales Tax (0.0%)		\$0.00
Total		\$54,434.22

ALL QUOTES ARE GOOD FOR FIFTEEN DAY UNLESS OTHERWISE STATED ON QUOTE.



Statewide Contract Addendum

This addendum is added to and is to be considered part of the subject contract.

Contract Issuance Date: October 1, 2017

Statewide Contract #: SW193

Contract Title: Sewer Cleaning and Inspection Equipment

Addendum Date: January 24, 2018

Addendum #: 1

This addendum serves as notification of a Contracting Officer change. Linda Lechtenberg has now been assigned to this contract. Any questions can be directed to the Contracting Officer listed below:

Linda Lechtenberg
405-522-0436
Linda.Lechtenberg@omes.ok.gov



Notice of Statewide Contract Award

Official signed contract documents are on file with OMES-Central Purchasing.

Contract Title: Sewer Cleaning and Inspection Equipment

Statewide Contract #: SW 193

Contract Issuance Date: 10/01/2017

Total Number of Suppliers: Several *(For details see: Supplier Information Sheet)*

Contract Period: 10/01/2017 through 09/30/2018

Agreement Period: 10/01/2017 through **09/30/2022**

Authorized Users: This Contract shall be made available to all State Departments, Boards, Commissions, Agencies and Institutions. The Oklahoma Statutes also allow Counties, School Districts and Municipalities to use this contract as well as State entities other than the State of Oklahoma if statutes allow for it.

Contract Priority: Mandatory

Type of Contract: Fixed Price

OMES-CP Contact: Joyce Leivas

Phone: 1 - 405 - 521 - 479

Title: Contracting Officer

Fax: 1 - 405 - 521 - 4475

Email: Joyce.Leivas@omes.ok.gov

SEWER JETTER 350 / 700

350/ 700 gallon with multiple engine and pumps options

The John Bean Sewer Jetter requires only one operator and tows easily behind any standard duty pickup. A hydraulically driven hose reel mounted on an optional precision milled bearing system provides the user easy access to the line regardless of vehicle location. Many options are available such as: tool/accessory storage boxes that provide security, weather protection and easy operator access.



Standard Equipment

- Water capacity is your choice of 350 or 700 gallons consisting of two 350 gallon tanks made of total black poly LLDPE (linear low density polyethylene). Tank material is black and has a UV inhibitor which prevents the development of plant growth (i.e. algae, mold, etc.). The tank feature overhead air-gap fill and a curbside 2-1/2" brass fire hydrant fitting for easy and safe refill.
- Cold weather recirculation system allows water to be re-circulated through main hose and back to tank for sub-freezing operation
- The hose reel options:
 - Standard reel capacity is 600' of optional 3/4" or 800' of 1/2" high pressure hose and has air pressure cleanout connection
 - Dual reel capacities are 600' of 1/2" and 600' of 3/4" of high pressure hose (for 40 gpm @ 3000 psi only)

- Engine options are:

Engine Options (all have 2 year warranty)
Yanmar 83.5 hp Tier 3 turbo diesel or upgrade to Deere 80 hp Tier 3 Power Tech 4-cylinder
Deere 99 hp Tier 3 turbo diesel
Yanmar 83.5 hp Tier 3 turbo diesel or upgrade to Deere 80 hp Tier 3 Power Tech 4-cylinder
Yanmar 83.5 hp Tier 3 turbo diesel or upgrade to Deere 80 hp Tier 3 Power Tech 4-cylinder
Deere 115 hp Tier 3 turbocharged 4-cylinder diesel

- Pump options are:

Pump Options (all have 1 year warranty)
Giant 40 gpm @ 2000 psi or an alternate pump of FMC 40 gpm @ 2000 psi
Giant 40 gpm @ 3000 psi or an alternate pump of FMC 40 gpm @ 3000 psi
Giant 18 gpm @ 4000 psi
Giant 25 gpm @ 4000 psi
Giant 65 gpm @ 2000 psi

- Yanmar engines have digital electronic control panel that presents an hour meter, oil pressure, voltage and throttle control. Kubota engine has hour meter, LED lights to monitor oil pressure, voltage and water temperature. Deere engines have analog panel with Murphy safety shutdown switch. All control cabinets come standard with ignition switch, water pressure gauge, reel speed control, reel in/out control, toggle switch for electric clutch and emergency stop
- Auxiliary outlet with cutoff piped to curbside for optional wash down system
- 16 gallon aluminum diamond plate fuel tank
- Beacon light mounted over engine enclosure
- 12 volt battery
- Hydraulic temp gauge
- One each 20° and 30° cleaning nozzle, one heavy duty 15” tubular nozzle extension and heavy duty hose guide (Tiger Tail)
- Electric linear actuated, spring loaded clutch for pump engagement /disengagement
- Heavy duty pressure regulator
- Engine shroud covers engine, pump and belt drive
- Trailer features:
 - Single or tandem axle configurations for 7000 or 14000 GVWR, tires are LT235/85R16 12-ply, electric brakes, 2-5/16” ball hitch, DOT approved rubber mounted LED lights, PPG Commercial Performance paint (trailer and reel)

Warranty is standard 1 year parts & labor, with exception of tank (5) and engine (2) years

City Commission Meeting

7.4.

Meeting Date: 06/19/2018

Submitted By: Kelley Munkres, Administrative Assistant

SUBJECT:

AWARD CONTRACT FOR REMOTE SCHOOL BEACON MONITORING SYSTEM TO GADES SALES COMPANY, INC., WICHITA, KANSAS, IN THE AMOUNT OF \$116,308.00, AND AUTHORIZE THE MAYOR TO EXECUTE ALL CONTRACT DOCUMENTS.

BACKGROUND:

Bids were solicited and opened on May 8, 2018 for a Remote School Beacon Monitoring System. This system will display real time fault status of the City’s school beacons, including loss of AC power, beacon failure, battery failures and solar charge status. Gades Sales Company, Inc. was the only responsive bidder with a bid of \$116,308.00. Cost breakdown is as follows:

Item & Description	Quantity	Total Price
School Beacon Timer Switch	44	\$72,952.00
5 Year Connectivity & Support	44	\$40,040.00
Spare School Beacon Timer Switch	2	\$3,316.00
		\$116,308.00

RECOMMENDATION:

Award contract to Gades Sales Company, Inc. in the amount of \$116,308.00

PRESENTER:

Everett Glenn, Public Works Director

Fiscal Impact

Budgeted Y/N: Y

Amount: \$116,308.00

Funding Source:

40-405-9151

Attachments

Bid
Specifications

SOLICITATION FOR BIDS
(Bid Notice)

Sealed bids will be received by the City of Enid, Oklahoma, a Municipal Corporation, at the office of the City Clerk of said City, located in the Dr. Martin Luther King, Jr. Municipal Complex, 401 West Owen K. Garriott Road, P.O. Box 1768, Enid, Oklahoma, until 2:00 P.M. Local Time on the 8th day of May 2018, for furnishing:

REMOTE SCHOOL BEACON MONITORING SYSTEM (RSBMS)

Said bids will be publicly opened and read aloud at 2:10 P.M. on the 8th day of May 2018, in the office of the City Clerk. All bids will remain on file in the office of the City Clerk.

At a later date, the Mayor and Board of Commissioners will meet to award the contract. All bids must be in accordance with the specifications on file in the office of the City Clerk which are made a part thereof.

Bids received after the final time set for receipt of bids will not be considered and will be returned unopened.

Specifications may be procured or examined without charge in the City Clerk's Office.

No bid may be withdrawn after the scheduled time for receipt of bids for at least sixty (60) days.

The City of Enid reserves the right to reject any and all bids and to waive informalities. Should the bidder be unable to meet or exceed the stated specifications, he may submit a bid which best meets the City's specifications. It may, at its option, award a contract to the bidder whose bid best satisfies the requirements contained within the specifications as determined by the City Commission.

Each bidder shall attach complete description with his bid. Bid shall be F.O.B. Enid, Oklahoma with Oklahoma State, local and Federal tax excluded.

A completed and executed Business Relationships Affidavit and Non-Collusion Affidavit shall accompany the sealed bid of each bidder or bid may be rejected.

Should more than one bid be submitted for the same receipt date, whether on the same item or different items, each bid shall be enclosed in a separate envelope with proposal sheet on top.

DATED this 19th day of April 2018.

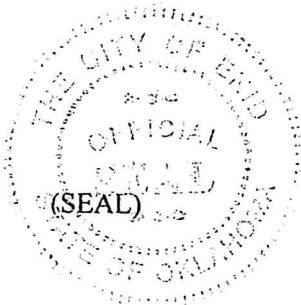

CITY OF ENID, OKLAHOMA

BY: *Miriam L. Jack*
City Clerk

PROPOSAL

To: Mayor and Board of Commissioners
City of Enid, Oklahoma

We, the undersigned, do hereby propose to furnish F.O.B. to the City of Enid, Oklahoma, with Oklahoma State, Local and Federal Tax excluded, Remote School Beacon Monitoring System (RSBMS), in compliance with the specifications at the following price to-wit:

PRODUCT	QUANTITY	COST PER UNIT
SCHOOL BEACON TIMER SWITCH AND CELLULAR MODEM	<u>44</u>	<u>\$ 1,658.00</u>
5 YEAR CONNECTIVITY & SUPPORT	<u>44</u>	<u>\$ 910.00</u>
SPARE SCHOOL BEACON TIMER SWITCH AND CELLULAR MODEM	<u>2</u>	<u>\$ 1,658.00</u>
HIGH GAIN ANTENNAS (IF NEEDED)	<u>Ø</u>	<u>\$ (100.00) if needed</u>
GRAND TOTAL		<u>\$ 116,308.00</u>

DELIVERY DATE 4-6 weeks ARO

Bidder: Charles Sales Company Inc.

Street Address: 5801 West Harry St.

City, State, Zip Code: Wichita, KS. 67209

Telephone Number: 316-943-1219

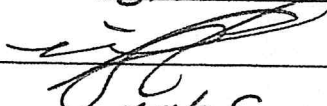
Signed by:  Date: 5-1-18

Printed Name: Mike Searek Title: General Manager

Question: Frank Sweet, Tech Services, (580) 616-7338



NON-COLLUSION AFFIDAVIT

To Accompany Contractor's Bid

STATE OF Kansas)
COUNTY OF Sedgwick) ss:

MIKE SEARLE (Contractor's Authorized Agent), of lawful age, being first duly sworn upon his/her oath, states:

- 1. I am the duly authorized agent of Grades Sales Company Inc. (Bidder's Company Name), the bidder submitting the attached competitive bid (the "bid"), for the purpose of certifying the facts pertaining to the existence or nonexistence of collusion among bidders or between bidders and municipal officials or employees, as well as facts pertaining to the giving or offering of things of value to government personnel in return for special consideration in the award of any contract associated with the bid attached to this document;
2. I am fully aware of the facts and circumstances surrounding the making of the bid and have been personally and directly involved in the proceedings leading to the submission of such bid;
3. Neither the bidder nor anyone subject to the bidder's direction or control has been a party to: Any collusion among bidders to restrain the freedom of competition by agreement to bid at a fixed price or to refrain from bidding; Any collusion with any municipal official or employee as to quantity, quality, or price in the bid or contemplated contract, or as to any other terms of such bid or contemplated contract; nor any discussions between bidders and nay municipal official or employee concerning the exchange of money or other thing of value for special consideration in the award of the contemplated contract.

Further, Affiant saith not.

Signature of Authorized Agent
General Manager
Title (printed)

Subscribed and sworn to before me this 1st day of May, 2018.

(SEAL)

My commission expires:

9-6-2021

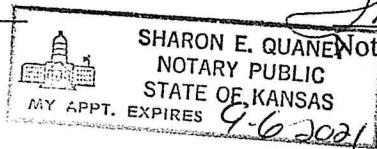

Sharon E. Quane
Notary Public



BUSINESS RELATIONSHIP AFFIDAVIT

To Accompany Contractor's Bid

STATE OF Kansas)
COUNTY OF Sedgwick) ss:

Mike Searle (Contractor's Authorized Agent), of lawful age, being first duly sworn upon his/her oath, states:

- 1. I am the duly authorized agent of Grades Sales Company Inc. (Bidder's Company Name), the bidder submitting the attached competitive bid (the "bid").
2. My position in the above named company is General Manager.
3. Affiant further states the nature of any partnership, joint venture, or other business relationship presently in effect, or which existed within one (1) year prior to the date of this Affidavit, with the architect, engineer, or other party to the project is as follows:

None
(if none, so state)

- 4. Affiant further states that any such business relationship presently in effect or which existed within one (1) year prior to the date of this Affidavit between any official or director of the architectural or engineering firm or any other party to the project is as follows:

None
(if none, so state)

5. Affiant further states that the names of all persons who have any such business relationship and the positions they hold with their respective companies or firms are as follows:

(if none, so state)

Further, Affiant saith not.

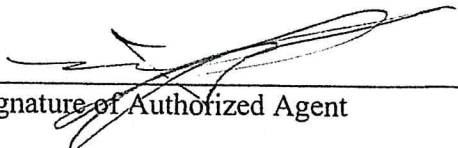

Signature of Authorized Agent

General Manager

Title (printed)

Subscribed and sworn to before me this 15th day of May, 2018.

(SEAL)

My commission expires:

9-6-2021

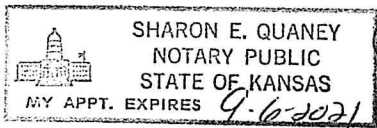

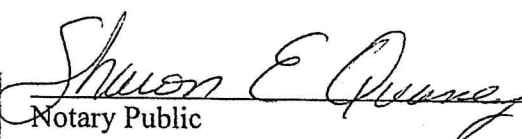

Notary Public

NOTICE

Bid envelope shall be plainly marked on the outside as follows:

Remote School Beacon Monitoring System (RSBMS)

Should more than one bid be submitted for the same receipt date, on the same item, each bid shall be enclosed in a separate envelope.

Specification for a Remote School Beacon Monitoring System (RSBMS)

Overview

Traffic Control in Tech Services wishes to procure a city wide Remote School Beacon Monitoring System (the RSBMS). The intention of the RSBMS is to allow the following key requirements to be implemented:

- 1) Display of the real time fault status of the City's school beacons, including loss of AC power, beacon failure, battery failures and solar charge status.
- 2) Issue real time alerts via SMS and email to the appropriate response personnel immediately after a fault occurs, so that Traffic Control no longer has to rely on notification by the public.
- 3) Setting up the schedules and holidays of school beacon operation remotely, and downloading the schedules to the school beacons.
- 4) Having manual override of individual or groups of school beacons to be able to turn them immediately on or off to meet early school release, and other unexpected school events.
- 5) Operating the RSBMS with cloud hosted software with user web based access, and with no software or IT infrastructure for Traffic Control to install or maintain. The client user interface will be browser based, with no software to be installed on client computers except for a standard web browser.
- 6) The timer switch shall be capable of being programmed locally via a laptop interface.
- 7) Key performance indicators must be maintained by the system and reported at the end of each week. These reports will showcase the operational availability of school beacons. The report shall include details of the beacon health condition of the battery's, solar chargers and lamps.
- 8) The timer switch must be capable of collecting radar speed data to determine if vehicles are slowing down in a school zone. This system must display the median speed, 85th percentile speed and volume of vehicles in the roadway, reported every 15 minutes. This functionality (if the school beacons are fitted with optional speed radars) will enable the City to determine which schools have a speed enforcement problem, both when the beacons are on and off.
- 9) The timer switch shall also include the ability to control radar feedback signs. This shall include turning the display board on/off and configuring the speed thresholds. This shall include configuring at a minimum; Steady Speed; Flash Speed; Slow Down Message Speed; Max Speed. The interface shall also include the ability to set the sign to always display speed feedback information or only to display speed feedback information on a schedule.
- 10) The timer switch shall be capable of monitoring rapid flashing beacons, this includes battery voltage, solar panel, AC and the number of button presses.
- 11) The same timer switch shall be capable of operating with AC and DC environments. The relay outputs should be rated at 16A.
- 12) The Traffic Control is requiring the system to form part of an overall Smart City Management platform. To this extent the proposed system shall be able to be expandable to include intersection monitoring and management; priority and preemption monitoring and management; weather systems and other Smart City applications.
- 13) System support is very important to Traffic Control. The Vendor shall have both field-installation technical support, as well as operator/programming/system support located near the City of Enid.

- 14) The timer switch must be capable of receiving “over the air” software and security updates. The over the air updates allows new features to be installed remotely without having to physically go to the school beacons.
- 15) The timer switch shall be connected vehicle ready and be capable of broadcasting safety messages to motorists. The timer switch shall support the SAE J2735 standard for connected vehicle messages. The timer switch shall support both cellular and optional DSRC technology to broadcast the safety messages.
- 16) The hardware shall be under warranty for as long as the devices have a connectivity and support license and connected to the Remote Beacon Monitoring System.

A. Remote School Beacon Monitoring System Client User Interface Requirements.

The RSBMS software user interface shall provide, as a minimum, features to meet the following requirements:

1) General

- a. The user interface shall be web based, and to be able to be viewed using a browser. Internet Explorer, Chrome and Firefox browsers shall be supported, as well as Safari on an iPad. Systems that use remote desktop or similar to view a thick-client user interface will not be acceptable.
- b. The RSBMS shall require a user name and password to log on.
- c. The RSBMS systems shall be mobile friendly and operators shall be able to open the system on a mobile phone to access the data and control the school beacons. The web based system shall be viewable on any modern web browser on a mobile phone and automatically sized for the screen.

2) Map Display

- a. The RSBMS shall include a scrollable, zoomable map display, with the school beacons shown as representative icons on the map. The map display must have option to select either satellite view or normal street map view. The map shall include the ability to see the school beacons using Google Street view.
- b. The alarm status of the school beacon shall be clearly indicated on the icon on the map, so that the user can see at a glance which school beacons are in alarm.
- c. The status of all beacons shall include if the beacon is currently on and if the beacon has a schedule mismatch.
- d. The map display shall also include a list of school beacons, with the number and priority of alarms indicated on the list. School beacons in high priority alarm shall be moved to the top of the list, followed by medium priority, low priority and then finally by school beacons not in alarm.
- e. The icons shall change to be able to clearly indicate if a school beacon is offline.
- f. Clicking on the icon on the map shall expose a box with the current parameters of the school beacon shown.
- g. The default map display position and zoom shall be configurable by user, so that the user’s view will default to show the school beacons that the user is responsible for managing.

- h. The map display shall allow for multiple preset zoom layers. This allows users to select preset zoom layers to zoom into different areas of the map. This shall make managing multiple school districts easier.
- i. The map display shall have a pop out that allows operators to turn on layers. Layers shall include the ability to display the device names of every beacon on the map display. Operators shall also be able to Google traffic overlay information so that operators can see the traffic together with the school beacons. The pop out shall also include the option to automatically zoom into a selected device.

3) Regional School Beacon Grouping

- a. The RSBMS shall provide for school beacons to be logically grouped into regional groupings (for example, north; south; east or west)
- b. The RSBMS user logon shall be configurable so that if a maintenance person is responsible for, say, the north school beacons then when that user logs on, the user has visible only the school beacons that belong to the group that the user is authorized to view.
- c. Users shall also be able to save the map zoom level for their individual log in.
- d. Users shall be able to select multiple preset zoom options to zoom into different areas of the maps.

4) School Beacon Detail Display

- a. It shall be possible to drill down, either from the map icon or from the list, to a device level detail for the school beacon, which as a minimum shall display the following parameters:
 - i. The alarm status, with priority indicated, and a text description of the alarm (if an alarm is present for this device).
 - ii. The time since the last communication with the device
 - iii. The following parameters (real time now values, minimum for the day values, maximum for the day values, and average for the day values)
 - 1. The AC mains voltage (value)
 - 2. The battery voltage (value)
 - 3. The battery back-up voltage (value)
 - 4. The solar charge voltage (value)
 - 5. The presence of AC power (OK or Fail)
 - 6. The current status of the school beacon (On or off, and whether under manual or schedule control)
 - 7. Beacon failure state (One beacon failure or both beacon failure)
 - 8. The cabinet door status (Open or Closed)
 - 9. Whether the school beacon is in local manual override control
 - iv. It shall be possible to view real time graphs of each of the value parameters in graphical form, over the recent one week period. This includes real time graphs of:
 - 1. The AC mains voltage
 - 2. The battery voltage
 - 3. The battery back-up voltage

4. The solar charge voltage
 5. The beacon failure state (one beacon failure or both beacon failure or okay)
 6. The status of the school beacon state (schedule on, schedule off, manual on, manual off, local override on, local override off)
- v. It shall be possible to view real time graphs of vehicle speeds and volume when a radar unit is connected to the school beacon timer switch. This includes real time graphs of:
1. The median speed
 2. The 85th percentile speed
 3. The volume of vehicles per hour.
- vi. The graphs shall be displayed together in the detail display. Clicking on any of the graphs shall cause the graph selected to enlarge, so that additional detail can be seen.

5) School Beacon Individual Remote Override

- a. From the browser user interface it shall be possible to remotely override the state of the beacon, and place the beacon into state "manual on" or "manual off".
- b. The beacons shall change state within 30 seconds of the command being issued.
- c. The user interface shall update within 60 seconds to show the actual state of the beacon, so that the user can readily confirm that the remote manual override was successfully executed by the beacon.
- d. The graphical display of the beacon state shall be updated to "manual on" or "manual off", as applicable, so that it is easy to see when the remote manual override command was issued.
- e. The remote manual override command shall be recorded in the user log so that an audit trail will be able to tell which user issued the remote manual override command.

6) School Beacon Scenario Remote Override

- a. It shall be possible to create Remote Scenarios in preparation for unexpected events that typically occur for school beacons. This includes being able to group school beacons into a district, and then turn the beacons in the district on; or off; or back to schedule using a single click on the user interface.
- b. Setting up and then using these scenarios shall make it easy to change the school beacons for weather events, early release and other short term changes to the scheduled operation of the beacons.

7) School Beacon Remote Scheduling

- a. It shall be possible to create scheduled events for the school beacons, and publish these schedules to the field controller. The field controller will then store locally in non-volatile memory and use the schedule to operate the school beacon at the correct time.

- b. The field controller will update its internal time clock from the server and/or the GPS to ensure that the field controller's clock remains accurate to within 1 minute of the actual time.
- c. It shall be possible to schedule the school beacon plans to turn the beacon on or off by time of day, by day of week and by month of year.
- d. It shall be possible to include holidays and exception schedules. These holidays should automatically turn the school beacon off during holidays. It shall also be possible to create exception days that switch to a different schedule on that specific day. Holidays and exception days shall have a calendar pop out to select the specific date.
- e. It shall be possible to publish the schedule to one beacon or a group of beacons simultaneously.
- f. The schedule shall display in summarized form the time, day(s) of week and month(s) of the year that the schedule is to operate in a summary form, so that it is easy to read the list of schedules.
- g. On the detailed display, the user interface shall display the date, time, and operation for the next seven scheduled events. In this way, it shall be easy to understand the planned operation of the schedule that is currently published to the device. The next scheduled event information should take into account holiday and exception days as well as schedule delays due to weather events.
- h. Scheduling shall include the option to delay, advance or cancel the schedule due to weather events. This schedule delay will only effect the selected days schedule and the following day the schedule will revert back to normal. Users shall have the option to select today, tomorrow or any selected date. User shall also be able to select to only delay the morning schedule or the afternoon schedule or both.
- i. Only users with access rights will be able to change beacon schedules and holiday.
- j. The system must have the ability to determine if there is a "schedule mismatch". This means the schedule that is stored in the central is different to the schedule in the devices. The system must indicate which devices have a schedule mismatch and users can see what caused this. Once an operator downloads the correct schedule these mismatches will clear.
- k. Scheduling shall also do error checking to determine if the operator has made any errors while making the schedule. This includes overlapping holidays and exception days as well as consecutive on or off commands.
- l. Scheduling shall also include the ability to control connected driver feedback signs. This shall include turning the driver feedback display board on/off and configuring the speed thresholds. This shall include configuring at a minimum; Steady Speed; Flash Speed; Slow Down Message Speed; Max Speed and speed threshold difference. The interface shall also include the ability to set the sign to always display speed feedback information or only to display speed feedback information on a schedule. If the sign is set to always on the speed thresholds will change when the school beacons are on due to the speed limit changing.

8) Diagnostics and Log Display

- a. From the device level detail, it shall be possible to further drill down to get the raw data; the error logs; and the communications logs to allow a technician to fault-find problems on the RSBMS.
- b. It shall be possible to filter the logs by Device, by Device Type and/or by Group as well as between dates.
- c. It shall be possible to print these selected logs to a local printer or a PDF file.
- d. It shall be possible to export these logs to Excel on the local computer for further analysis.

9) Alarms

- a. The RSBMS shall have a comprehensive alarm generation capability
- b. It shall be possible to configure alarms to be generated on any parameter becoming out of tolerance, including analog values, digital values and enumerated values.
- c. Alarms shall include at a minimum: AC power failure; Low Battery Voltage; Low Solar Charge Voltage; One Beacon Failure and Both Beacons Failure
- d. Alarms shall be configurable to be of Low, High or Critical Priority.
- e. The alarm priority shall be displayed throughout the RSBMS, on all displays, using color codes such as red-critical; yellow-high; and amber-low to indicate the priority of the alarm.
- f. The current active alarms shall be accessible for view via an expandable window, to see which alarms are active and when the alarm occurred. The highest priority alarms shall rise to the top of the list.

10) Alerts

- a. The RSBMS shall have comprehensive alerting capability, to enable the response personnel to be notified when an abnormal situation has occurred.
- b. It shall be possible to configure alerts to one or more personnel for each alarm. This will cause, as selected, a text message and/or an email to be sent to the person when an alarm occurs.
- c. The alert shall be configurable to optionally send via email and/or via text message a message when an alarm clears.
- d. The intention is that the RSBMS provides the alerts to the user in near real time. The text message and email shall be issued within 30 seconds of the occurrence of an event which results in an alert being issued.

11) Reports

- a. It shall be possible to view reports on the screen, in the browser of the RSBMS, and if desired print the report to a printer or a PDF file.
- b. Alarm Activity Report
 - i. The RSBMS shall include a report which shows the alarms activity for a period.
 - ii. The Alarm Report shall indicate the time the alarm occurred; by color the priority of the alarm; whether it is still active; and if not active then the time that the alarm cleared.
 - iii. It shall be possible to filter the alarms by Device Type; by Device and/or by Device Group as well as by date time to be able drill down into a large alarm list to be able

to view, for example, the alarm activity for a particular school beacon over a three month period

- c. User Activity Report
 - i. The RSBMS shall include a report which shows user activity for a given period, to enable an audit of a user's response to an alarm to be made.
 - ii. The report shall show which screens the user viewed, when the screen was viewed, and the IP address of the computer from which the screen was viewed.
- d. School beacon Operational Availability Report
 - i. The RSBMS shall include a report which shows the overall operational availability of the City's school beacons. The school beacon is available when not in an alarm condition such as power fail.
 - ii. The report shall include information on what battery status, solar status, AC status and Beacon status. These should show a color coded display on which beacons are functioning correctly and which beacons are starting to fail.
 - iii. The report shall also be able to show only beacons that are in fault.
- e. Response Time for Fault Repair Report
 - i. The RSBMS shall include a report which shows the response time to clear faults, for a given time frame (say 1 month).
 - ii. This report will allow the user to determine the number of faults, and the total and average time to clear the fault.
 - iii. This report will allow the response times by region to be compared.

12) MAP files for connected vehicles.

- a. The RSBMS shall include a web based configuration tool for setting up the MAP messages for capturing the school beacon geometry for connected vehicle applications. Input for this MAP configuration utility includes configuring lanes by drawing the lanes on a google map image. Lanes are linked to school beacon activation data so that users get the correct information when they are approaching on a specific lane. The map files also contain the speed limit when the school beacons are activated to be broadcast to the motorists. Once configured these MAP files are saved at each school beacon as well being saved on a cloud server where they would be available for use by the connected vehicle system.
- b. The timer switch is connected to the server where the MAP files are stored and securely checks the status of the MAP files. Anytime the MAP file stored on the server is changed the timer switch securely retrieves the revised MAP file, and stores it locally at the intersection. The contents of the MAP file are then encoded in accordance with J2735 to make a MAP message, which is then broadcast out over cellular and or DSRC radio once per second.
- c. It shall be possible to configure the following items in this file.
 - i. The approach lanes by drawing a set of points on a Google map that define the lane. The lane width shall also be configurable to define the size of the lane.
 - ii. Each lane approach shall include the name of the school
 - iii. Each lane shall have the speed limit when the school beacon is activated.

13) Smart phone connected vehicle display

- a. The smart phone application shall provide audible alerts to users. The application shall not require any user interaction and shall always run in the background.
- b. User shall be capable of also receiving visual alerts via the smart phone application.
- c. Users shall be capable of seeing speed limits for active school zones and receive warnings when speeding in an active school zone.
- d. Users shall have the ability to turn on/off audible alarms for the various applications.
- e. Users shall be capable of overriding the application to become a pedestrian, cyclist or motorist.
- f. The smart phone application shall support the following applications as standard:
 - a. SPaT/MAP display of signal timing – V2I
 - b. Red-light running at traffic signals – V2I
 - c. Emergency vehicle and bus priority – V2I
 - d. Direction of approaching emergency vehicle – V2V
 - e. Intelligent cross walks – V2I
 - f. Intelligent school beacons – V2I
 - g. Motorist to Cyclist and Pedestrians Warnings - V2V
 - h. Rear end collision warning – V2V
 - i. Virtual/advance traffic detectors at traffic signals – V2I
 - j. Curve warning/reduce speed – V2I
 - k. Wrong way detection – V2I

1) Intelligent School Beacon Overall Requirements

- a. The system must integrate into the school beacon cabinet and shall broadcast a message when the beacon is activated with the new applicable speed information.
- b. When a motorist drives through an active school zone area and is driving faster than the school zone speed limit they shall be alerted that he is in an active school zone.
- c. The application shall provide the operator with the speed limit information when driving inside an active school zone.
- d. When the driver is driving below the speed limit alarms shall disappear.
- e. Once outside the school zone area the driver shall stop receiving information from the school zone.

B. Field Device Requirements

It is a requirement that the RSBMS operate independently of the brand/type of school beacon controller that has previously been deployed. The RSBMS contractor shall install a retro-fit School Beacon Timer and Cellular Modem/Remote School Beacon Management System Field Device into existing school beacon cabinet assemblies:

- 1) The Remote School Beacon Management System Field Device (RSBMSFD) / School Beacon Timer and Cellular Modem device includes:
 - a. A small field controller which includes an integrated cell modem, GPS and all other inputs and outputs required for the correct operation of the system.

- b. Local Scheduling via a laptop using an internet browser. The unit shall include a Ethernet port to locally program the beacon schedules.
- c. The same unit should be able to operate with either AC or DC power.
- d. Monitoring signals such as AC, battery voltage, solar charge voltage and integrated battery backup voltage.
- e. A local override switch to place the beacon in on, off, or schedule control.
- f. Monitor the lamp current to determine if both lamps are working or if only one lamp is working.
- g. Capable of monitoring the door status of the cabinet.
- h. The unit shall include 2 relay output so that it can control 2 flasher controller units.
- i. The RSBMSFD unit shall include an extended warrantee for the entire time it is connected to the Remote School Beacon Management Systems.
- j. The RSBMSFD warrantee shall also include replacing the cellular modem if the cellular technology changes. Such as 2G-3G or 4G-5G.

The RSBMS Field Device (RSBMSFD) shall conform to the following requirements:

- 2) The RSBMSFD shall function correctly between -34 degrees C and +74 degrees C.
- 3) The RSBMSFD shall be provided with appropriately rated and keyed connectors that allows the RSBMSFD to be exchanged by unplugging connectors, without tools.
- 4) The RSBMSFD shall incorporate an integrated GPS and cell modem.
- 5) The RSBMSFD shall be capable of using 3rd party SIM cards provided by the City.
- 6) The configuration of the RSBMSFD shall be accomplished by accessing the internal web server with a browser. It shall be possible to configure the RSBMSFD without any special software.
- 7) The RSBMSFD shall utilize field initiated communications. This allows for low cost cellular data plans to be used, with infrequent polling. However, when an abnormal event occurs and is detected by the RSBMSFD, then the RSBMSFD will immediately initiate the transfer of a data packet to the RSBMS to enable real-time alerting of response personnel to take place.
- 8) The RSBMSFD shall include a battery and battery charging/monitoring circuit, to allow the RSBMSFD to function correctly even when all power to the school beacon has failed. The battery shall continue to power the RSBMSFD controller and cell modem for a minimum of 5 hours after all power has failed to the school beacon.
- 9) The RSBMSFD shall incorporate an integrated GPS which will allow the RSBMSFD to geo-locate itself on the map, without configuration.
- 10) The same timer switch shall be capable of operating with AC and DC environments. The relay outputs should be rated at 16A.
- 11) The RSBMSFD shall operate without requiring a static IP address. The only configuration required at the RSBMSFD is to enter the URL of where the RSBMS central software is hosted.
- 12) In the event that the cell service is interrupted or is not available, the RSBMSFD shall store any events that occur in internal memory, and forward these events automatically to the RSBMS when the cell service is restored. In this way, a complete record of events at the device can be maintained even if cell service is interrupted for a period.

- 13) The RSBMSFD shall utilize HTTP and HTTPS protocols, and XML data structures, for communications with the RSBMS. In this way, the data will be open for future expansion and competition. The use of secret proprietary protocols is not permitted.
- 14) The RSBMSFD shall support Ethernet and cellular communications. The primary communication shall be Ethernet, and in the event of the Ethernet communication not being successful then the RSBMSFD shall switch over to the back-up cellular communications.

C. Installation

All installation work in the City of Enid cabinets shall be carried out by personnel certified by the City for work in City of Enid traffic cabinets.

D. Commissioning, Training and Documentation

The RSBMS contractor shall configure the system and reports, and train the City of Enid Traffic Control department in the correct operation of the RSBMS, to enable the City of Enid to utilize the RSBMS for the objectives outlined above.

E. Hosting and Connectivity and Service.

The RSBMS contractor, as part of the quote, shall include 5 or 10 years options for Connectivity and Service, as part of the purchase price. The RSBMS contractor, as part of the response to this RFQ, shall provide the option to extend the operation for a further 5 years of the Connectivity and Service agreement of the RSBMS.

The Connectivity and Service agreement shall include at a minimum:

- Cellular Connectivity
- Upgrade the cellular modem if the technology is not supported by the cellular networks.
- Telephone and email support
- No cellular overage charges
- Extended warranty on the hardware for the period of the Connectivity and Service Agreement
- Over-the-air software updates
- Over-the-air security updates
- Future Connected Vehicles Service

F. Extensibility

The RSBMS shall be designed to be extensible to cover the monitoring, maintenance and operations of additional ITS systems such as:

- 1) Intersection monitoring systems
- 2) Emergency Preemption & Priority Systems
- 3) Speed Feedback Radars
- 4) Dynamic message signs

- 5) Mobile systems such as maintenance vehicles, and emergency response vehicles.
- 6) Traffic detection systems.
- 7) ITS cabinet monitoring systems.
- 8) Remote Weather Information Systems (RWIS)
- 9) Over-height vehicle detection and warning systems
- 10) High Mast lighting control systems

City Commission Meeting

7.5.

Meeting Date: 06/19/2018

Submitted By: Jacqueline Cook, Engineering EA

SUBJECT:

RENEW THE ADMINISTRATIVE SERVICES AGREEMENT BETWEEN THE CITY OF ENID AND BLUECROSS BLUESHIELD OF OKLAHOMA FOR THIRD PARTY ADMINISTRATION OF THE CITY OF ENID'S SELF FUNDED EMPLOYEE HEALTH INSURANCE PLAN AND DENTAL PLAN, PROVIDE COBRA ADMINISTRATION AND ADD STOP LOSS COVERAGE.

BACKGROUND:

For fiscal year 2018-2019, the renewal cost for administrative services is \$38.19 per covered employee per month, approximately \$197,518.00 annually based on estimated enrollment of 431 members. The City of Enid also purchases stop loss insurance to protect the health fund in the event the City's total claims would exceed \$5,281,674.00 or an individual's claims would exceed \$175,000.00. The renewal fee for aggregate is \$5.07 per employee per month and individual stop loss is \$73.59 per month, per covered employee, approximately \$406,829.00 annually based on average enrollment of 431 members. However, Bluecross Blueshield is offering a one month holiday from third party administration fees for the return of business. This discount equates to approximately \$16,460.00 and coupled with the reduction of the administration fees and reporting fees for using an outside Stop Loss provider will reduce the total to approximately \$347,000.00. The renewal fee for dental administration is \$4.37 per employee per month, approximately \$22,601.00 annually based on average enrollment of 431 members. The City also uses Blue Cross/Blue Shield's COBRA Administration services at a total cost of \$75.00 for the monthly administrative fee, and \$10.00 for each notification event. The cost of providing these benefits is budgeted in the Health Fund, and is off-set by employee premium contributions of approximately \$775,000.00 annually and approximately \$195,000.00 in retiree contributions.

RECOMMENDATION:

Approve renewal.

PRESENTER:

Sonya Key, Human Resources Director

Attachments

ASO Renewal
Stop Loss Exhibit

Benefit Program Application ("ASO BPA")

Applicable to Administrative Services Only (ASO) Group Accounts

administered by Blue Cross and Blue Shield of Oklahoma, a Division of Health Care Service Corporation, a Mutual Legal Reserve Company, hereinafter referred to as "Claim Administrator" or "HCSC"

Group Status: Renewing ASO Account

Employer Account Number (6-digits): YN9836

Group Number(s): YN9836,
DN9836

Section Number(s): YN9836:
1001,1002,1003,1004,1005,1006,
2001,2002,2003,2004,2005,2006
DN9836:1001,1002,1003,1004,
1005,1006,

Legal Employer Name: The City of Enid

(Specify the Employer or the employee trust applying for coverage. Names of subsidiary or affiliated companies to be covered must be named below. AN EMPLOYEE BENEFIT PLAN MAY NOT BE NAMED)

ERISA Regulated Group Health Plan*: Yes No

Is your ERISA Plan Year* a period of 12 months beginning on the Anniversary Date specified below? Yes
If not, please specify your ERISA Plan Year*: Beginning Date ___/___/___ End Date ___/___/___ (month/day/year)

ERISA Plan Administrator*:

Plan Administrator's Address:

If you maintain that ERISA is not applicable to your group health plan, give legal reason for exemption:
Non-Federal Governmental Plan (Public Entity) ; if applicable, specify other: _____

Is your Non-ERISA Plan Year* a period of 12 months beginning on the Anniversary Date specified below? Yes
If not, please specify your Non-ERISA Plan Year*: Beginning Date ___/___/___ End Date ___/___/___ (month/day/year)

For more information regarding ERISA, contact your Legal Advisor.

*All as defined by ERISA and/or other applicable law/regulations

Effective Date of Coverage: (Month/Day/Year) 07 / 01 / 2018

Anniversary Date: (Month/Day/Year) 07 / 01 / 2019

Account Information

NO CHANGES SEE ADDITIONAL PROVISIONS

Standard Industry Code (SIC): 9111

Employer Identification Number (EIN): 736005197

Address: P.O. Box 1768

City: Enid

State: OK

ZIP: 73702-1768

Administrative Contact: Sonya Key

Title: HR Director

Email Address: skey@enid.org

Phone Number: (580) 234-4000
Ext. 7205

Fax: (580) 234-8946

Wholly Owned Subsidiaries:

Affiliated Companies:

(If Subsidiaries or Affiliated Companies listed above are to be covered, Employer hereby confirms that Employer and the listed Subsidiaries and/or Affiliates are treated as a single employer under Internal Revenue Code Section 414(b), (c) or (m).)

Blue Access for Employers (BAE) Contact: Sonya Key

(The BAE Contact is the Employee authorized by the Employer to access and maintain the Employer's account in BAE.)

Email Address: skey@enid.org

Phone Number: (580) 234-0400 Ext. 7250

Fax Number: (580) 234-8946

The Employer or other company listed in this BPA is a public entity or governmental agency/contractor

Producer of Record

NO CHANGES SEE ADDITIONAL PROVISION

Effective: 07/01/2018

If applicable, the below-named producer(s) or agency(ies) is/are recognized as the Employer's Producer of Record (POR) to act as representative in negotiations with and to receive commissions from Blue Cross and Blue Shield of Oklahoma, a division of Health Care Service Corporation (HCSC), a Mutual Legal Reserve Company, and HCSC subsidiaries for Employer's employee benefit programs. This statement rescinds any and all previous POR appointments for the Employer. The POR is authorized to perform membership transactions on behalf of the Employer. This appointment will

Proprietary and Confidential Information of Claim Administrator

Not for use or disclosure outside Claim Administrator, Employer, their respective affiliated companies and third party representatives, except with written permission of Claim Administrator.

remain in effect until withdrawn or superseded in writing by Employer.

Are commissions to be paid? Yes No

Producer or Agency to whom commissions are to be paid*: Holmes, Murphy & Associates

Tax ID Number (TIN) of Producer or Agency: 420985055 Producer #: 002736000

NPN:

Address: 12712 Park Central Drive Suite 100

City: Dallas

State: TX

ZIP: 75251

Phone: (214) 265-6658

Fax: (214) 346-6799

Email: myoung@holmesmurphy.com

Is Producer/Agency appointed with HCSC in Oklahoma? Yes No

Commissions:

PCPM \$ Does a Monthly Cap Apply Yes No \$ (If cap is annual, divide by twelve)

Flat \$ Does a Monthly Cap Apply Yes No \$ (If cap is annual, divide by twelve)

Percentage of Stop Loss: % Fees Single: \$ Family: \$ Aggregate: \$

* The Producer or agency name(s) above to whom commissions are to be paid must exactly match the name(s) on the appointment application(s).

Additional Comments: _____

Schedule of Eligibility

NO CHANGES

SEE ADDITIONAL PROVISIONS

Employer has made the following eligibility decisions

1. Eligible Person means:

A full-time employee of the Employer.

A full-time employee of the Employer who is a member of: _____ (name of union)

Other: A regular, full time active Employee working 40 hours or more hours per week. A person under age 65 who was covered as a retiree under the Employee health benefits plan is effective immediately preceding the Plan Effective date.

Are any classes of employees to be excluded from coverage? Yes No

If yes, please identify the classes and describe the exclusion: _____

2. Employee Definition

Full-Time Employee means:

A person who is regularly scheduled to work a minimum of 40 hours per week and who is on the permanent payroll of the Employer.

Other:

3. The Effective Date of termination for a person who ceases to meet the definition of Eligible Person:

The date such person ceases to meet the definition of Eligible Person.

The last day of the calendar month in which such person ceases to meet the definition of an Eligible Person.

Other: Coverage is terminated for both dental and medical on the final day of the month in which a premium deduction is last withheld, however, retirees are eligible to continue coverage on the medical plan. *Retirees are not eligible for dental coverage unless they elect COBRA.

4. Select an effective date rule for a person who becomes an Eligible Person after the Effective Date of the Employer's health care plan? (The effective date must not be later than the 91st calendar day after the date that a newly eligible person becomes eligible for coverage, unless otherwise permitted applicable by law)

The date of employment.

The day of employment.

The day of the month following month(s) of employment.

The day of the month following days of employment.

The day of the month following the date of employment.

Other: The date of eligibility for coverage is the date of employment for Department Heads and Administrative Staff. Eligibility for non-Department Heads and Admin is the Date they complete 90 days of employment.

Is the waiting period requirement to be waived on initial group enrollment? Yes No

Proprietary and Confidential Information of Claim Administrator

Not for use or disclosure outside Claim Administrator, Employer, their respective affiliated companies and third party representatives, except with written permission of Claim Administrator.

Are there multiple new hire waiting periods? Yes No
If yes, please attach eligibility and contribution details for each section.

5. Domestic Partners covered: Yes No

If yes: a Domestic Partner is eligible to enroll for coverage

If yes, are Domestic Partners eligible for continuation of coverage? Yes No

If yes, are dependents of Domestic Partners eligible to enroll for coverage? Yes No

If yes, are dependents of Domestic Partners eligible for continuation of coverage? Yes No

The Employer is responsible for providing notice of possible tax implications to those Covered Employees with coverage for Domestic Partners.

6. Limiting Age for covered children: Twenty-six (26) years, regardless of presence or absence of a child's financial dependency, residency, student status, employment status, marital status, eligibility for other coverage, or any combination of those factors. Other:

7. Are unmarried step-children under the limiting age eligible for coverage? Yes No

If yes, is residency with the employee required? Yes No

8. Are unmarried grandchildren eligible for coverage?

No Yes (answer the question below)

Must the grandchild be dependent on the employee for federal income tax purposes at the time application is made?

Yes No

9. Termination of coverage upon reaching the Limiting Age:

The last day of coverage is the day prior to the birthday.

The last day of coverage is the last day of the month in which the limiting age is reached.

The last day of coverage is the last day of the billing month.

The last day of coverage is the last day of the year (12/31) in which the limiting age is reached.

The last day of coverage is the day prior to the Employer's Anniversary Date.

Will coverage for a child who is medically certified as disabled and dependent on the employee terminate upon reaching the limiting age even if the child continues to be both disabled and dependent on the employee?

Yes No

However, such coverage shall be extended in accordance with any applicable federal or state law. *The Employer will notify HCSC of such requirements.*

10. Will extension of benefits due to temporary layoff, disability or leave of absence apply?

Yes (specify number of days below) No

Temporary Layoff: days Disability: 6 months days Leave of Absence: 6 months days

However, benefits shall be extended for the duration of an Eligible Person's leave in accordance with any applicable federal or state law. The Employer will notify HCSC of such requirements.

11. Enrollment:

Special Enrollment: An Eligible Person may apply for coverage, Family coverage or add dependents within thirty-one (31) days of a Special Enrollment qualifying event if he/she did not previously apply prior to his/her Eligibility Date or when otherwise eligible to do so. Such person's Coverage Date, Family Coverage Date, and/or dependent's Coverage Date will be the effective date of the qualifying event or, in the event of Special Enrollment due to marriage or termination of previous coverage, then no later than the first day of the Plan Month following the date of receipt of the person's application of coverage.

An Eligible Person may apply for coverage within sixty (60) days of a Special Enrollment qualifying event in the case either of a loss of coverage under Medicaid or a state Children's Health Insurance program, or eligibility for group coverage where the Eligible Person is deemed qualified for assistance under a state Medicaid or CHIP premium assistance program.

Late Enrollment: An Eligible Person may apply for coverage, family coverage or add dependents if he/she did not apply prior to his/her Eligibility Date or did not apply when eligible to do so. Such person's Coverage Date, family

Proprietary and Confidential Information of Claim Administrator

Not for use or disclosure outside Claim Administrator, Employer, their respective affiliated companies and third party representatives, except with written permission of Claim Administrator.

Coverage Date, and/or dependent's Coverage Date will be a date mutually agreed to by the Claim Administrator and the Employer.

Open Enrollment: An Eligible Person may apply for coverage, family coverage or add dependents if he/she did not apply prior to his/her Eligibility Date or did not apply when eligible to do so, during the Employer's Open Enrollment Period. Such person's Coverage Date, family Coverage Date, and/or dependent's Coverage Date will be a date mutually agreed to by the Claim Administrator and the Employer. Such date shall be subsequent to the Open Enrollment Period.

Specify Open Enrollment Period: May/June

- Annual/open enrollment – late applicant may apply during open enrollment
- Annual/open enrollment

12. * Does COBRA Auto Cancel apply? Yes No

Member's COBRA/Continuation of Coverage will be automatically cancelled at the end of the member's eligibility period.

***Not recommended for accounts with automated eligibility*

Lines of Business (Check all applicable services)	<input type="checkbox"/> NO CHANGES <input checked="" type="checkbox"/> See Additional Comments
<p><u>Medical Plan Services:</u></p> <ul style="list-style-type: none"> <input checked="" type="checkbox"/> Blue Choice PPO <input type="checkbox"/> Blue Traditional (In and Out of Network Benefits) <input type="checkbox"/> BlueOptions <input type="checkbox"/> BlueOptions Select PPO <input checked="" type="checkbox"/> Blue Preferred <input type="checkbox"/> Out of Area (Traditional) <p><u>Additional Services:</u></p> <ul style="list-style-type: none"> <input checked="" type="checkbox"/> Blue Care Connection® <input type="checkbox"/> Wellness Incentives <input type="checkbox"/> Well onTarget® <input type="checkbox"/> Blue Directions (Private Exchange) <i>(If selected, the Blue Directions Addendum is attached and made a part of the Agreement.)</i> <input type="checkbox"/> Other Select Product <input type="checkbox"/> Other Select Product <input type="checkbox"/> Other Select Product <input type="checkbox"/> Other Select Product <input type="checkbox"/> Other <input checked="" type="checkbox"/> Other Additional Comments: Terming BVA program 	<p><u>Consumer Driven Health Plan:</u></p> <ul style="list-style-type: none"> <input type="checkbox"/> Blue Edge (HCA) <i>(If selected, complete separate HCA BPA)</i> <input type="checkbox"/> Blue Edge (HSA) (vendor: _____) <input type="checkbox"/> Blue Edge FSA (vendor: ConnectYourCare) <p><u>Prescription Drugs:</u> <i>(If selected, the PBM Fee Schedule Addendum must be attached and is part of this BPA)</i></p> <p>Pharmacy Network:</p> <ul style="list-style-type: none"> <input type="checkbox"/> Traditional Select Network <input checked="" type="checkbox"/> Advantage Network <input type="checkbox"/> Preferred Network <input type="checkbox"/> Elite Network <input type="checkbox"/> Network on PBM Fee Schedule Addendum <p>Drug List: Performance Drug List</p> <p>Other (please specify): _____</p> <p><u>Ancillary Services:</u></p> <ul style="list-style-type: none"> <input checked="" type="checkbox"/> Dental Plan Services <input type="checkbox"/> Vision Plan Services <input checked="" type="checkbox"/> Stop Loss Coverage <i>(if selected, complete separate Exhibit to the Stop Loss Coverage Policy)</i> <input type="checkbox"/> Dearborn National Life Insurance <i>(if selected, complete separate Life application)</i> <input checked="" type="checkbox"/> COBRA Administrative Services <i>(if selected, complete separate COBRA Administrative Services Addendum)</i>

Proprietary and Confidential Information of Claim Administrator
 Not for use or disclosure outside Claim Administrator, Employer, their respective affiliated companies and third party representatives, except with written permission of Claim Administrator.

FEE SCHEDULE

Payment Specifications	<input type="checkbox"/> NO CHANGES	<input type="checkbox"/> SEE ADDITIONAL PROVISIONS
Employer Payment Method: <input type="checkbox"/> Online Bill Pay <input checked="" type="checkbox"/> Electronic <input type="checkbox"/> Auto Debit <input type="checkbox"/> Check		
Employer Payment Period: <input type="checkbox"/> Weekly (cannot be selected if Check is selected as payment method above) <input type="checkbox"/> Semi Monthly <input checked="" type="checkbox"/> Monthly		
Claim Settlement Period: <input checked="" type="checkbox"/> Monthly		
Run-Off Period: Employer payments are to be made for <u>12</u> months following end of Fee Schedule Period. <i>Standard is twelve (12) months.</i>		
Fee Schedule Period: To begin on Effective Date of Coverage and continue for 12 months. If other than 12 months, please specify: 12 Months.		

Administrative Per Employee per Month (PEPM) Charges				
	Medical July 2018	Aug 2018- June 2019	Dental	
Administrative Fee	\$0	\$59.64	\$	\$
Dental	\$	\$	\$ 4.37	\$
Claims Fiduciary	\$	\$	\$	\$
*Rebate Credit for the Prescription Drug Program	\$(0)	\$(21.45)	\$	\$
Commissions	\$	\$	\$	\$
Outpatient Imaging Management Services	\$	\$	\$	\$
Management of the Virtual Visits Program	\$	\$	\$	\$
Other: Select Service Category List Service: _____	\$	\$	\$	\$
Other: Select Service Category List Service: _____	\$	\$	\$	\$
Other: Select Service Category List Service: _____	\$	\$	\$	\$
Miscellaneous: _____	\$	\$	\$	\$
Miscellaneous: _____	\$	\$	\$	\$
Total	\$0	\$38.19	\$4.37	\$

*The Rebate Credit is a per Covered Employee per month credit applied to the monthly billing statement. The Employer and Claim Administrator have agreed to the Rebate Credit and Employer agrees that it and its group health plan have no right to, or legal interest in, any portion of the rebates, either under the pharmacy benefit or the medical benefit, actually provided by the Pharmacy Benefit Manager (PBM) to Claim Administrator and consents to Claim Administrator's retention of all such rebates. The Rebate Credit will be provided from Claim Administrator's own assets and may or may not equal the entire amount of rebates actually provided to Claim Administrator by the PBM or expected to be provided. Rebate Credits shall not continue after termination of the Prescription Drug Program. Employer agrees that any provision in the governing Administrative Services Agreement to the contrary is hereby superseded.

Proprietary and Confidential Information of Claim Administrator

Not for use or disclosure outside Claim Administrator, Employer, their respective affiliated companies and third party representatives, except with written permission of Claim Administrator.

Administrative Line Item Charges	Frequency	Amount
Other: Select Service Category List Service: _____	Select Billing Frequency If applicable, describe other: _____	\$ _____
Other: Select Service Category List Service: _____	Select Billing Frequency If applicable, describe other: _____	\$ _____
Other: Select Service Category List Service: _____	Select Billing Frequency If applicable, describe other: _____	\$ _____
Other: Select Service Category List Service: _____	Select Billing Frequency If applicable, describe other: _____	\$ _____
Miscellaneous: _____	Select Billing Frequency If applicable, describe other: _____	\$ _____
Miscellaneous: _____	Select Billing Frequency If applicable, describe other: _____	\$ _____
Total:		\$ _____

Other Service and/or Program Fee(s) **NO CHANGES** **SEE ADDITIONAL PROVISIONS**

Not applicable to Grandfathered Plans

External Review Coordination: Yes No If yes, coordination fee: \$700 for each external review requested by a Covered Person that the Claim Administrator coordinates for the Employer in relation to the Employer's Plan. Employer elects for external reviews to be performed under the Federal Affordable Care Act external review process.

Reimbursement Service: Yes No

If yes: The Employer has elected to utilize the reimbursement service offered by the Claim Administrator, the Corporate Reimbursement Subrogation department. It is understood and agreed that in the event the Claim Administrator makes a recovery on a third-party liability claim, the Claim Administrator will retain 25% of any recovered amounts other than recovered amounts received as a result of or associated with any Workers' Compensation Law.

Claim Administrator's Third Party Recovery Vendors and Law Firms (other than Reimbursement Services):

Employer will pay no more than 25% of any recovered amount made by Claim Administrator's Third Party Recovery Vendor. Employer will pay no more than 35% of any recovered amount made by Claim Administrator's third party law firm.

Alternative Compensation Arrangements: Employer acknowledges and agrees that Claim Administrator has Alternative Compensation Arrangements with contracted Providers, including but not limited to Accountable Care Organizations and other Value Based Programs. Further information concerning Employer's payment for Covered Services under such Arrangements is described in the Administrative Services Agreement.

Virtual Visits Program: Yes No If yes, Covered Persons would be able to obtain certain Covered Services remotely via video or audio only (where available) capability from Providers participating in the Virtual Visit program.

Termination Administrative Charge

As applies to the Run-Off Period indicated in the Payment Specifications section above:

- i. **For service charges (including, but not limited to, access fees) billed on a per Covered Employee basis at the time of termination of the Agreement or partial termination of Covered Employees,** the Termination Administrative Charge will be the amount equal to ten percent (10%) of the annualized charges based on the service charges in effect as of the termination date or date of partial termination and the Plan participation of the two (2) months immediately preceding the termination date or date of partial termination. Such aggregate amount will be due the Claim Administrator within ten (10) days of the Claim Administrator's notification to the Employer of the Termination Administrative Charge described herein.
- ii. **For service charges (including, but not limited to, access fees) billed on a basis other than per Covered Employee at the time of termination of the Agreement or partial termination of Covered Employees,** the Termination Administrative Charge will be such service charges in effect at the time of termination of the Agreement or partial termination of Covered Employees to be applied and billed by the Claim Administrator, and paid by the

Proprietary and Confidential Information of Claim Administrator

Not for use or disclosure outside Claim Administrator, Employer, their respective affiliated companies and third party representatives, except with written permission of Claim Administrator.

Employer, in the same manner as prior to termination of the Agreement or partial termination of Covered Employees.

The Termination Administrative Charge applicable to the Run-Off Period shall be equal to the sum of the amounts obtained by multiplying the total number of Covered Employees by category (*per Covered Employee per individual or family composite*) during the three (3) months immediately preceding the date of termination by the appropriate factors shown below.

Service				
Medical Run-off Administration Charge:	\$26.72	\$ _____	\$ _____	\$ _____
Dental Run-off Administration Charge	\$ _____	\$ _____	\$ _____	\$ _____
Miscellaneous	\$ _____	\$ _____	\$ _____	\$ _____
Miscellaneous	\$ _____	\$ _____	\$ _____	\$ _____
Total:	\$26.72	\$ _____	\$ _____	\$ _____

Other Provisions

NO CHANGES

SEE ADDITIONAL PROVISIONS

1. Summary of Benefits & Coverage:

a. Will Claim Administrator create Summary of Benefits & Coverage (SBC):

- Yes. Please answer question b. The SBC Addendum is attached.
- No. If No, then skip question b and refer to the Administrative Services Agreement for further information.

b. Will Claim Administrator distribute Summary of Benefits & Coverage (SBC) to participants and beneficiaries?

- No. Claim Administrator will create SBC (only for benefits Claim Administrator administers under the Agreement) and provide SBC to Employer in electronic format. Employer will then distribute SBC to participants and beneficiaries (or hire a third party to distribute) as required by law.
- Yes. Claim Administrator will create SBC (only for benefits Claim Administrator administers under the Agreement) and provide SBC to Employer in electronic format. Employer will then distribute to participants and beneficiaries as required by law, except that Claim Administrator will send the SBC in response to the occasional request received directly from individuals.
- Yes. Claim Administrator will create SBC (only for benefits Claim Administrator administers under the Agreement) and distribute SBC to participants and beneficiaries via regular hardcopy mail or electronically. Distribution Fee for hardcopy mail is \$1.50 per package. The distribution fee will not apply to SBCs that Claim Administrator sends in response to the occasional request received directly from individuals.

2. Does the Employer direct Claim Administrator to provide written statements of creditable coverage to its Covered Employees who reside, or have enrolled dependents who reside, in Massachusetts and file electronic reports to the Massachusetts Department of Revenue in a manner consistent with the requirements under the Massachusetts Health Care Reform Act? Yes No

If no: The Employer acknowledges it will provide written statements and electronic reporting to the Massachusetts Department of Revenue as required by the Massachusetts Health Care Reform Act.

3. Case Management Program: Yes No *The undersigned representative authorizes provision of alternative benefits for services rendered to Covered Persons for Utilization Management, Case Management, and other health care management programs.*

4. Employer acknowledges and agrees to utilize Claim Administrator's standard list of services and supplies for which pre-notification or preauthorization is required: Yes No If no, Employer authorizes Claim Administrator to post Employer's pre-notification or preauthorization requirements on Claim Administrator's Website: Yes No

5. Essential Health Benefits ("EHB") Election:

Employer elects EHBs based on the following:

- 1. EHBs based on a HCSC state benchmark: Illinois Oklahoma Montana Texas New Mexico

Proprietary and Confidential Information of Claim Administrator

Not for use or disclosure outside Claim Administrator, Employer, their respective affiliated companies and third party representatives, except with written permission of Claim Administrator.

2. EHBs based on benchmark of a state other than IL, MT, NM, OK and TX
If so, indicate the state's benchmark that Employer elects: ____

3. Other EHB, as determined by Employer

In the absence of an affirmative selection by Employer of its EHBs, then Employer is deemed to have elected the EHBs based on the Oklahoma benchmark plan.

6. This ASO BPA is binding on both parties and is incorporated into and made a part of the Administrative Services Agreement with both such documents to be referred to collectively as the "Agreement" unless specified otherwise.

7. Producer/Consultant Compensation

The Employer acknowledges that if any producer/consultant acts on its behalf for purposes of purchasing services in connection with the Employer's Plan under the Administrative Services Agreement to which this ASO BPA is attached, the Claim Administrator may pay the Employer's producer/consultant a commission and/or other compensation in connection with such services under the Agreement. If the Employer desires additional information regarding commissions and/or other compensation paid the producer/consultant by the Claim Administrator in connection with services under the Agreement, the Employer should contact its producer/consultant.

Additional Provisions: Mailing and Billing address: 401 W. Owen K. Garriott Rd, Enid OK 73701-5521 for the City of Enid to remain as is. There is no changes needed to the set up of the address structure for this group.

BCBSOK will provide a one-time credit to the Administrative Fee in an amount equal to \$38.19 multiplied by the number of Covered Employees per month (estimated to be approximately \$16,384) for the twelve-month period beginning on the Contract Effective Date. If Employer cancels medical, prescription drug or stop loss coverage prior to the expiration of the policy period, Employer will be responsible for refunding to BCBSOK the full amount of the credit.

Signature

Annie Hickerson

Sales Representative

403 (405) 316-7138

District Phone & FAX Numbers

Producer Representative

Holmes, Murphy & Associates, INC.

Producer Firm

12712 Park Central Drive Suite 100
Dallas, TX 75251

Producer Address

(214) 265-6658

Producer Phone & FAX Numbers

Producer Email Address

420985055

Tax I.D. No.

Signature of Authorized Employer Representative

Print Name

Title

Date

Proprietary and Confidential Information of Claim Administrator

Not for use or disclosure outside Claim Administrator, Employer, their respective affiliated companies and third party representatives, except with written permission of Claim Administrator.

PROXY

The undersigned hereby appoints the Board of Directors of Health Care Service Corporation, a Mutual Legal Reserve Company, or any successor thereof ("HCSC"), with full power of substitution, and such persons as the Board of Directors may designate by resolution, as the undersigned's proxy to act on behalf of the undersigned at all meetings of members of HCSC (and at all meetings of members of any successor of HCSC) and any adjournments thereof, with full power to vote on behalf of the undersigned on all matters that may come before any such meeting and any adjournment thereof. The annual meeting of members shall be held each year in the corporate headquarters on the last Tuesday of October at 12:30 p.m. Special meetings of members may be called pursuant to notice mailed to the member not less than thirty (30) nor more than sixty (60) days prior to such meetings. This proxy shall remain in effect until revoked in writing by the undersigned at least twenty (20) days prior to any meeting of members or by attending and voting in person at any annual or special meeting of members.

From time to time, HCSC pays indemnification or advances expenses to directors, officers, employees or agents consistent with HCSC's bylaws then in force and as otherwise required by applicable law.

Group No.: YN9836, By: _____
DN9836 _____
Print Signer's Name Here
➔ _____
Signature and Title

Group Name: The City of Enid

Address: P.O. Box 1768

City: Enid State: OK ZIP: 73702-
1768

Dated this _____ day of _____
Month Year

Proprietary and Confidential Information of Claim Administrator
Not for use or disclosure outside Claim Administrator, Employer, their respective affiliated companies and third party representatives, except with written permission of Claim Administrator.

EXHIBIT TO THE STOP LOSS COVERAGE POLICY

Employer Group Name: The City of Enid
Employer Group Address: P.O Box 1768
City: Enid **State of Situs:** OK **Zip Code:** 73702-1768
Account Number: YN9836
Employer Group Number(s): YN9836
Current Effective Date of Policy 07/01/2018
Current Policy Period: These specifications are for the Policy Period commencing on 07/01/2018 and ending on 06/31/2019
Claim Administrator: Blue Cross Blue Shield of Oklahoma, a Division of Health Care Service Corporation, a Mutual Legal Reserve Company.

The specifications below shall become effective on the first day of the Policy Period specified above and shall continue in full force and effect until the earliest of the following dates: (1) The last day of the Policy Period; (2) The date the Policy terminates; or (3) The date this Exhibit is superseded in whole or in part by a later executed Exhibit.

A. Aggregate Stop Loss Coverage: Yes No

If yes, complete items 1. through 9. below.

1. New Coverage Renewal of Existing Coverage

2. Stop Loss Coverage during the current Policy Period:

New Coverage (Select one from below):

Incurred and paid during the Policy Period: Claims incurred and paid from 07/01/2018 to 06/31/2019

Incurred with Run-Out: Claims incurred from _____ to _____
and Claims paid from _____ to _____

Run-in coverage: Claims incurred from _____ to _____
and Claims paid from _____ to _____

Renewal of Existing Coverage:

Claim Administrator's Claims: Claims incurred on or after the original Effective Date of Policy and paid during the Policy Period.

Incurred with Run-Out: Claims incurred from _____ to _____
and Claims paid from _____ to _____

3. Aggregate Stop Loss Coverage shall apply to:
- Medical Claims Vision Claims
 - Outpatient Prescription Drug Claims with Company's Pharmacy Benefit Manager
 - Outpatient Prescription Drug Claims with Policyholder's Pharmacy Benefit Manager: _____
 - Dental Claims
 - For Hospital Employer Groups only: *Excludes* _____% of Home Hospital Medical claims
 - Other (please specify): _____

4. Average Claim Value: 911.97 : (per Employee per month)

- Includes Claim Administrator's Provider Access Fee
- Excludes Claim Administrator's Provider Access Fee

Attachment Factor: 125% [110% - 125%] of the Average Claim Value

5. Aggregate Attachment Claim Liability:

- a. Employer's Claim Liability for each Policy Period shall be the sum of the Monthly amounts obtained by multiplying the number of Coverage Units for each Month by the following factor(s):

\$1,139.96 for each Coverage Unit

\$1,139.96 for each Family Coverage Unit

Please use the continuous text field directly below for any other structure (leaving the fields above blank). Note: you can use the "return" key to create additional rows, if needed.

6. Aggregate Stop Loss Coverage includes coverage of Run-Off Paid Claims: Yes No

Run-Off Attachment Claim Liability Factors:

Employer's Run-Off Claim Liability shall be an amount equal to 15% of the annualized Employer Claim Liability based on the participation of the two (2) calendar months immediately preceding termination. Settlement for the final accounting period will be described in the section of the Policy entitled SETTLEMENTS.

7. Aggregate Stop Loss Claims

- a. The amount of Paid Claims during the current Policy Period, less Individual (Specific) Stop Loss Claims if any, that exceed the Aggregate Point of Attachment. The Aggregate Point of Attachment shall equal the sum of the Employer's Claim Liability amounts calculated Monthly as described in item A.5.a. above for the current Policy Period. However, for the current Policy Period the minimum Aggregate Point of Attachment shall be \$5,281,674.
- b. The following applies if the answer to item A.6. above is "Yes." (Aggregate Stop Loss Coverage includes coverage of Run-Off Paid Claims):

In the event of termination at the end of the current Policy Period, Aggregate Stop Loss Coverage shall equal the amount of Final Settlement Paid Claims that exceed the Final Settlement Aggregate Point of Attachment. Final Settlement Paid Claims shall equal the sum of the Paid Claims during the Final Policy Period and the Paid Claims during the Run-Off Period, less Individual (Specific) Stop Loss Claims, if any. The Final Settlement Point of Attachment shall equal the sum of the Employer's Claim Liability amount for the Final Policy Period and the Employer's Run-Off Claim Liability calculated as described in items A.5. and A.6. above. However, for the Final Settlement Period the minimum Aggregate Point of Attachment shall be the minimum Aggregate Point of Attachment in item A.7.a. above increased by 15%.

- c. The amount of "Run-in" Claims that is excluded from Individual (Specific) Stop Loss Coverage in item B.2. is also not eligible for Aggregate Stop Loss Coverage.

8. Stop Loss Premium (Select one):

Annual Premium (Due on the first day of the current Policy Period): \$_____.

The following applies if the answer to item A.6. above is "Yes." (Aggregate Stop Loss Coverage includes coverage of Run-Off Paid Claims): In the event of termination at the end of the current Policy Period, an additional premium amount equal to 15% of the Annual Premium will be due within ten (10) calendar days of receipt of the billing.

Monthly Premium shall be equal to the amounts obtained by multiplying the number of Coverage Units for a particular Month by:

\$5.07 for each Coverage Unit

\$5.07 for each Family Coverage Unit

Please use the continuous text field directly below for any other structure (leaving the fields above blank). Note: you can use the "return" key to create additional rows, if needed.

The following applies if the answer to item A.6. above is "Yes." (Aggregate Stop Loss Coverage includes coverage of Run-Off Paid Claims):

In the event of termination at the end of the current Policy Period, an additional premium amount equal to 15% of the annualized Premium based on the participation of the two (2) months immediately preceding termination will be due within ten (10) calendar days of receipt of the billing.

9. The premium is based upon a current membership of 152 Employee Coverage Units and 277 Family Coverage Units.

B. Individual (Specific) Stop Loss Coverage: Yes No

If yes, complete items 1. through 6. below.

1. New Coverage Renewal of Existing Coverage

2. Stop Loss Coverage during the current Policy Period:

New Coverage (Select one from below):

Incurred and paid during the Policy Period: Claims incurred and paid from 07/01/2018 to 06/31/2019

Incurred with Run-Out: Claims incurred from _____ to _____
and Claims paid from _____ to _____

Run-in coverage: Claims incurred from _____ to _____
and Claims paid from _____ to _____

If coverage is for claims incurred prior to the effective date of the Policy and paid by Policyholder's prior claim administrator, then such claims must be reported by the Policyholder to the Company (Blue Cross and Blue Shield of Oklahoma, a Division of Health Care Service Corporation, a Mutual Legal Reserve Company) and paid by the Policyholder's prior claim administrator by the end of the current Policy Period.

Renewal of Existing Coverage:

Claim Administrator's Claims: Claims incurred on or after the original Effective Date of Policy and paid during the Policy Period.

Incurred with Run-Out: Claims incurred from _____ to _____
and Claims paid from _____ to _____

3. Individual (Specific) Stop Loss Coverage shall apply to:

Medical Claims

Vision Claims

Outpatient Prescription Drug Claims with Company's Pharmacy Benefit Manager

Outpatient Prescription Drug Claims with Policyholder's Pharmacy Benefit Manager: _____

Dental Claims

For Hospital Employer Groups only: Excludes _____% of Home Hospital Medical claims

Other (please specify): _____

4. Individual (Specific) Stop Loss Claims

For each other Covered Person:

a. The amount of Paid Claims during the current Policy Period in excess of the Individual Point of Attachment of \$175,000 per Covered Person. Such amount shall apply for the current Policy Period.

Point of Attachment: Includes Claim Administrator's Provider Access Fee
 Excludes Claim Administrator's Provider Access Fee

b. Employer's Claim Liability equals the sum of Paid Claims for a Covered Person during the current Policy Period up to the Point of Attachment specified in item b.4.a. above.

5. Individual Stop Loss Coverage includes coverage of Run-Off Paid Claims: Yes No

The following applies if the answer to item B.5. above is "Yes" (Individual (Specific) Stop Loss Coverage includes coverage of Run-Off Paid Claims):

a. In the event of termination at the end of the current Policy Period, Individual (Specific) Stop Loss Coverage shall equal the amount of Final Settlement Paid Claims that exceed the Point of Attachment specified in item B.4. above. Final Settlement Paid Claims shall equal the sum of Paid Claims for a Covered Person during the Final Policy Period and the Run-Off Period (beginning on _____ and ending on _____).

b. In the event of termination at the end of the current Policy Period, Employer's Final Settlement Claim Liability equals the sum of Paid Claims for a Covered Person during the Final Policy Period and Run-Off Period up to the Point of Attachment specified in item B.4.a. above.

Settlements for the final accounting period will be described in the section of the Policy entitled SETTLEMENTS.

6. Stop Loss Premium (select one):

Annual Premium (Due on the first day of the current Policy Period): \$_____.

Monthly Premium shall be equal to the amounts obtained by multiplying the number of Coverage Units for a particular Month by:

\$73.59 for each Coverage Unit

\$73.59 for each Family Coverage Unit

The following applies if the answer to item B.5. above is "Yes" (Individual (Specific) Stop Loss Coverage includes coverage of Run-Off Paid Claims): In the event of termination at the end of the current Policy Period, an additional premium amount equal to 20% of the annualized Premium based on the participation of the two (2) months immediately preceding termination will be due within ten (10) calendar days of the billing.

7. The premium is based upon a current membership of 152 Coverage Units and 277 Family Coverage Units.

Additional Provisions:

Retirees Covered: Yes No

The undersigned person represents that he/she is authorized and responsible for purchasing Stop Loss Coverage on behalf of the Employer Group. It is understood that the actual terms and conditions of coverage are those contained in this Exhibit and the Stop Loss Coverage Policy into which this Exhibit shall be incorporated at the time of acceptance by Blue Cross and Blue Shield of Oklahoma, a Division of Health Care Service Corporation, a Mutual Legal Reserve Company ("HCSC"). Upon acceptance, HCSC shall issue a Stop Loss Coverage Policy to the Employer Group. Upon acceptance of this Exhibit and issuance of the Stop Loss Coverage Policy, the Employer shall be referred to as the "Policyholder."

Annie Hickerson

Sales Representative

Signature of Authorized Purchaser

Ribar Said

Name of Underwriter

Title of Authorized Purchaser

Date

INTERNAL USE ONLY	Date Exhibit approved by Underwriting: Name of Underwriter:
-------------------	----------------------------------------------------------------

City Commission Meeting

7.6.

Meeting Date: 06/19/2018

Submitted By: Jacqueline Cook, Engineering EA

SUBJECT:

ACCEPT PUBLIC HIGHWAY EASEMENT FROM EDUARDO ARMAS AND MEGAIN ARMAS, GARFIELD COUNTY, OKLAHOMA, AND AUTHORIZE PAYMENT FOR RIGHT OF WAY ON CLEVELAND STREET AT BURLINGTON NORTHERN SANTA FE (BNSF) RAIL ROAD, IN THE AMOUNT OF \$9,030.00.

BACKGROUND:

The City needs to acquire a 70 foot wide right of way on the East side of Cleveland Street just South of the Burlington Northern Santa Fe Railroad tracks. Eduardo and Megain Armas are the property owners of this piece of needed right of way.

Payment amount is based on the established per square foot price that has been paid for all right of way acquisition on the Cleveland Street project.

RECOMMENDATION:

Accept Public Highway Easement and authorize payment.

PRESENTER:

Robert Hitt, P.E., City Engineer

Fiscal Impact

Budgeted Y/N: Y

Amount: \$9,030.00

Funding Source:

Capital Improvement Fund

City Commission Meeting

7.7.

Meeting Date: 06/19/2018

Submitted By: Jacqueline Cook, Engineering EA

SUBJECT:

APPROVE CHANGE ORDER NO. 1 WITH LUCKINBILL, INC., ENID, OKLAHOMA, FOR THE 1900 BLOCK OF EAST BROADWAY AVENUE, BOX CULVERT REPLACEMENT PROJECT NO. F-1703C, IN THE AMOUNT OF \$3,935.88.

BACKGROUND:

This project replaced the concrete structure along Phillips Tributary at the 1900 block of East Broadway in the City of Enid. The work of removing the existing box culvert and construction of a new reinforced concrete box has been completed. The final inspection of the work revealed a need to add additional erosion control and sloped pavement.

This change order is presented to raise the southeast wing wall and add riprap and sloped pavement for protection at the southeast, southwest, and northwest corners of the box culvert.

The original contract amount was \$317,631.90, with this change order, the new amount will be \$321,567.78.

RECOMMENDATION:

Approve Change Order No. 1 in the amount of \$3,935.88.

PRESENTER:

Robert Hitt, P.E., City Engineer

Fiscal Impact

Budgeted Y/N: Y

Amount: \$3,935.88

Funding Source:

Storm Water Fund

City Commission Meeting

7.8.

Meeting Date: 06/19/2018

Submitted By: Jacqueline Cook, Engineering EA

SUBJECT:

AWARD A CONTRACT TO LUCKINBILL, INC., ENID, OKLAHOMA FOR THE 2018 SANITARY SEWER VIDEO INSPECTIONS PROJECT NO. S-1801B, IN THE AMOUNT OF \$244,148.32, AND AUTHORIZE THE MAYOR TO EXECUTE ALL CONTRACT DOCUMENTS.

BACKGROUND:

This project provides for video inspection of approximately 163,000 linear feet of sanitary sewer lines, which will identify defects in the pipe system for future point repairs. The work is part of the Sanitary Sewer Overflow reduction program that is a requirement to meet our ODEQ discharge permit.

One bid was received as follows:

Luckinbill Inc.	\$244,148.32
-----------------	--------------

RECOMMENDATION:

Award contract to Luckinbill Inc. in the amount of \$244,148.32 and authorize the Mayor to execute all contract documents.

PRESENTER:

Kamalakar Maraboyina, Project Engineer.

Fiscal Impact

Budgeted Y/N: Y

Amount: \$300,000

Funding Source:

Sanitary Sewer Capital Improvement Fund

Attachments

Canvass S-1808B

FROM: Kamalakar Maraboyina
DATE: June 19, 2018

PAGE 1 OF 1

CANVASS OF BIDS
for
2018 Sanitary Sewer Video Inspections
Project Number S-1801B

<u>FIRM NAME AND ADDRESS</u>	<u>PRODUCT/SERVICE BID</u>	<u>PRICE</u>
Luckinbill, Inc. P.O. Box 186 Enid, OK 73702	Base Bid	\$ 244,148.32

Bid meets or exceeds all major specifications: X YES NO
Bid meets or exceeds all minor specifications: X YES NO

DEVIATIONS: **Met the Specifications.**

RECOMMENDATION: Award contract to Luckinbill, Inc., in the amount of
\$ 244,148.32

City Commission Meeting

7.9.

Meeting Date: 06/19/2018

Submitted By: Korina Crawford, Executive Assistant

SUBJECT:

APPROVE GROUND WATER LEASE BETWEEN WILLOW LAKE OWNERS ASSOCIATION AND THE CITY OF ENID.

BACKGROUND:

Willow Lake Subdivision has groundwater wells that are used to fill the lakes that are a well known feature for the subdivision. However, Willow Lake Subdivision does not have enough acreage under the subdivision to allow for the refilling and maintenance of the lakes. The Association has asked the City of Enid if it could obtain an OWRB permit to pump sufficient ground water to lease some water rights in the Enid Isolated Terrace associated with City of Enid owned property that have no water wells in use and for which the City has no plans to place wells on. The lease provides a \$1,000.00 lease payment a year. The Association will not place wells on the City property but will use the water rights leased to increase the amount of water it can pump annually from the Willow Lake Subdivision wells. OWRB staff has reviewed the draft lease and indicates that OWRB finds the resolution of the issue appropriate.

RECOMMENDATION:

Approve the lease.

PRESENTER:

Carol Lahman, City Attorney.

Attachments

Willow Lake Groundwater Contract

LEASE OF GROUNDWATER

This Groundwater Lease (the "Lease") is by and between Willow Lake Owners Association, ("Lessee") and the City of Enid, Enid, Oklahoma ("Lessor").

RECITALS

WHEREAS, Lessor owns real property that underlies the Enid Isolated Terrace Aquifer in Garfield County, Oklahoma, more specifically described as follows:

1. The West half of the Southwest Quarter of Section 18, T22N, R5W, WIM (80 acres);
2. Unplatted Real Estate all of South of Railroad Right of Way in NE Quarter Section 13, T22, R6W; (82.8 acres), and,
3. The Southeast Quarter of Section 13, T22, 6R (the portion that underlies the Enid Isolated Terrace) (approximately 150 acres); and (hereinafter the "Subject Property").

WHEREAS, the Lessor has no groundwater wells on the Subject Property;

WHEREAS, the City of Enid through its Mayor and Board of Commissioners has determined that the use of the water rights attributable to the Subject Property by the Lessee for the maintenance and preservation of the ponds within the Willow Lake Subdivision is for a beneficial purpose to insure the water does not grow stagnate and risk the health of residents;

WHEREAS, Lessor desires to lease to Lessee a 312.8 acres of water rights that underlie the Subject Property, subject to the terms of this Lease, and Lessee desires to lease such groundwater pursuant to such terms;

NOW THEREFORE, in consideration of the mutual promises and covenants in this Lease, the receipt and sufficiency of which are hereby acknowledged, Lessor and Lessee agree as follows:

1. **Water Rights.**

- a. Lessor leases to Lessee the Lessor's groundwater rights to the Subject Property an area equal to approximately 312.8 acres more specifically described above, to allow Lessee withdraw up to 156 acre-feet of groundwater annually in accordance with OWRB rules.
- b. Lessor and Lessee will jointly execute any required OWRB forms to allow Lessee to utilize the groundwater rights attributable to the Subject Property as part of Lessee's Permit to use groundwater for irrigation and other private lake purposes. Lessor and Lessee agree that, at the termination of the subject lease of water rights at the end of the initial term and extensions thereof, the Lessee agrees to execute a joint Transfer of Ownership to re-convey to Lessor, Lessee's rights, title, and interest in any Permit it obtains from OWRB for the Subject

Property within 10 days of the occurrence of the subject terminating event, provided that well locations in the Permit shall be retained and not be transferred to Lessor.

2. Additional Lease Rights and Limitations.

- a. The lease of the Water Rights as defined above shall also include the right to withdraw and beneficially use the water related to or pertaining to the Water Rights.
- b. Notwithstanding anything to the contrary in this Lease, nothing in this Lease allows Lessee to use any existing well, if any, on any portion of the subject property.
- c. Notwithstanding anything to the contrary in this Lease, nothing in this Lease allows Lessee to use more than the 160 acre-feet of groundwater annually attributable to the Subject Property.

3. Term.

- a. The initial term of this Lease shall commence on the day that the OWRB provides approval for the Lessee to use the 156 acre feet of water attributable under the Subject Property (“Commencement Date”) and shall expire on the day that is seven years after the Commencement Date (the “Initial Term”).
- b. Willow Lake has the option to extend the Initial Term by three (3) years (the “Renewal Term”) from the Initial Term expiration date by giving notice to Lessor not less than six (6) months prior to the expiration of the Initial Term.
- c. In the unlikely event that the Lessor has a need to use the water rights for serving the City of Enid, all rights under this lease shall revert to the Lessor after 120 days written notice to Lessee. Payment of rent shall be prorated to the date of reversion.

4. Payment.

- a. For the Initial Term, Lessee agrees to pay an annual rent of \$1,000.00, payable in annual installments, due on the 10th of the month beginning with the month immediately after the month that the OWRB provides approval of the use of the 160 acre feet of water rights under the Subject Property by the Lessee. For the Renewal Term, Lessee agrees to pay annual rent of \$1,000.00, adjusted annually for inflation according to the Consumer Price Index for All Urban Consumers, Midwest urban Size D, U.S. City Average All Items (1982-84 = 100) starting with the index for the last year of the Initial Term.

5. Fees; Taxes. Lessee agrees to pay all fees, costs, and charges, including attorney's

fees, associated with:

- a. the transfer and partition of the Permit from Lessor to Lessee so as to accomplish the intent and purpose of this Lease;
 - b. any county or other recordation fees deemed necessary by either of Lessor or Lessee; and,
 - c. any fees or costs charged by any other regulatory agency having jurisdiction over the Permit and/or the rights granted by the Permit. Lessee shall not be liable for any fees, taxes, or assessments on the Property itself.
6. **Permit Maintenance.** Lessee agrees, at its own cost and expense, to undertake to perform any necessary activities to maintain and keep its Permit valid and in good standing in accordance with the OWRB regulations and requirements. Lessee further agrees to follow all OWRB rules related to the legal use of its Permit.
7. **Assignability.** Neither party shall assign this Lease or any of its rights and obligations hereunder without the consent of the other party to this lease.
8. **Default.** If for any reason Lessee fails to comply with any provision of this Lease and such failure continues for a period of thirty (30) days after receiving written notice of such failure from Lessor, Lessor may, at its election, exercise all rights which may be available to it in law or in equity, including termination of the Lease. If Lessor fails to comply with any provision of the Lease and such failure continues for a period of thirty (30) days after receiving written notice of such failure from Lessee, Lessee may, at its election, exercise all rights which may be available to it in law or in equity, including termination of the Lease.
9. **Waiver.** The failure on the part of either party to require the performance by the other of any portion of this Lease shall not be deemed a waiver of, or in any way affect the party's right to enforce, such provision. Any waiver by either party of any provision of this Lease shall not be a waiver of any other provision of this Lease.
10. **Severability.** If, by the operation of law, any provision of this Lease becomes unenforceable or invalid, the remaining terms of this Lease will remain in full force and effect, and the parties agree that the validity of the Lease as a whole shall not be affected.
11. **Governing Law, Forum.** This Lease is governed by the laws of the State of Oklahoma and is performable in Garfield County. Any action related to this Lease or the rights and obligations to be performed under this Lease must be brought only in state court situated in Garfield County, Oklahoma.
12. **Entire Agreement.** This Lease contains all agreements between the Lessee and the Lessor. Any agreement not contained in this Lease shall not be recognized by

the Lessee and the Lessor. This Lease superseded all prior and contemporaneous agreements between the Lessee and the Lessor, whether verbal or written.

13. **Further Assurances.** Each party, upon receipt of notice from the other party, shall sign (or cause to be signed) all further documents, do (or cause to be done) all further acts, and provide all assurances as may reasonably be necessary or desirable to give effect to the terms of this Lease.
14. **Counterparts.** This Lease may be executed by the parties in multiple counterparts, each of which, when executed and delivered, is deemed an original instrument. All counterparts together shall constitute one and the same instrument.

AGREED AND APPROVED by the Mayor and Board of Commissioners of the City of Enid, Oklahoma, on this _____ day of June, 2018.

LESSOR

City of Enid, Oklahoma

By: _____
William E. Shewey, Mayor

LESSEE
Willow Lake Owners Association

By: _____
Name: John Greven
Title: President

EXHIBIT 1

LEGAL DESCRIPTION OF GROUNDWATER INTEREST

Lessor owns real property that underlies the Enid Isolated Terrace Aquifer in Garfield County, Oklahoma, more specifically described as follows:

4. The West half of the Southwest Quarter of Section 18, T22N, R5W, WIM (80 acres);
5. Unplatted Real Estate all of South of Railroad Right of Way in NE Quarter Section 13, T22, R6W; (82.8 acres), and ,
6. The Southeast Quarter of Section 13, T22, 6R (the portion that underlies the Enid Isolated Terrace) (approximately 150 acres); and (hereinafter the “Subject Property”).

totaling approximately 312.8 acres.

City Commission Meeting

10.1.

Meeting Date: 06/19/2018

Submitted By: Erin Crawford, Chief Financial Officer

SUBJECT:

CONSIDER A RESOLUTION INCREASING THE 2017-2018 FISCAL FINANCIAL PLAN FOR THE ENID MUNICIPAL AUTHORITY IN THE AMOUNT OF \$150,000.00.

BACKGROUND:

Stormwater revenues are projected to come in approximately \$150,000.00 or 9.1% higher than budgeted for the 2017-2018 fiscal year. The appropriations in the Enid Municipal Authority Operations Department must be increased to transfer out the associated revenues to the Stormwater Fund. Funds are available to appropriate from current year Stormwater fees collected.

RECOMMENDATION:

Approve resolution.

PRESENTER:

Erin Crawford, Chief Financial Officer.

Fiscal Impact

Budgeted Y/N: N
Amount: \$150,000.00
Funding Source:
Stormwater Revenues

Attachments

Resolution

RESOLUTION

A RESOLUTION INCREASING THE 2017-2018 FISCAL FINANCIAL PLAN FOR THE ENID MUNICIPAL AUTHORITY IN THE AMOUNT OF \$150,000.00.

WHEREAS, stormwater revenues are projected to be approximately 9.1% higher than budgeted for fiscal year 2017-2018; and

WHEREAS, the appropriated amounts for the 2017-2018 Enid Municipal Authority Operations Department in the Enid Municipal Authority Fund must be increased by an additional \$150,000.00 to transfer stormwater revenues to the Stormwater Fund; and

WHEREAS, stormwater revenues collected during the 2017-2018 fiscal year are available to be transferred from the Enid Municipal Authority to the Stormwater Fund;

AND NOW, THEREFORE, BE IT RESOLVED BY THE CHAIRMAN AND BOARD OF TRUSTEES OF THE ENID MUNICIPAL AUTHORITY THAT THE AUTHORITY'S 2017-2018 FISCAL FINANCIAL PLAN BE AMENDED TO INCREASE THE ENID MUNICIPAL AUTHORITY OPERATIONS DEPARTMENT LISTED BELOW:

FUND 31 ENID MUNICIPAL AUTHORITY	
Operations 31-315-4710	\$150,000.00

Adopted this 19th day of June 2018.

Chairman

(Seal)

ATTEST:

Secretary

City Commission Meeting

10.2.

Meeting Date: 06/19/2018

Submitted By: Korina Crawford, Executive Assistant

SUBJECT:

AUTHORIZE PAYMENTS TO CIMARRON TERRACE WATER ASSOCIATION FOR UNDER PRODUCTION OF UNIT 4 AND UNIT 6 IN AMES WATER FIELD FOR 2013 THROUGH 2017.

BACKGROUND:

Two wells in the Ames water field (Ames Well #12 and Ames Well #16) have different minimum production than the other royalty wells within the Cimarron Terrace Water Association. These two wells have minimums that are tied to the production capacity of the wells. The other wells in the Association have a dollar amount listed in the leases. The surface owners made a request that the EMA review the production to determine whether the payments matched the minimums. Staff reviewed the current pumping capacity of the two wells and has determined that for Ames #12 in Unit 4, EMA owes \$19,644.90 for 2013-2017 and for Ames #16 in Unit 6; EMA owes \$25,238.27 for 2013-2017.

RECOMMENDATION:

Authorize Payment of \$19,644.90 for Unit 4 to Cimarron Terrace Water Association and payment of \$25,238.27 for Unit 6 to Cimarron Terrace Water Association.

PRESENTER:

Carol Lahman, City Attorney.

City Commission Meeting

10.3.

Meeting Date: 06/19/2018

Submitted By: Alissa Lack, City Clerk

SUBJECT:

CONSIDER AND TAKE ACTION WITH RESPECT TO A RESOLUTION AGREEING TO FILE APPLICATION(S) WITH THE OKLAHOMA WATER RESOURCES BOARD (THE "OWRB") FOR FINANCIAL ASSISTANCE THROUGH OWRB FINANCIAL ASSISTANCE PROGRAM AND THROUGH THE DRINKING WATER STATE REVOLVING FUND LOAN PROGRAM, WITH THE LOAN PROCEEDS BEING FOR THE PURPOSE OF FINANCING CERTAIN WATER SYSTEM IMPROVEMENTS; AND CONTAINING OTHER PROVISIONS RELATED THERETO.

BACKGROUND:

This item takes action for financial assistance from OWRB for the purpose of financing certain water system improvements for the Kaw Lake Pipeline Project.

RECOMMENDATION:

Consider resolution.

PRESENTER:

Allan Brooks, Public Finance Law Group, LLC Attorney.

Attachments

Resolution

THE BOARD OF TRUSTEES OF THE ENID MUNICIPAL AUTHORITY, GARFIELD COUNTY, OKLAHOMA, MET IN REGULAR SESSION ON THE 19TH DAY OF JUNE, 2018, AT 6:30 O'CLOCK P.M.

PRESENT:

ABSENT:

(Other Proceedings)

THEREUPON, the Chairman introduced a Resolution which was read in full and upon motion by Trustee _____, seconded by Trustee _____, said Resolution was adopted by the following vote:

AYE:

NAY:

Said Resolution was thereupon signed by the Chairman of the Authority, attested by the Secretary of the Authority, sealed with the seal of said Authority and is as follows:

RESOLUTION

A RESOLUTION AGREEING TO FILE APPLICATION(S) WITH THE OKLAHOMA WATER RESOURCES BOARD (THE "OWRB") FOR FINANCIAL ASSISTANCE THROUGH OWRB FINANCIAL ASSISTANCE PROGRAM AND THROUGH THE DRINKING WATER STATE REVOLVING FUND LOAN PROGRAM, WITH THE LOAN PROCEEDS BEING FOR THE PURPOSE OF FINANCING CERTAIN WATER SYSTEM IMPROVEMENTS; AND CONTAINING OTHER PROVISIONS RELATED THERETO.

WHEREAS, the Enid Municipal Authority, Garfield County, Oklahoma (the "Authority") has under consideration the financing of certain capital expenditures pertaining to water system improvements related or incidental to the construction of a water transmission pipeline from Kaw Lake to Enid and related water treatment, storage, and distribution facilities (collectively, the "Project"); and

WHEREAS, it is deemed desirable for the Authority to give preliminary authorization for the issuance of obligations for such purpose; and

WHEREAS, the Oklahoma Water Resources Board has made monies available to qualified entities for the financing or refinancing of certain qualifying projects; and

WHEREAS, the Authority hereby agrees to file an application(s) with the Oklahoma Water Resources Board for financial assistance in the aggregate amount as will be sufficient to pay certain costs associated with the referenced Project.

BE IT RESOLVED BY THE BOARD OF TRUSTEES OF THE ENID MUNICIPAL AUTHORITY, GARFIELD COUNTY, OKLAHOMA:

Section 1. Application. The Authority shall file an Application(s) with the Oklahoma Water Resources Board seeking financial assistance through the OWRB Financial Assistance Program and through the OWRB Drinking Water State Revolving Fund Loan Program; and the Chairman or Vice Chairman and Secretary or Assistant Secretary of the Authority are hereby authorized to execute said Application(s) for and on behalf of the Authority. The Authority is further authorized to advance to the Oklahoma Water Resources Board the necessary application fees in connection with the referenced Application(s).

Section 2. Other Matters. The Chairman or Vice Chairman and Secretary or Assistant Secretary of the Authority are hereby authorized and directed to do all other lawful things necessary to carry out the terms and conditions of this Resolution.

[Remainder of Page Left Blank Intentionally]

PASSED AND APPROVED THIS 19TH DAY OF JUNE, 2018.

ENID MUNICIPAL AUTHORITY

By _____
Chairman

ATTEST:

By _____
Secretary

(SEAL)

STATE OF OKLAHOMA)
)SS
COUNTY OF GARFIELD)

I, the undersigned, the duly qualified and acting Secretary of the Enid Municipal Authority, Garfield County, Oklahoma, hereby certify that the above and foregoing is a true, correct and complete copy of a Resolution duly adopted by the Board of Trustees of said Authority and of the proceedings of said Authority in the adoption of said Resolution as shown by the records of my office. I further certify that said meeting complied in all respects with the "Open Meeting Law".

GIVEN UNDER MY HAND THIS 19TH DAY OF JUNE, 2018.

(SEAL)

Secretary

Meeting Date: 06/19/2018

Submitted By: Korina Crawford, Executive Assistant

SUBJECT:

CONSIDER CONVENING INTO EXECUTIVE SESSION TO DISCUSS AN ECONOMIC DEVELOPMENT PROPOSAL INVOLVING THE CITY'S WASTEWATER TREATMENT PLANT; AND TO DISCUSS NEGOTIATIONS WITH ENID/GARFIELD COUNTY FRATERNAL ORDER OF POLICE LODGE #144 AND AMERICAN FEDERATION OF STATE, COUNTY AND MUNICIPAL EMPLOYEES (AFSCME) LOCAL #1136; AND TO DETERMINE WHETHER TO JOIN IN RE: NATIONAL PRESCRIPTION OPIATE LITIGATION, AND TO DISCUSS CITY OF ENID V. FREDDIE AND MARY KATHRYN LORENZ, 2013-49, AND RECONVENE INTO REGULAR SESSION TO TAKE ANY NECESSARY ACTION.

BACKGROUND:

The City Attorney recommends that the Mayor and Board of Commissioners go into Executive Session pursuant to 25 O.S. 307(C)(10), economic development proposal, 307 (B)(2), negotiations with representatives of employee groups, and 307(B)(4) pending litigation and the attorney-client privilege, to engage in confidential communication between the public body and its attorney concerning these matters since disclosure would seriously impair the ability of the public body to act and proceed with them appropriately.

RECOMMENDATION:

Consider going into executive session.

PRESENTER:

Carol Lahman, City Attorney.
