



City of Enid  
401 W. Owen K. Garriott Road  
Enid, Oklahoma 73702  
580-234-0400

---

---

BOARD OF COMMISSIONERS

---

---

**NOTICE OF REGULAR MEETING**

Mayor and Board of Commissioners of the City of Enid, Oklahoma, the Trustees of the Enid Municipal Authority, a Public Trust, and the Trustees of the Enid Economic Development Authority, a Public Trust

Notice is hereby given that the Mayor and Board of Commissioners of the City of Enid, Oklahoma, the Trustees of the Enid Municipal Authority, a Public Trust, and the Trustees of the Enid Economic Development Authority, a Public Trust, will meet in a regular session at 6:30 p.m. on the 18th day of November, 2014, in the Council Chambers of the City Administration Building, located at 401 W. Owen K. Garriott Road in said city, and the agenda for said meeting is as follows:

- AGENDA -

MAYOR AND BOARD OF COMMISSIONERS REGULAR MEETING

1. CALL TO ORDER/ROLL CALL.
2. INVOCATION.
3. FLAG SALUTE.
4. CONSIDER APPROVAL OF MINUTES OF THE REGULAR COMMISSION MEETING OF NOVEMBER 4, 2014.
5. AWARDS, PRESENTATIONS, AND ORGANIZATIONAL BUSINESS.
  - 5.1 PRESENT PET AVAILABLE FOR ADOPTION AT THE CITY ANIMAL SHELTER.
  - 5.2 PRESENTATION TO FORMER COMMISSIONER MIKE STUBER.
6. HEARINGS.

6.1 NONE.

7. COMMUNITY DEVELOPMENT.

7.1 NONE

8. ADMINISTRATION.

8.1 AN ORDINANCE AMENDING THE ENID MUNICIPAL CODE, 2014, TITLE 9, ENTITLED "BUILDING REGULATIONS," CHAPTER 4, ENTITLED "ELECTRICAL CODE," SECTION 9-4-3, ENTITLED "AMENDMENTS TO ELECTRICAL CODE" TO AMEND THE QUALIFICATIONS FOR ELECTRICAL INSPECTOR AND CORRECT GRAMMATICAL ERRORS; PROVIDING FOR REPEALER, SAVINGS CLAUSE, SEVERABILITY AND CODIFICATION.

**BACKGROUND:** This ordinance was reviewed by the Commission at the November 4, 2014, Study Session. This amendment is intended to mirror the State's minimum requirements for Electrical Inspector to the requirements of State law.

**BUDGETED ITEM:** Not Applicable.

**FUNDING SOURCE:** Not Applicable.

**ATTACHMENTS:** Ordinance.

**RECOMMENDATION:** Approve and execute Ordinance.

**PRESENTER:** Andrea L. Chism, City Attorney.

8.2 CONSIDER A RESOLUTION AUTHORIZING THE CITY ATTORNEY TO LEVY AGAINST THE TAX ROLLS A JUDGMENT OF THE WORKERS' COMPENSATION COURT OF THE STATE OF OKLAHOMA, ENTERED IN FAVOR OF RICHARD L. WALLACE IN THE AMOUNT OF \$36,000.00; APPROVING AN AGREEMENT ACKNOWLEDGING SUCH JUDGMENT, PROVIDING FOR THE PAYMENT OF SUCH JUDGMENT IN EXCHANGE FOR THE CITY'S PROMISE TO REPAY SUCH JUDGMENT FROM COLLECTED TAX LEVIES.

**BACKGROUND:** This is a companion to item 12.2. Richard L. Wallace is a Heavy Equipment Operator for the City of Enid. On February 27, 2013, he injured his right arm when he slipped while entering a bull dozer. He hung from his right arm, fracturing the end of the humerus bone, which subsequently resulted in surgery on his shoulder. The City admitted injuries to Mr. Wallace's arm. A settlement was approved by

the Worker's Compensation Court on October 22, 2014, and Mr. Wallace was awarded \$36,000.00.00. This item levies the judgment.

**BUDGETED ITEM:** No.

**FUNDING SOURCE:** Tax Rolls.

**ATTACHMENTS:** Resolution and Acknowledgment of Judgment.

**RECOMMENDATION:** Approve Resolution and Agreement.

**PRESENTER:** Andrea L. Chism, City Attorney.

- 8.3 AN ORDINANCE AMENDING THE ENID MUNICIPAL CODE, 2014, TITLE 10, ENTITLED "PLANNING AND DEVELOPMENT," CHAPTER 4 ENTITLED "CAPITAL IMPROVEMENT AND RECOVERY," SECTION 10-4-3 TO IDENTIFY THE NEW LOCATION OF SIDEWALK REGULATIONS AND CORRECT GRAMMATICAL ERRORS; CREATING TITLE 10, ENTITLED "CAPITAL IMPROVEMENT AND RECOVERY," CHAPTER 6, ENTITLED "SIDEWALKS," SECTIONS 10-6-1 AND 10-6-2 TO RELOCATE SIDEWALK REGULATIONS AND EXPAND THE REQUIREMENT TO PROVIDE SIDEWALKS TO ALL DEVELOPMENTS AND REDEVELOPMENTS; AMENDING TITLE 12, ENTITLED "SUBDIVISIONS," CHAPTER 6, ENTITLED "SUBDIVISION DESIGN STANDARDS," SECTION 12-6-2, ENTITLED "STREET," TO RELOCATE SIDEWALK REGULATIONS AND CORRECT GRAMMATICAL ERRORS; AMENDING TITLE 12, ENTITLED "SUBDIVISIONS," CHAPTER 8, ENTITLED "CONSTRUCTION PLANS AND SPECIFICATION," SECTION 12-8-7, ENTITLED "SIDEWALK CONSTRUCTION PLANS," TO UPDATE SIDEWALK SPECIFICATIONS IN ACCORDANCE WITH FEDERAL LAWS AND REGULATIONS AND CORRECT GRAMMATICAL ERRORS; PROVIDING FOR REPEALER, SAVINGS CLAUSE, SEVERABILITY, AND CODIFICATION.

**BACKGROUND:** This ordinance was reviewed by the Commission at the November 4, 2014, Study Session. This amendment is intended to expand the requirement for developers to provide sidewalks in all developments, update sidewalk specifications pursuant to federal laws and regulations and correct grammatical errors.

**BUDGETED ITEM:** Not Applicable.

**FUNDING SOURCE:** Not Applicable.

**ATTACHMENTS:** Ordinance.

**RECOMMENDATION:** Approve and execute Ordinance.

**PRESENTER:** Shandi Campbell, Assistant City Attorney.

**8.4 CONVEYANCE OF UTILITY EASEMENTS TO OKLAHOMA GAS & ELECTRIC COMPANY TO FACILITATE POWER FEEDS TO RE-LOCATED NAVIGATIONAL EQUIPMENT IN CONJUNCTION WITH THE RUNWAY 17/35 EXTENSION PROJECT AT ENID WOODRING REGIONAL AIRPORT.**

**BACKGROUND:** The extension of Runway 17/35 to the south required that underground power lines will need to be re-routed to accommodate the re-located navigation equipment. Therefore new easements need to be granted to facilitate the installation of these power lines. All of these proposed easements are on airport property and will not interfere with existing or anticipated future improvements or operations of the Airport.

**BUDGETED ITEM:** Not Applicable.

**FUNDING SOURCE:** Not Applicable.

**ATTACHMENTS:** Location map, easement agreement

**RECOMMENDATION:** Convey easement.

**PRESENTER:** Dan Ohnesorge, Airport Director.

**8.5 A RESOLUTION CANVASSING RETURNS OF THE SPECIAL ELECTION HELD IN THE CITY OF ENID, OKLAHOMA, ON NOVEMBER 4, 2014, ON ORDINANCE NO. 2014-29, GRANTING TO ONE GAS, INC., A FRANCHISE FOR A PERIOD OF TWENTY-FIVE YEARS.**

**BACKGROUND:** On November 4, 2014, the voters of the City of Enid passed City of Enid Ordinance No. 2014-29, granting a 25-year franchise to One Gas, Inc. The ordinance requires the Commission to canvass the returns and submit a written declaration to One Gas, Inc. Upon receipt, One Gas, Inc. shall have 30 days to accept the franchise, at which time it will become operative.

**BUDGETED ITEM:** N/A.

**FUNDING SOURCE:** N/A.

**ATTACHMENTS:** Ordinance.

**RECOMMENDATION:** Approve resolution.

**PRESENTER:** Andrea L. Chism, City Attorney.

9. CONSENT.

- 9.1 AWARD A CONTRACT TO DERWIN'S CONSTRUCTION, LLC, ENID OKLAHOMA, FOR THE 2015 CONCRETE REPAIR PROGRAM, PROJECT NO. R-1505A, AND AUTHORIZE THE MAYOR TO EXECUTE ALL CONTRACT DOCUMENTS AFTER REVIEW BY THE CITY ATTORNEY.

**BACKGROUND:** This project will provide repair of streets, sidewalks, drives, curbs, and gutters after concrete is excavated for water line repairs. This project funds labor only for concrete repairs, the City of Enid will provide all required materials.

Derwin's Construction submitted the sole bid for this project with the following detailed items:

Bid Items	Project Estimate	Bid
1,000 Linear Feet Curb and Gutter	\$16,000.00	\$15,000.00
1,000 Square Yards Sidewalk	\$22,400.00	\$22,500.00
2,400 Square Yards Concrete	\$111,600.00	\$108,000.00
Total	\$150,000.00	\$145,500.00

The Derwin's Construction submittal was determined to be a responsible and responsive bid and is 3% below project estimates.

**BUDGETED ITEM:** Yes.

**FUNDING SOURCE:** Street & Alley.

**ATTACHMENTS:** Canvass of bids.

**RECOMMENDATION:** Award contract to Derwin's Construction, LLC and authorize the Mayor to execute all contract documents after review by the City Attorney.

**PRESENTER:** James Neal, Deputy Director of Public Works.

- 9.2 ACCEPT THE PEDESTRIAN SIGNAL TRAIL CROSSING PROJECT AT U.S. 81 AND FRANTZ STREET WITH TRAFFIC SIGNALS, INC., EDMOND, OKLAHOMA, PROJECT NO. M-1401A.

**BACKGROUND:** This project provided a pedestrian-controlled traffic signal at the Van Buren Street (U.S. 81) and Frantz Avenue pedestrian trail crossing intersection.

The total contract amount of the project was \$57,602.28.

The contractor has completed all work and the project is presented for acceptance. There is a three-year Maintenance Bond on this project.

**BUDGETED ITEM:** Yes.

**FUNDING SOURCE:** Capital Improvement Fund.

**ATTACHMENTS:** None.

**RECOMMENDATION:** Accept project.

**PRESENTER:** Murali Katta, P.E., Project Engineer.

**9.3 APPROVE CHANGE ORDER NO. 1 WITH DUKE'S ROOT CONTROL, INC., SYRACUSE, NEW YORK, ON THE 2014 SANITARY SEWER CHEMICAL ROOT CONTROL PROJECT, PROJECT NO. S-1402C.**

**BACKGROUND:** This work covers chemically treating sanitary sewer lines to eliminate root intrusion.

This change order allows for continuing the work of protecting the sanitary sewer from overflows in a timely manner and at a competitive cost.

Change Order No. 1 will add \$125,000.00, based on unit prices, to the original contract amount, bringing the total contract amount to \$193,949.36.

**BUDGETED ITEM:** Yes.

**FUNDING SOURCE:** Sanitary Sewer Capital Improvement Fund.

**ATTACHMENTS:** None. Change Order No. 1 is on file in the Office of the City Clerk.

**RECOMMENDATION:** Approve Change Order No. 1.

**PRESENTER:** Lucky Airehrour, Project Engineer.

**9.4 APPROVE LETTER OF AGREEMENT FOR STORMWATER DEVELOPMENT FEE CREDITS WITH WORLD HARVEST CHURCH, ENID, OKLAHOMA, RESULTING FROM IMPROVEMENTS TO OAKWOOD WEST DETENTION FACILITY.**

**BACKGROUND:** The developer for the World Harvest Church, on South Garland Road between W. Owen K. Garriott Road and Rupe Avenue, has removed 7,500 cubic yards of soil from the Oakwood West Detention facility site. City Ordinance allows a developer to receive credits for improvements made to Master Drainage Plan projects to the level of the savings provided to the City by the improvement. The removal of 7,500 cubic yards of soil equates to \$31,875.00 of improvements, which can be used to off-set stormwater development impact fees. An amount of \$8,566.15 of the credits will be used to off-set World Harvest Church's site storm water development fee, and the remaining \$23,308.85 of credits will be available to off-set future stormwater development impact fees in the same basin. The advantage to the public of this agreement is that approximately 30% of the Oakwood West Detention Facility excavation will be provided with no direct cost to the public.

**BUDGETED ITEM:** Not applicable.

**FUNDING SOURCE:** Not applicable.

**ATTACHMENTS:** None. Letter of Agreement is on file in the office of the City Clerk.

**RECOMMENDATION:** Approve Letter of Agreement.

**PRESENTER:** Robert Hitt, P.E., City Engineer.

#### 9.5 APPROVAL OF CLAIMS IN THE AMOUNT OF \$2,406.712.21

**ATTACHMENTS:** List of claims.

10. RECESS TO CONVENE AS THE ENID MUNICIPAL AUTHORITY.

11. TRUSTEES OF THE ENID MUNICIPAL AUTHORITY REGULAR MEETING.

12. ENID MUNICIPAL AUTHORITY REGULAR MEETING.

#### 12.1 CONSIDER APPROVAL OF CONTRACT WITH RALPH CROSS, RINGWOOD, OKLAHOMA, TO ACQUIRE WATER RIGHTS, PROJECT NO. W-1304A.

**BACKGROUND:** Acquiring additional water rights is essential to support the increasing demand as the City of Enid continues to develop. As part of the Water Rights Acquisition Program, an existing water well was tested with excellent results.

The water rights are for a total of 160 acres, which is located on the eastern boundary of the Ringwood Well Field, specifically Northwest

Quarter of Section 12, Range 11, West of the Indian Meridian, Major County, Oklahoma.

This item is presented for approval of a contract to acquire 160 acres of water rights for \$244,000.00.

**BUDGETED ITEM:** Yes.

**FUNDING SOURCE:** Water Capital Improvement Fund.

**ATTACHMENTS:** None. Contract is on file in the Office of the City Clerk.

**RECOMMENDATION:** Approve contract to acquire water rights and authorize payment in amount of \$244,000.00.

**PRESENTER:** Murali Katta, P.E., Project Engineer.

- 12.2 APPROVE AN AGREEMENT ACKNOWLEDGING AND PROVIDING FOR THE PAYMENT OF THE JUDGMENT OF THE WORKERS' COMPENSATION COURT OF THE STATE OF OKLAHOMA ENTERED IN FAVOR OF RICHARD L. WALLACE.

**BACKGROUND:** This is a companion to item 8.3.

**BUDGETED ITEM:** No.

**FUNDING SOURCE:** Tax Rolls.

**ATTACHMENTS:** Acknowledgment of Judgment.

**RECOMMENDATION:** Approve Agreement.

**PRESENTER:** Andrea L. Chism, City Attorney.

- 12.3 APPROVAL OF CLAIMS IN THE AMOUNT OF \$196,483.79.

**ATTACHMENTS:** List of claims.

13. ADJOURN TO CONVENE AS THE ENID ECONOMIC DEVELOPMENT AUTHORITY.
14. TRUSTEES OF THE ENID ECONOMIC DEVELOPMENT AUTHORITY REGULAR MEETING.
15. ENID ECONOMIC DEVELOPMENT AUTHORITY REGULAR MEETING.



**15.1 CONSIDER A RESOLUTION INCREASING THE 2014-2015 FISCAL FINANCIAL PLAN FOR THE ENID ECONOMIC DEVELOPMENT AUTHORITY IN THE AMOUNT OF \$2,035,000.00.**

**BACKGROUND:** The Enid Municipal Authority (EMA) Fiscal Financial Plan was increased by \$2,035,000.00 at the October 21, 2014 EMA meeting to purchase properties on the southeast corner of West Owen K. Garriott Road and Cleveland Street for potential retail development. This item increases the fiscal financial plan in the Enid Economic Development Authority (EEDA) to make the actual purchases. The monies will be transferred from EMA to EEDA to pay for those properties as they become available.

**BUDGETED ITEM:** No. This item increases the EEDA Fiscal Financial Plan.

**FUNDING SOURCE:** Enid Economic Development Authority.

**ATTACHMENTS:** None.

**RECOMMENDATION:** Approve Resolution.

**PRESENTER:** Jerald Gilbert, Chief Financial Officer.

**15.2 EXECUTE CONTRACT TO PURCHASE PROPERTIES AT 2218 E COURT FOR \$60,000.00 AND 2218-2222 C COURT FOR \$75,000.00, FOR A TOTAL OF \$135,000.00, PLUS CLOSING COSTS.**

**BACKGROUND:** This is a companion item to 15.1. Contracts have been signed to purchase two more properties at 2218 E Court Street for \$60,000.00 plus closing costs and 2218-2222 C Court Street for \$75,000.00 plus closing costs, located near the southeast corner of Owen K. Garriott Road and Cleveland Street. The total cost will be \$135,000.00 plus closing costs and the closing dates have not been determined yet. The commission approved pursuing the purchase of these 23 properties at the September 16, 2014 meeting. The Enid Municipal Authority increased the Fiscal Financial Plan on October 21, 2014 to pay for these properties based on the offer prices for all of them.

**BUDGETED ITEM:** Yes.

**FUNDING SOURCE:** Enid Economic Development Authority.

**ATTACHMENTS:** None.

**RECOMMENDATION:** Execute contracts.

**PRESENTER:** Jerald Gilbert, Chief Financial Officer.

15.3 APPROVAL OF CLAIMS IN THE AMOUNT OF \$196,483.79.

16. ADJOURN TO RECONVENE AS THE ENID CITY COMMISSION.

17. PUBLIC DISCUSSION.

18. CONSIDER CONVENING INTO EXECUTIVE SESSION TO DISCUSS THE TERMS OF EMPLOYMENT OF JERALD GILBERT AS CITY MANAGER FOR THE CITY OF ENID, AND TO RECONVENE INTO REGULAR SESSION TO TAKE ANY NECESSARY ACTION.

**BACKGROUND:** The City Attorney recommends the Mayor and Board of Commissioners go into Executive Session pursuant to 25 O.S. §307(B)(1), employment, hiring, appointment, promotion, demotion, disciplining, or resignation of any individual salaried employee. Upon conclusion of the Executive Session, the Commission will reconvene into regular session to take any necessary action.

**PRESENTER:** Andrea L. Chism, City Attorney.

19. REMOVE FROM THE TABLE AND CONSIDER AND EXECUTE AN EMPLOYMENT AGREEMENT WITH JERALD GILBERT FOR THE POSITION OF CITY MANAGER FOR THE CITY OF ENID.

**BACKGROUND:** This item was tabled at the November 4, 2014, Regular Commission Meeting. On October 16, 2014, the Mayor and Board of Commissioners selected Jerald Gilbert to serve as the City's next City Manager. The Mayor and Mr. Gilbert negotiated terms of employment, and the City Commission, in executive session on this date, reviewed and discussed those terms.

**BUDGETED ITEM:** Yes.

**FUNDING SOURCE:** General Fund.

**ATTACHMENT:** None.

**PRESENTER:** Andrea L. Chism, City Attorney.

20. ADJOURN.

MINUTES OF REGULAR MEETING OF  
MAYOR AND BOARD OF COMMISSIONERS OF THE CITY OF ENID, OKLAHOMA,  
TRUSTEES OF THE ENID MUNICIPAL AUTHORITY, A PUBLIC TRUST, AND  
TRUSTEES OF THE ENID ECONOMIC DEVELOPMENT AUTHORITY, A PUBLIC TRUST  
HELD ON THE 4TH DAY OF NOVEMBER 2014

The Mayor and Board of Commissioners of the City of Enid, County of Garfield, State of Oklahoma, the Trustees of the Enid Municipal Authority, a Public Trust, and the Trustees of the Enid Economic Development Authority, a Public Trust, met in regular meeting in the Council Chambers of the Administration Building of the City of Enid, located at 401 West Owen K. Garriott Road in said city, at 6:00 P.M. on the 4th day of November 2014, pursuant to notice given by December 15, 2013 to the Clerk of the City of Enid, and pursuant to notice thereof displayed at the entrance to the Administration Building of said city, in prominent view and which notice was posted prior to 5:00 P.M. on the 3rd day of November 2014.

-MAYOR AND BOARD OF COMMISSIONERS-

Mayor Shewey called the meeting to order with the following members present and absent:

PRESENT: Commissioners Janzen, Brownlee, Ezzell, Timm, Wilson, Vanhooser and Mayor Shewey.

ABSENT: None.

Staff present were City Manager Eric Benson, Assistant City Manager Joan Riley, City Attorney Andrea Chism, City Clerk Linda Parks, Director of Engineering Chris Gdanski, Chief Financial Officer Jerald Gilbert, Director of Public Works Rob Camp, Planning Administrator Chris Bauer, Director of Marketing and Public Relations Steve Kime, Human Services Director Sonya Key, Airport Director Dan Ohnesorge, and Ex-Officio Member Col. Clark Quinn.

\*\*\*\*\*

Pastor Tom Carruthers from Willow View United Methodist Church gave the Invocation, and Mr. Rob Camp led the Flag Salute.

\*\*\*\*\*

Motion was made by Commissioner Timm and seconded by Commissioner Janzen to approve the minutes of the October 21, 2014 special Commission meeting, and the vote was as follows:

AYE: Commissioners Janzen, Brownlee, Ezzell, Timm, Wilson, Vanhooser and Mayor Shewey.

NAY: None.

\*\*\*\*\*

Officer David Handley presented “Lucy,” a two-year old mixed Dachshund, available for adoption at the Enid Animal Shelter.

\*\*\*\*\*

Motion as made by Commissioner Ezzell and seconded by Commissioner Brownlee to approve appointments of the Mayor and Board of Commissioners to the following boards and commissions as listed, and the vote was as follows:

AYE: Commissioners Janzen, Brownlee, Ezzell, Timm, Wilson, Vanhooser and Mayor Shewey.

NAY: None.

Enid Public Transportation Authority	Commissioner Vanhooser
911 Board of Enid, Garfield & Major County	Commissioner Ezzell
Walk of Fame Committee	Commissioners Brownlee and Timm
Enid Regional Development Alliance	Commissioner Brownlee

\*\*\*\*\*

Motion was made by Commissioner Janzen and seconded by Commissioner Ezzell to approve the final plat for New Grange Common, Block 1, and the vote was as follows:

AYE: Commissioners Janzen, Brownlee, Ezzell, Timm, Wilson, Vanhooser and Mayor Shewey.

NAY: None.

\*\*\*\*\*

Discussion was held regarding a final plat for Stonebridge First Addition, Blocks 1 and 2.

Planning Administrator explained that the plat was the first phase of the residential portion of the Stonebridge Planned Unit Development (PUD), and contained 24 lots for single-family residences. He noted that the Metropolitan Area Planning Commission recommended approval of the Final Plat at its October 20, 2014 meeting, contingent upon sidewalks being installed the width of the subdivision along the north side of Chestnut Avenue.

Commissioner Timm asked if the plat could be changed to require sidewalks in front of the residential homes.

Mr. Bauer responded, stating that City Attorney Andrea Chism had advised staff that because this was a PUD, commissioners could negotiate with the developer to make sidewalks a requirement.

Commissioner Vanhooser moved to approve the Final Plat for Stonebridge First Addition, Blocks One and Two, with the requirement that sidewalks be placed on the north side of Chestnut Avenue, as recommended by the Metropolitan Area Planning Commission, and to require interior sidewalks within the residential portion of the PUD.

Motion was seconded by Commissioner Ezzell.

Following further discussion, the vote was taken as follows:

AYE: Commissioners Janzen, Brownlee, Ezzell, Timm, Wilson, Vanhooser and Mayor Shewey.

NAY: None.

\*\*\*\*\*

Motion was made by Commissioner Vanhooser and seconded by Commissioner Janzen to approve the recommendation of the Metropolitan Area Planning Commission, at its meeting of October 20, 2014, to install No Parking and Passenger Loading and Unloading Only signs on the south side of the 500 Block of West Wabash Avenue between South Jefferson Street and South Monroe Street, and the vote was as follows:

AYE: Commissioners Janzen, Brownlee, Ezzell, Timm, Wilson, Vanhooser and Mayor Shewey.

NAY: None.

\*\*\*\*\*

Motion was made by Commissioner Ezzell and seconded by Commissioner Wilson to remove from the table, a Development Reimbursement Agreement for water and sanitary sewer infrastructure with Love's Travel Stops and Country Stores, Inc., and Love's Hospitality, LLC, Oklahoma City, Oklahoma, which was tabled at the October 21, 2014 special Commission meeting, and the vote was as follows:

AYE: Commissioners Janzen, Brownlee, Ezzell, Timm, Wilson, Vanhooser and Mayor Shewey.

NAY: None.

Mr. Brent Kisling, Executive Director of the Enid Regional Development Alliance, explained that Love's was currently under contract to purchase approximately 100 acres of land located near the intersection of U.S. Highway 412 and North 42nd Street to develop a full-service Love's travel stop facility with attendant businesses and hotel. He stated that it was necessary to extend both water and sewer to the site and provide infrastructure for future developments nearby. To expedite the process, Love's agreed to construct the work and advance the funds necessary to pay for the improvements. In return, the Enid Economic Development Authority would reimburse Love's for the City's portion of the project in an amount not to exceed the lesser of sixty-five percent (65%) of the cost, or \$592,410.00, which would be funded by a refund of City sales taxes generated from the travel stop and hotel, with payments to be made quarterly to Love's over a seven (7) year reimbursement period.

Mr. Alex Fuller, representative of the real estate division for Love's Travel Stops and Country Stores, Inc. addressed the Commission. He spoke regarding the project, and answered questions and concerns posed by the Commission.

Following brief discussion, motion was made by Commissioner Ezzell and seconded by Commissioner Brownlee to approve said agreement as presented, and the vote was as follows:

AYE: Commissioners Janzen, Brownlee, Ezzell, Timm, Wilson, Vanhooser and Mayor Shewey.

NAY: None.

\*\*\*\*\*

Motion was made by Commissioner Ezzell and seconded by Commissioner Janzen to award the purchase of Modified Aggregate Quick Set (MAQS) Surfacing System, with surface preparation, to the sole source vendor for said product, Donelson Construction Company, LLC, Clever, Missouri, in the amount of \$732,903.36, and the vote was as follows:

AYE: Commissioners Janzen, Brownlee, Ezzell, Timm, Wilson, Vanhooser and Mayor Shewey.

NAY: None.

\*\*\*\*\*

Motion was made by Commissioner Ezzell and seconded by Commissioner Janzen to award a Professional Services Contract to Poe & Associates, Inc., Oklahoma City, Oklahoma, for Project No. R-1504A, Rehabilitation Design of the Rupe Avenue Bridge Over Boggy Creek (G-19) Structure, at a cost not to exceed \$45,000.00, and authorize the Mayor to execute all contract documents after review by the City Attorney, and the vote was as follows:

AYE: Commissioners Janzen, Brownlee, Ezzell, Timm, Wilson, Vanhooser and Mayor Shewey.

NAY: None.

\*\*\*\*\*

Motion was made by Commissioner Wilson and seconded by Commissioner Ezzell to approve Amendment No. 5 to the Owner-Engineer Agreement dated April 2013 with Cobb Engineering, for engineering services associated with the relocation/replacement of navigational aids required in conjunction with the Runway 17/35 extension project at Enid Woodring Regional Airport, at a cost of \$38,000.00, and the vote was as follows:

AYE: Commissioners Janzen, Brownlee, Ezzell, Timm, Wilson, Vanhooser and Mayor Shewey.

NAY: None.

\*\*\*\*\*

Motion was made by Commissioner Wilson and seconded by Commissioner Ezzell to approve Amendment No. 6 to the Owner-Engineer Agreement dated April 2013 with Cobb Engineering, for construction inspection and administration services in conjunction with the Runway 17/35 extension project at Enid Woodring Regional Airport, at a cost of \$176,000.00, and the vote was as follows:

AYE: Commissioners Janzen, Brownlee, Ezzell, Timm, Wilson, Vanhooser and Mayor Shewey.

NAY: None.

\*\*\*\*\*

Motion was made by Commissioner Janzen and seconded by Commissioner Ezzell to approve staff recommendations on the following Consent Items as listed, and the vote was as follows:

AYE: Commissioners Janzen, Brownlee, Ezzell, Timm, Wilson, Vanhooser and Mayor Shewey.

NAY: None.

- (1) Approval of Change Order No. 1 with Nowak Construction Co., Inc., for Project No. F-1307B, Rolling Oaks Detention Outflow Design Project, which will adjust final quantities delivered at a decrease in the contract of \$10,680.00, for a total revised contract amount of \$235,427.00; and acceptance of work in said project as completed by the contractor;
- (2) Approval of Change Order No. 1 with Sexton Construction, LLC, for Project No. M-1404A, Santa Fe Depot Roof Replacement, which will repair and replace damaged framing decking and joists and provide and install scupper downspout boots at an additional cost of \$2,635.00, for a total revised contract amount of \$72,535.00; and acceptance of work in said project as completed by the contractor;
- (3) Acceptance of pavement improvements in Project No. R-1413A, Chisholm Creek Development, Blocks 10-13;
- (4) Acceptance of permit from the Oklahoma Department of Environmental Quality for Project No. S-1419A, Sanitary Sewer Extension to serve Fire Station No. 4 and future mini storage facility in the 800 Block of South Hoover Street;
- (5) Denial of tort claims filed by Ms. Kerry Murry for alleged property damage in the amount of \$206.38; Ms. Chonage McFalls for alleged property damage in the amount of \$2,677.50; Mr. Billy Sneed for alleged property damage in the amount of \$1,100.00; Mr.



John Stuart for alleged property damage in the amount of \$350.00; and Mr. Larry Zerger for alleged property damage in the amount of \$344.61;

and

(6) Allowance of the following claims for payment as listed:

(List Claims)

\*\*\*\*\*

Mayor Shewey recessed the meeting to convene as the Enid Municipal Authority.

- TRUSTEES OF THE ENID MUNICIPAL AUTHORITY -

PRESENT: Trustees Janzen, Brownlee, Ezzell, Timm, Wilson, Vanhooser, Chairman Shewey, Trust Manager Eric Benson, Trust Attorney Andrea Chism, and Secretary Linda Parks.

ABSENT: None.

\*\*\*\*\*

Motion was made by Trustee Wilson and seconded by Trustee Brownlee to allow the following claims for payment as listed, and the vote was as follows:

AYE: Trustees Janzen, Brownlee, Ezzell, Timm, Wilson, Vanhooser and Chairman Shewey.

NAY: None.

(List Claims)

\*\*\*\*\*

Chairman Shewey adjourned the meeting to convene as the Enid Economic Development Authority.

- TRUSTEES OF THE ENID ECONOMIC DEVELOPMENT AUTHORITY-

PRESENT: Trustees Janzen, Brownlee, Ezzell, Timm, Wilson, Vanhooser, Chairman Shewey, General Manager Eric Benson, Trust Attorney Andrea Chism, and Secretary Linda Parks.

ABSENT: None.

\*\*\*\*\*

Motion was made by Trustee Ezzell and seconded by Trustee Wilson to remove from the table a Development Reimbursement Agreement for water and sanitary sewer infrastructure with Love's Travel Stops and Country Stores, Inc., and Love's Hospitality, LLC, Oklahoma City, Oklahoma, which was tabled at the October 21, 2014 special Enid Municipal Authority meeting, and the vote was as follows:

AYE: Trustees Janzen, Brownlee, Ezzell, Timm, Wilson, Vanhooser and Mayor Shewey.

NAY: None.

Motion was made by Trustee Ezzell and seconded by Trustee Wilson to approve said agreement as presented, and the vote was as follows:

AYE: Trustees Janzen, Brownlee, Ezzell, Timm, Wilson, Vanhooser and Mayor Shewey.

NAY: None.

\*\*\*\*\*

Motion was made by Trustee Janzen and seconded by Trustee Ezzell to allow the following claims for payment as listed, and the vote was as follows:

AYE: Trustees Janzen, Brownlee, Ezzell, Timm, Wilson, Vanhooser and Chairman Shewey.

NAY: None.

(List Claims)

\*\*\*\*\*

Chairman Shewey adjourned the meeting to reconvene as the Enid City Commission.

- MAYOR AND BOARD OF COMMISSIONERS-

Ms. Diane Levesque, 1324 West Oak Avenue, addressed the Commission regarding records received pursuant to a records request she had submitted regarding special events being held on Enid on Halloween, and numerous issues she had regarding the HalloweEnid event held at Meadowlake Park on October 31, 2014.

Following several minutes of circuitous rhetoric, Commissioner Vanhooser called point of order, and asked that Ms. Levesque's remarks be brought to a close.

\*\*\*\*\*

Mr. Bob Berry, 702 North Imo Road, spoke regarding the proposed Comprehensive Plan, and the Stormwater Master Plan, dated August 2008, copies of which were presented to the City Clerk for distribution to commissioners.

\*\*\*\*\*

Motion was made by Commissioner Wilson and seconded by Commissioner Janzen to convene into Executive Session to discuss the terms of employment of Jerald Gilbert for the position of City Manager for the City of Enid, pursuant to 25 O.S. §307(B)(1), employment, hiring, appointment, promotion, demotion, disciplining, or resignation of any individual salaried employee, and the vote was as follows:

AYE: Commissioners Janzen, Brownlee, Ezzell, Timm, Wilson, Vanhooser and Mayor Shewey.

NAY: None.

The meeting convened into Executive Session at 7:19 P.M.

\*\*\*\*\*

In Executive Session the Commission discussed the terms of employment of Jerald Gilbert for the position of City Manager for the City of Enid.

\*\*\*\*\*

Motion was made by Commissioner Ezzell and seconded by Commissioner Janzen to reconvene into regular session, and the vote was as follows:

AYE: Commissioners Janzen, Brownlee, Ezzell, Timm, Wilson, Vanhooser and Mayor Shewey.

NAY: None.

The meeting reconvened into regular session at 8:58 P.M.

\*\*\*\*\*

Motion was made by Commissioner Ezzell and seconded by Commissioner Wilson to table an Employment Agreement with Jerald Gilbert for the position of City Manager for the City of Enid, and the vote was as follows:

AYE: Commissioners Janzen, Brownlee, Ezzell, Timm, Wilson, Vanhooser and Mayor Shewey.

NAY: None.

\*\*\*\*\*

There being no further business to come before the Board at this time, motion was made by Commissioner Ezzell and seconded by Commissioner Timm that the meeting adjourn, and the vote was as follows:

AYE: Commissioners Janzen, Brownlee, Ezzell, Timm, Wilson, Vanhooser and Mayor Shewey.

NAY: None.

The meeting adjourned at 8:59 P.M.

**ORDINANCE NO. 2014-\_\_\_\_**

**AN ORDINANCE AMENDING THE ENID MUNICIPAL CODE, 2014, TITLE 9, ENTITLED "BUILDING REGULATIONS," CHAPTER 4, ENTITLED "ELECTRICAL CODE," SECTION 9-4-3, ENTITLED "AMENDMENTS TO ELECTRICAL CODE" TO AMEND THE QUALIFICATIONS FOR ELECTRICAL INSPECTOR AND CORRECT GRAMMATICAL ERRORS; PROVIDING FOR REPEALER, SAVINGS CLAUSE, SEVERABILITY AND CODIFICATION.**

Section I: That Title 9, Chapter 4, Section 9-4-3 of the Enid Municipal Code, 2014, is hereby to read as follows:

**9-4-3: AMENDMENTS TO ELECTRICAL CODE:**

Article 90 Introduction is hereby amended in the following respects:

90.9 is hereby created to read as follows: All public utilities engaged in the furnishing of electricity, operating under a franchise with the Ccity of Enid, shall be exempt from compliance with this chapter insofar as the same affects property owned or controlled by such utility.

Article 100 Definitions is hereby amended in the following respects:

Insert: Electrical Contractor ~~o~~Or Employing Electrician: Any person engaged in the business of wiring, rewiring, installing, repairing or altering any electrical wiring, or installing or repairing any electrical apparatus, electrical appliances, or electrical equipment.

Insert: Electrical Dealer: Any person engaged in the business of selling or offering for sale electrical materials, devices, apparatus and electrical apparatus and electrical appliances that are not installed by such persons.

Insert: Electrical Equipment: Any electrical wires, appliances, apparatus or electrical construction of any kind whatsoever, installed in or used in or about any building or other structure in the Ccity.

Insert: Electrical Work: Any construction, installation, maintenance or repair of electrical conductors and equipment installed within or on private and public buildings and other premises, including yards, carnival and parking lots, industrial substations, and the conductors that connect the installations to a supply of electricity, and other outside conductors adjacent to the premises; also mobile homes and travel trailers.

Insert: Electrician's Apprentice: A person other than a master or journeyman electrician, who, as his principal occupation, is engaged in learning and assisting in electrical wiring and electrical work, but must be in the company of a licensed master electrician or electrical contractor and must work under the immediate supervision and direction of and in the presence of a master or journeyman electrician.

Insert: Journeyman Electrician: Any person in the employ of an electrical contractor or employing contractor, actually engaged in the work of wiring, rewiring, installing, repairing or altering any electrical wiring, or installing or repairing any electrical apparatus or electrical appliances.

Insert: Master Electrician: Any person who has the qualifications of an electrician and is familiar with the construction of electrical wiring and apparatus, and the hazards involved, and who does the actual work himself, or through journeyman electricians; the term includes contracting or employing electrician.

Article 120 Electrical Inspector is hereby created to read as follows:

- ~~1. Office Created: The office of Electrical Inspector is hereby created in the City of Enid.~~
- ~~2. Appointment: The Electrical Inspector shall be appointed as other appointive officers.~~
31. Qualifications: The minimum qualifications for Electrical Inspector are as set forth in Oklahoma Statutes, which is three (3) years of active experience in the electrical industry. In creating job descriptions and open position, the City Manager may require additional qualifications. ~~shall have at least four (4) years' experience as a journeyman electrician in the practice of his trade, or two (2) years' training in a recognized college of mechanical engineering, and an additional threewo (32) years of practical experience in electrical construction.~~
42. Duties: It shall be the duty of the Electrical Inspector to enforce all laws and ordinances relating to the electrical code, to issue permits, and make such inspections as may be required.
53. Right of Entry for Inspection: Subject to constitutional limitations, the Inspector or his authorized representative shall have the right to enter any premises for the purpose of inspecting the same, at such time as may be reasonably necessary to protect the public health.

Article 130 Permits and Inspections is hereby created to read as follows:

1. Permit Required; Exceptions:
  - a. No electrical work, unless excepted in this section, shall be undertaken prior to issuance of a permit therefore by the Electrical Inspector.
  - b. A permit shall not be required for:
    - 1) Minor repair work, such as repairing flush and snap switches, replacing fuses, changing lamp sockets and receptacles, taping bare joints, and replacing drop cords,

- 2) Maintenance and repairs on the premises of a person regularly employing journeymen electricians for that purpose.

2. Permit Application, Issuance ~~a~~And Fee: An electrical permit shall be issued after application has been made therefore, and upon the forms prescribed by the city, showing that the ordinances of the ~~C~~eity will be complied with, and upon payment of the fee provided for in ~~t~~Title 2, ~~e~~Chapter 6, ~~a~~Article F of the Enid ~~M~~municipal ~~C~~eode.
3. Inspection ~~a~~And Concealment ~~o~~Of Certain Wires: All wires which are to be hidden from view shall be inspected before concealment, and the person doing the electrical work shall notify the ~~E~~lectrical ~~I~~nspector to make the required inspection before such wires are concealed, and shall not conceal the same until permission has been obtained in writing from the ~~E~~lectrical ~~I~~nspector.
4. Inspection Fee: A fee as provided in ~~t~~Title 2, ~~e~~Chapter 6, ~~a~~Article F of the Enid ~~M~~municipal ~~C~~eode shall be paid to the ~~d~~irector of ~~f~~inance for each electrical inspection to be made.
5. Certificate ~~o~~Of Inspection ~~o~~Or Service Permit: Upon the completion of wiring in any building, structure or place, the licensee installing the same shall notify the ~~e~~lectrical ~~i~~nspector, who shall cause the installation to be inspected, and, if found to be in compliance with this chapter, shall issue a certificate of inspection, or service permit, authorizing connection to the electrical circuit, and the energizing of the installation. No such connection or energizing shall be made until such a certificate or service permit is issued.
6. Triple Fees Authorized: All fees are tripled if work is started prior to the issuance of any permit. Existing equipment change outs shall be permitted to start prior to inspection and issuance of permit. The assessment and/or payment of triple fees shall in no way prevent further penalty, such as suspension or revocation of a license and/or permit for excessive repetition of violations.

Article 140 Electricians is hereby created to read as follows:

1. State License Required: Any electrical contractor, journeyman electrician or apprentice electrician who performs work in the ~~e~~City is required to have ~~an~~ ~~state-Oklahoma~~ license.
2. Registration Required; Marking ~~o~~Of Vehicles:
  - a. No person, as principal, agent, manager, or employee, shall conduct, manage or carry on the trade, calling or business of an electrical contractor, or do any electrical work of any kind or description in the ~~C~~eity, for which an electrical permit is required, without registering with the ~~C~~eity ~~C~~lerk and securing a registration from the ~~C~~eity. The ~~C~~eity ~~C~~lerk shall issue such registration upon presentation of a valid ~~e~~lectrical ~~e~~Contractor's ~~H~~License issued by the ~~s~~State of

Oklahoma and upon payment of the required fee and posting of bond, where required.

- b. All vehicles used in electrical work shall have signs stating the name of the contractor and the City registration number in letters at least two inches (2") high affixed to both sides of the vehicle.

3. Issuance of Registration:

- a. The City Clerk shall issue an electrical contractor's registration upon presentation of the state license<sup>2</sup>, bond where required, and payment of the annual fees as established in fTitle 2, eChapter 6, aArticle F of the Enid Mmunicipal Code.
- b. All registrations shall expire July 31 of the following year after their issuance. Penalty fees shall be charged for late registration as established in fTitle 2, eChapter 6, aArticle F of the Enid Mmunicipal Code.
- c. All services performed by utility companies operating under franchise agreements, and the employees of such utility companies, are hereby exempt from subsection 3a of this section for work done under the supervision and direction of said utility companies.

4. Revocation of Registration:

- a. Subsequent to a hearing, conducted as hereinafter provided in this subsection, the Construction Board of Appeals may recommend the suspension or revocation of an electrical contractor registration issued pursuant to this eCode to the Mayor and Board of Commissioners if it has reason to believe or finds that the holder has:
  - 1) Made a material misstatement in the application for any registration or renewal thereof;
  - 2) Loaned or illegally used his registration;
  - 3) Violated any provisions of this Code; or,
  - 4) Committed any act specified in this Code as grounds for suspension and/or revocation of any registration.
- b. Complaints against any person registered under this chapter may be filed with the Board by the Office of the Electrical Inspector. Such complaint shall be investigated by or before the Board. All complaints must be in writing, signed and duly verified by the Office of Electrical Inspector. This procedure shall not



be exclusive and shall not preclude the filing of a complaint in the Municipal Court.

c. The person against whom a complaint is signed shall be entitled to a public hearing before the Board. Within ten (10) days after the filing of a written complaint, the Board shall serve written notice of the complaint upon the registered person. The notice shall be served either personally or by certified mail, return receipt requested. If the notice is served personally, it must be served at least ten (10) days prior to any scheduled hearing. If the notice is served by mail, it must be postmarked at least ten (10) days prior to any scheduled hearing. The notice shall include:

- 1) A statement of the time, place and nature of the hearing;
- 2) A statement of the legal authority and jurisdiction under which the hearing is to be held;
- 3) A reference to the particular sections of the Code and rules involved;
- 4) A copy of the complaint;
- 5) A statement that the accused has a right to a public hearing in his defense at which time he may respond to the allegations in the complaint by his testimony, the testimony of witnesses, or other admissible evidence;
- 6) A statement that the individual has a right to be represented by legal counsel and a right to confront his accusers; and,
- 7) A statement that, based upon the evidence presented at the hearing, the Board shall decide to either dismiss the complaint or recommend suspension or revocation of the registration.

d. The Board, in its hearing, shall follow the rules of evidence of the state. All writings or documents admitted into evidence shall become part of the record of the proceedings. A party or members of the Board may conduct direct and cross examinations required for a full and true disclosure of the facts. After all evidence has been submitted, the Board shall vote to either dismiss the complaint or recommend to the Mayor and Board of Commissioners suspension or revocation of the registration. A recommended suspension shall include a recommendation for the period of time during which the registration is to be suspended; provided, however, that a registration cannot be suspended for a period of time exceeding six (6) months. (Ord. 2013-14, 2-21-2013, eff. 4-1-2013)

Section II: Repealer. All ordinances or parts thereof, which are inconsistent with this ordinance, are hereby repealed.

Section III: Savings Clause. Nothing in this ordinance hereby adopted shall be construed to affect any suit or proceedings now pending in any court, or any rights acquired or liability incurred, nor any cause or causes of action accrued or existing, under any act or ordinance repealed hereby. Nor shall any right or remedy of any character be lost, impaired or affected by this ordinance.

Section IV: Severability. If any one or more of the sections, sentences, clauses or parts of this ordinance, chapter or section shall, for any reason, be held invalid, the invalidity of such section, clause or part shall not affect or prejudice in any way the applicability and validity of any other provision of this ordinance. It is hereby declared to be the intention of the City Commission of the City of Enid that this section of the Enid Municipal Code would have been adopted had such unconstitutional, illegal or invalid sentence, clause, section or part not been included.

Section V: Codification. This ordinance shall be codified as Title 9, Chapter 4, Section 9-4-3 of the Enid Municipal Code, 2014.

PASSED AND APPROVED by the Mayor and Board of Commissioners of the City of Enid, Oklahoma, on this 18th day of November, 2014.

CITY OF ENID, OKLAHOMA

---

William E. Shewey, Mayor

(SEAL)

ATTEST:

---

Linda S. Parks, City Clerk

Approved as to Form and Legality:

---

Andrea L. Chism, City Attorney

## RESOLUTION

**A RESOLUTION AUTHORIZING THE CITY ATTORNEY TO LEVY A JUDGMENT OF THE WORKERS' COMPENSATION COURT OF THE STATE OF OKLAHOMA ENTERED IN FAVOR OF RICHARD L. WALLACE, AND AGAINST THE CITY OF ENID, IN THE AMOUNT OF THIRTY SIX THOUSAND DOLLARS (\$36,000.00); PROVIDING THAT THIS JUDGMENT WILL BE LEVIED PURSUANT TO 62 O.S. §§ 365.1-365.6 AND TITLE 2, CHAPTER 3, SECTION 2-3-2D OF THE ENID MUNICIPAL CODE, 2014; APPROVING AN AGREEMENT ACKNOWLEDGING SUCH JUDGMENT; PROVIDING FOR THE PAYMENT OF SUCH JUDGMENT IN EXCHANGE FOR THE CITY'S PROMISE TO REPAY SUCH JUDGMENT FROM COLLECTED TAX LEVIES; AND DECLARING AN EMERGENCY.**

### EMERGENCY RESOLUTION

**WHEREAS**, RICHARD L. WALLACE suffered a work-related injury to his right shoulder on February 27, 2013, during the course of his employment; and,

**WHEREAS**, This matter was adjudicated before the Workers' Compensation Court of the State of Oklahoma on October 22, 2014, with the Court entering an Order awarding RICHARD L. WALLACE Thirty Six Thousand Dollars (\$36,000.00; and,

**WHEREAS**, the Mayor and Board of Commissioners deem it in the best interest of the City of Enid to take the actions as provided for in this Resolution.

**NOW, THEREFORE**, be it resolved by the Mayor and Board of Commissioners of the City of Enid, that:

1. This judgment shall be levied as provided by 62 O.S. §§ 365.1 - 365.6 and Title 2, Chapter 3, Section 2-3-2D of the Enid Municipal Code, 2014; and be paid as follows:
  - A. Payment on June 15, 2016, of one-third (1/3) of the principal amount together with statutory interest, if any, accrued to date;
  - B. Payment on June 15, 2017, of one-third (1/3) of the principal amount with statutory interest, if any, accrued since first payment;
  - C. Payment on June 15, 2018, of the balance of the principal and statutory interest due, if any.
2. An agreement acknowledging such judgment pursuant to an Acknowledgment of Judgment attached hereto and providing for the payment of such judgment in exchange for the City's promise to repay such judgment from collected tax levies

is hereby approved.

PASSED AND APPROVED by the Mayor and Board of Commissioners on the 18th day of November, 2014.

THE CITY OF ENID, OKLAHOMA

---

William E. Shewey, Mayor

ATTEST

(SEAL)

---

Linda S. Parks, City Clerk

Approved as to Form and Legality

---

Andrea L. Chism, City Attorney

**ORDINANCE NO. 2014-**

**AN ORDINANCE AMENDING THE ENID MUNICIPAL CODE, 2014, TITLE 10, ENTITLED “PLANNING AND DEVELOPMENT,” CHAPTER 4 ENTITLED “CAPITAL IMPROVEMENT AND RECOVERY,” SECTION 10-4-3 TO IDENTIFY LOCATION OF SIDEWALK REGULATIONS AND CORRECT GRAMMATICAL ERRORS; CREATING TITLE 10, ENTITLED “CAPITAL IMPROVEMENT AND RECOVERY,” CHAPTER 6, ENTITLED “SIDEWALKS,” SECTIONS 10-6-1 AND 10-6-2 TO RELOCATE SIDEWALK REGULATIONS AND EXPAND THE REQUIREMENT TO PROVIDE SIDEWALKS TO ALL DEVELOPMENTS AND REDEVELOPMENTS; AMENDING TITLE 12, ENTITLED “SUBDIVISIONS,” CHAPTER 6, ENTITLED “SUBDIVISION DESIGN STANDARDS,” SECTION 12-6-2, ENTITLED “STREET,” TO RELOCATE SIDEWALK REGULATIONS AND CORRECT GRAMMATICAL ERRORS; AMENDING TITLE 12, ENTITLED “SUBDIVISIONS,” CHAPTER 8, ENTITLED “CONSTRUCTION PLANS AND SPECIFICATION,” SECTION 12-8-7, ENTITLED “SIDEWALK CONSTRUCTION PLANS,” TO UPDATE SIDEWALK SPECIFICATIONS IN ACCORDANCE WITH FEDERAL LAWS AND REGULATIONS; PROVIDING FOR REPEALER, SAVINGS CLAUSE, SEVERABILITY, AND CODIFICATION.**

**ORDINANCE**

BE IT ORDAINED BY THE MAYOR AND BOARD OF COMMISSIONERS OF THE CITY OF ENID, OKLAHOMA:

Section I: That Title 10, Chapter 4, Section 10-4-3, of the Enid Municipal Code, 2014, is hereby amended to read as follows:

**10-4-3: CAPITAL IMPROVEMENT REQUIREMENTS:**

The purpose of this **s**Section is to identify capital improvements required to support the efficient and effective growth and development of the **e**City of Enid, limit financial impact on the **e**City of Enid and establish development responsibility to provide capital improvements.

A. Water System:

1. New development sites shall extend the public water system across the length of the subdivision or developed site.
2. Water system improvements shall comply with **s**Section 8-2-14 of this **e**Code.

B. Sanitary Sewer System:

1. New development sites shall extend the public sanitary sewer system to the site.
2. Sanitary sewers shall be constructed to the size requirement specified in the ~~e~~City of Enid ~~s~~Sanitary ~~s~~ewer ~~m~~Master ~~p~~lan, but not less than the capacity required for development site.

C. Stormwater System:

1. New development shall provide improvement of the public stormwater system to transport stormwater through the development site in accordance with ~~t~~Title 12, "Subdivisions", of this ~~e~~Code.
2. New development shall mitigate the impact from the development site by improving the downstream drainageways to comply with ~~t~~Title 12, "Subdivisions", of this ~~e~~Code, or include an improvement plan to mitigate the impact by on site detention or other acceptable means. The mitigation shall cover the impact from the development site to the main drainage channel as defined in the ~~e~~City of Enid ~~s~~Stormwater ~~m~~Master ~~p~~lan.

D. Transportation System:

1. New development shall provide that public roads within the development must be in compliance with ~~t~~Title 12, "Subdivisions", of this ~~e~~Code.
2. Subdivision development on arterial streets shall provide acceleration and decelerations lanes, per ~~t~~Title 12 of this ~~e~~Code.
3. Development, under ~~s~~Section 11-11-2, "~~s~~Site ~~p~~lan ~~r~~Review," of this ~~e~~Code, shall provide public infrastructure improvements as required by the site plan process to provide for adequate and safe vehicular access to adjacent streets.

E. Sidewalks:

1. New development and redevelopment shall provide sidewalks in accordance with ~~subs~~Section ~~12-6-2~~~~Y~~~~10-6-1~~ and ~~s~~Section 12-8-7 of this ~~e~~Code.

F. Fire Protection System:

1. New development and redevelopment shall provide fire hydrants in accordance with the ~~i~~nternational ~~f~~ire ~~e~~Code as adopted by the ~~e~~City. (Ord. 2010-14, 12-14-2010)

Section II: That Title 10, Chapter 6, is hereby created to read as follows:

**Chapter 6**  
**SIDEWALKS**

**10-6-1: SIDEWALKS REQUIRED:**

- A. All developments and redevelopments must include sidewalks that parallel all abutting streets.
- B. Multifamily residential, commercial, educational, industrial and public gathering developments must incorporate sidewalks within its development.

**10-6-2: SIDEWALK SPECIFICATIONS:**

- A. Sidewalks shall comply with the most current accessibility guidelines associated with the Americans with Disabilities Act.
- B. Sidewalks shall be constructed using the minimum specifications provided in Section 12-8-7 of this Code.
- C. Should a conflict arise between guidelines associated with the Americans with Disabilities Act and the specifications provided in Section 12-8-7, the more restrictive shall apply.

Section III: That Title 12, Chapter 6, Section 12-6-2, of the Enid Municipal Code, 2014, is hereby amended to read as follows:

**12-6-2: STREETS:**

- A. Conformity: The arrangement, character, extent, width, grade and location of all streets shall conform to the ~~City's most current eC~~omprehensive ~~p~~Plan and ~~specifically the Enid area long range t~~ransportation ~~p~~Plan, ~~1994~~, and shall be considered in their relation to existing and planned streets, to topographical conditions, to public convenience and safety, and in their appropriate relation to the proposed uses of the land to be served by such streets, where not shown on the transportation plan map, the arrangement and other design standards of streets shall conform to the provisions found herein.
- B. Relation ~~F~~to Adjoining Street System: The arrangement of streets in a new subdivision shall make provision for the continuation of the existing streets in adjoining areas.
- C. Projection ~~O~~f Streets: Where adjoining areas are not subdivided, the arrangement of streets in a new subdivision shall make provisions for the proper projection of streets.
- D. Streets Carried ~~F~~to Property Lines: When a new subdivision adjoins an undeveloped parcel of land susceptible of being subdivided, then the new streets shall be carried to the boundaries of the tract proposed to be subdivided.
- E. Street Jogs Prohibited: Street jogs at intersections with centerline offsets of less than one hundred feet (100') shall be avoided.

F. Dead End Street ~~Or~~ Cul-De-Sac: Dead end streets or cul-de-sacs designed to be so permanently, shall not be longer than six hundred feet (600') in length, and shall be provided at the closed end with a turnaround having an outside roadway diameter of at least eighty feet (80'), and a street property line diameter of at least one hundred feet (100'). If a dead end street is of a temporary nature, a similar turnaround shall be provided and provisions made for future extension of the street into adjoining properties. If the cul-de-sac is less than one hundred fifty feet (150') in length, the turnaround may be omitted. Each turnaround may have a center island of not less than twenty feet (20') in diameter. Each island shall be approved with the final plat. Approved islands will be curbed, and if unpaved, any plantings shall not interfere with sight clearance.

G. Arterial Streets: Where a subdivision abuts or contains within its boundaries an arterial street which has not been improved to the design standards specified in the ~~Enid-area long-range transportation plan, 1994~~ City's most current Transportation Plan, an accel-decel turning lane shall be provided where any street within the subdivision intersects the arterial street to afford separation of through and local traffic. This requirement shall not apply to private residential drives.

H. Local ~~Or~~ Minor Streets: Local streets shall be so laid out that their use by through traffic will be discouraged.

I. Street Right ~~Of~~ Way Widths:

1. Street widths shall not be less than as follows:

<u>Street Type</u>	<u>Width (Feet)</u>
Arterial	120
Collector	80
Residential collector	60
Local, apartments	60
Local, all others	50
Cul-de-sac	50
Frontage or marginal access	40

2. In front of areas designated and zoned for commercial use, or where a petition for a change in zoning is contemplated to permit such use, the street width shall be increased by such amount on each side as may be deemed necessary by the



planning commission to assure the free flow of through traffic without interference by parked vehicles and to provide safe parking space for such commercial district.

- J. Intersections: The intersections of more than two (2) streets at one point shall be avoided, except where it is impracticable to secure a proper street system otherwise. Streets shall intersect one another at an angle as near to a right angle as possible, and no intersections of streets at angles less than sixty degrees (60°) shall be approved. Street intersections shall be rounded with a radius of twenty five feet (25') measured at the face of curbs when the said intersection occurs at right angles. If an intersection occurs at an angle other than a right angle, it shall be rounded with a curve of a radius acceptable to the planning commission. In commercial or industrial zoning districts, the planning commission may permit comparable cutoffs or chords.
- K. Street Deflections: When connecting street lines which connect between intersections deflect from each other, they shall be connected by a curve with a radius adequate to ensure a sight distance of not less than two hundred feet (200').
- L. Reverse Curves: A tangent shall be introduced between reverse curves on arterial and collector streets sufficient to provide for the smooth flow of traffic.
- M. Subdivision ~~I~~nto Tracts Larger ~~T~~han Ordinary Building Lots: Where a tract is subdivided into larger parcels than are ordinarily permitted, such parcels shall be arranged so as to allow the opening of future streets and logical further resubdivision.
- N. Reserve Strips: Reserve strips controlling access to streets shall be prohibited, except under conditions approved by the planning commission and when such strips are owned by the ~~e~~City.
- O. Ingress ~~A~~nd Egress: Ingress and egress to residential property shall not be provided on arterial streets.
- P. Street Grades: No street grade shall be less than three-tenths of one percent (0.3%), and shall not exceed eight percent (8%) or eleven percent (11%) on local streets, with due allowance for reasonable vertical curves.
- Q. Railroad ~~O~~r Highway Abutting Subdivision: Where a subdivision borders on or contains a railroad right of way or limited access highway right of way, the planning commission may require a street approximately parallel to, and on each side of, such right of way, at a distance suitable for the appropriate use of the intervening land, or for park purposes in residential districts, or for commercial or industrial purposes in appropriate districts. Such distance shall also be determined with due regard for the requirements of approach grades and future grade separations.
- R. Half Streets Prohibited: Half streets shall be prohibited, except where essential to the reasonable development of the subdivision in conformity with the other requirements of

these regulations and where the planning commission finds it will be practicable to require the dedication of the other half when the adjoining property is subdivided. Wherever a half street is adjacent to a tract to be subdivided, the other half of the street shall be platted within such tract.

- S. Street Names ~~A~~and Numbers: Names of new streets shall not duplicate existing or platted street names unless a new street is a continuation of, or in alignment with, the existing or platted street. All street names shall be subject to approval by the planning commission. So far as practicable, street names shall be grouped in categories and names within a category shall be used in only one area of the city, streets which continue in a straight line shall continue with the same name; streets which curve to the extent that they intersect with other parallel streets shall have a separate name for that portion of the street. House numbers shall be assigned by the ~~e~~Code ~~a~~Administration ~~d~~Department of the ~~e~~City.
- T. Access ~~F~~to Streets Across Ditches: The subdivider shall provide access to all proposed streets, across all ditches, in a standard method approved by the director of engineering services.
- U. Vacation ~~O~~of Streets: The Metropolitan Area pPlanning ~~e~~Commission shall not recommend the vacation of any street or part of a street dedicated for public use, if such vacation interferes with the uniformity of the existing street pattern or any future street plan prepared for the area.
- V. Private Streets: Public improvements shall not be approved for any private street or drive, unless expressly recommended for approved by the Metropolitan Area pPlanning ~~e~~Commission.
- W. Hardship ~~F~~to Owners ~~O~~of Adjoining Property Avoided: The street arrangement shall not be such as to cause hardship to owners of adjoining property in platting their own land and providing convenient access to it.
- X. Street Interval: In general, provisions should be made for through streets at intervals not exceeding one-half ( $1/2$ ) mile along arterial streets.
- Y. Sidewalks: Sidewalks ~~must comply with the Americans with disabilities act (the ADA) and section 12-8-7 of this title. All commercial developments which abut Owen K. Garriott Road, Van Buren Street, an arterial highway, an auxiliary service highway, an arterial street or a collector street must include sidewalks that parallel those streets. Industrial developments where sidewalks are planned for the street that runs parallel to the development must incorporate sidewalks into its development. Redevelopment of residential subdivisions that were originally developed with sidewalks must include sidewalks.~~shall be required pursuant to Section 10-6-1 of this Code and shall comply with Section 12-8-7 of this Code.-(Ord. 2011-16, 10-18-2011)

Section IV: That Title 12, Chapter 8, Section 12-8-7, of the Enid Municipal Code, 2014, is hereby amended to read as follows:

## 12-8-7: SIDEWALK CONSTRUCTION PLANS:

- A. The maximum slope of a sidewalk is one to twenty (1:20) or five percent (5%). Sidewalks with slopes greater than one to twenty (1:20) or five percent (5%) are considered ramps and must comply with the ~~ADA, the ADA accessibility guidelines for buildings and facilities (ADAAG)~~, most current accessibility guidelines associated with the Americans with Disabilities Act or regulations promulgated by the ~~d~~Department of ~~j~~Justice for ramps.
1. Exception: Sidewalks that run parallel to a street may have a grade matching the road grade.
- B. The surface of the sidewalk must be paved and slip resistant with no changes in level greater than one-fourth inch ( $\frac{1}{4}$ ").
- C. The plans must include curb ramps with detectable warnings, any necessary signals or signage and for residential subdivisions it must include a plan for each individual lot.
- D. The minimum clear width of sidewalks that run parallel to local streets is forty eight inches (48") and along other roads the minimum clear width is sixty inches (60").
- E. Every sidewalk must provide a clear passing width of at least sixty inches by sixty inches (60" x 60") located at intervals not to exceed two hundred feet (200').
- F. Driveway crossings must not create a cross slope for the sidewalk of more than ~~two-one~~ and one-half percent (~~2~~1 $\frac{1}{2}$ %).
- G. The minimum headroom is eighty inches (80").
- H. Gratings may not have openings greater than one-half inch ( $\frac{1}{2}$ " ) and the long dimension of the openings must run perpendicular to the direction of travel.
- I. Sidewalks that include directional signs must include Braille with the baseline of the tactile characters between forty eight inches (48") and sixty inches (60").
- J. Curb ramps should be designed consistent with the following:
1. Provide a level maneuvering area at the top of the curb ramp;
  2. Clearly identify the boundary between the bottom of the curb ramp and the street with a detectable warning that extends the full width of the ramp and runs for twenty four inches (24") from the bottom of the ramp;
  3. Place the curb ramp within the marked crosswalk area;

4. Design the ramp so that it does not require turning or maneuvering on the ramp surface;
5. Design the ramp with a maximum grade of ~~8.37.1~~ percent;
6. Design the ramp and gutter with a cross slope of ~~two one and one-half~~ percent (~~2~~ $1\frac{1}{2}$ %) maximum;
7. Provide adequate drainage to prevent accumulation of water or debris at the bottom of the ramp;
8. Transitions from ramps to gutter and streets are flush and free of level changes; and
9. Align the curb ramps with the crosswalk so there is a straight path of travel from the top of the ramp to the center of the roadway to the curb ramp on the other side.

K. Detectable warnings for curb ramps should consist of truncated domes with:

1. A bottom diameter of twenty three millimeters (23 mm) (0.9 inch);
2. A top diameter of ten millimeters (10 mm) (0.4 inch);
3. A height of five millimeters (5 mm) (0.2 inch);
4. A center to center spacing of sixty millimeters (60 mm) (2.35 inches); and
5. A visual contrast from the adjacent pavement.

L. When sidewalks are being constructed or modified along streets that have already been constructed, these standards may need to be modified to adjust to the particular layout of the land, property, street and utilities. Care should be taken to ensure accessibility is enhanced and not diminished by construction but strict compliance may not be feasible. In these circumstances parallel curb ramps, blended transitions, or other designs may be utilized. (Ord. 2009-09, 4-7-2009)

Section V: Repealer. All ordinances or parts thereof, which are inconsistent with this ordinance, are hereby repealed.

Section VI: Savings Clause. Nothing in this ordinance hereby adopted shall be construed to affect any suit or proceedings now pending in any court, or any rights acquired or liability incurred, nor any cause or causes of action accrued or existing, under any act or ordinance repealed hereby. Nor shall any right or remedy of any character be lost, impaired or affected by this ordinance.

Section VII: Severability. If any one or more of the sections, sentences, clauses or parts of this ordinance, chapter or section shall, for any reason, be held invalid, the invalidity of such section, clause or part shall not affect or prejudice in any way the applicability and validity of any other provision of this ordinance. It is hereby declared to be the intention of the City Commission of the City of Enid that this section of the Enid Municipal Code would have been adopted had such unconstitutional, illegal or invalid sentence, clause, section or part not been included.

Section VIII: Codification. This ordinance shall be codified as Title 10, Chapter 4, Section 10-4-3, Title 10, Chapter 6, Sections 10-6-1 and 10-6-2, Title 12, Chapter 6, Section 12-6-2 and Title 12, Chapter 8, Section 12-8-7 of the Enid Municipal Code, 2014.

PASSED AND APPROVED by the Mayor and Board of Commissioners of the City of Enid, Oklahoma, on this 18th day of November, 2014.

CITY OF ENID, OKLAHOMA

---

William E. Shewey, Mayor

(SEAL)

ATTEST:

---

City Clerk, Linda Parks

Approved as to Form and Legality:

---

Andrea L. Chism, City Attorney

AFTER RECORDING RETURN TO:  
OG&E ELECTRIC SERVICES  
ATTN: FIELD SERVICE AGENT  
1401 N 54TH ST  
ENID, OK 73701

## UTILITY EASEMENT

Work Order # 7934658

KNOW ALL MEN BY THESE PRESENTS:

That the City of Enid, an Oklahoma Municipal Corporation, "Grantor," in consideration of the sum of one dollars (\$1.00) and other good and valuable consideration, the receipt and sufficiency of which is hereby acknowledged, does hereby grant unto Oklahoma Gas and Electric Company, an Oklahoma Corporation, its successors and assigns, "Grantee," a Utility Easement, under, over and across the following described real property and premises, situated in Garfield County, State of Oklahoma, to-wit:

### SEE ATTACHED EXHIBIT "A"

with right of ingress and egress to and from same, for the purpose of installing, erecting, operating, maintaining and reconstructing, underground and/or above ground, a system of conduits, wires, cables, vaults, junction boxes, switches, fuses, transformers, service connection boxes and other fixtures for the transmission and distribution of electrical current and communication messages. Such easement and right of way shall be used solely for the benefit of Woodring Regional Airport and shall not be used to provide electrical current, communication messages, or any other service to other any other person and/or entity without prior written consent of the City of Enid.

Grantor hereby consents to permit Grantee to trim trees and foliage within the easement and the immediately adjacent property. Any such trimming shall be done with prior notice to Grantor and in a manner that ensures the health and aesthetics of the trees and foliage involved.

Grantor covenants and agrees that no building or other structure shall be erected over, nor shall any excavation or other removal of soil, so as to change the grade of the terrain, be accomplished within the above described easement area without the Grantee's prior written consent, which shall not be unreasonably withheld. Grantor acknowledges the Underground Facilities Damage Prevent Act, 63 O.S. § 142.1, et seq.

All rights granted herein shall continue so long as the Utility Easement is used by Grantee for the transmission and distribution of electric current. Should Grantee remove its property from the premises, the rights granted in this easement shall immediately terminate.

Signed and delivered this 18th day of November, 2014.

---

William E. Shewey, Mayor

(SEAL)

ATTEST:

\_\_\_\_\_  
Linda Parks, City Clerk

**MUNICIPAL CORPORATION ACKNOWLEDGEMENT**

State of Oklahoma    )  
  ) ss.  
County of Garfield    )

Before me, the undersigned, a Notary Public in and for said County and State, on this \_\_\_\_ day of November, 2014, personally appeared William E. Shewey, to me known to be the identical person who subscribed the name of the maker thereof to the foregoing instrument as its Mayor, and acknowledged to me that he/she executed the same as the free and voluntary act and deed of such corporation, for the uses and purposes therein set forth.

\_\_\_\_\_  
Notary Public

My Commission Number: \_\_\_\_\_

My Commission Expires: \_\_\_\_\_



## EXHIBIT "A"

November 11, 2014

### O.G. & E. 7 FOOT WIDE EASEMENT DESCRIPTION WOODRING AIRPORT

(WO#7934658)

PART OF SECTION TWENTY-FOUR (24), TOWNSHIP TWENTY TWO (22) NORTH, RANGE SIX (6) WEST OF THE INDIAN MERIDIAN, GARFIELD COUNTY, OKLAHOMA, AS SHOWN ON ATTACHED EXHIBIT "B", BEING MORE PARTICULARLY DESCRIBED AS FOLLOWS:

COMMENCING AT THE SOUTHEAST CORNER OF THE SOUTHWEST QUARTER SEC.24;

THENCE NORTH  $00^{\circ} 21' 27''$  WEST\* ALONG THE EAST LINE OF SAID SOUTHWEST QUARTER SEC. 24, FOR A DISTANCE OF 1319.69 FEET;

THENCE SOUTH  $89^{\circ} 38' 33''$  WEST, PERPENDICULAR TO THE EAST LINE OF SAID SOUTHWEST QUARTER SEC. 24, FOR A DISTANCE OF 8.93 FEET TO THE POINT OF BEGINNING OF EASEMENT "A";

THENCE NORTH  $18^{\circ} 11' 36''$  WEST ALONG THE CENTERLINE OF OG&E 7 FOOT WIDE EASEMENT, FOR A DISTANCE OF 372.98 FEET;

THENCE NORTH  $00^{\circ} 02' 54''$  WEST ALONG THE CENTERLINE OF OG&E 7 FOOT WIDE EASEMENT, FOR A DISTANCE OF 315.16 FEET TO REFERENCE POINT "B";

THENCE NORTH  $00^{\circ} 05' 25''$  WEST ALONG THE CENTERLINE OF OG&E 7 FOOT WIDE EASEMENT, FOR A DISTANCE OF 1317.86 FEET;

THENCE NORTH  $03^{\circ} 28' 29''$  EAST ALONG THE CENTERLINE OF OG&E 7 FOOT WIDE EASEMENT, FOR A DISTANCE OF 646.77 FEET TO THE POINT OF TERMINATION OF EASEMENT "A";

AND

BEGINNING AT ABOVE DESCRIBED REFERENCE POINT "B";

THENCE SOUTH  $89^{\circ} 45' 41''$  EAST ALONG THE CENTERLINE OF OG&E 7 FOOT WIDE EASEMENT, FOR A DISTANCE OF 1172.79 FEET TO THE POINT OF TERMINATION OF EASEMENT "B".

ABOVE DESCRIBED EASEMENTS CONTAINS 0.614 ACRES, MORE OR LESS.

\* ALL BEARINGS SHOWN HEREON ARE RELATIVE TO NAD 83 GRID BEARINGS.



# EXHIBIT "B"

EASEMENT LOCATION SURVEY  
 PART OF SECTION 24,  
 TOWNSHIP 22 NORTH, RANGE 6 WEST, I. M.  
 GARFIELD COUNTY, OKLAHOMA

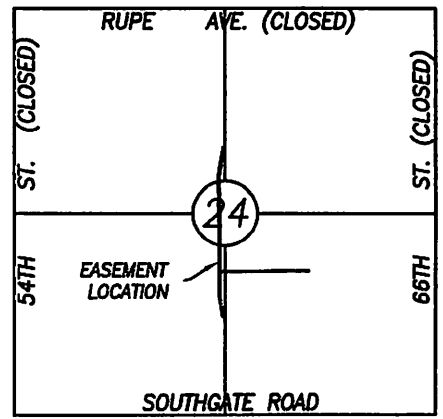
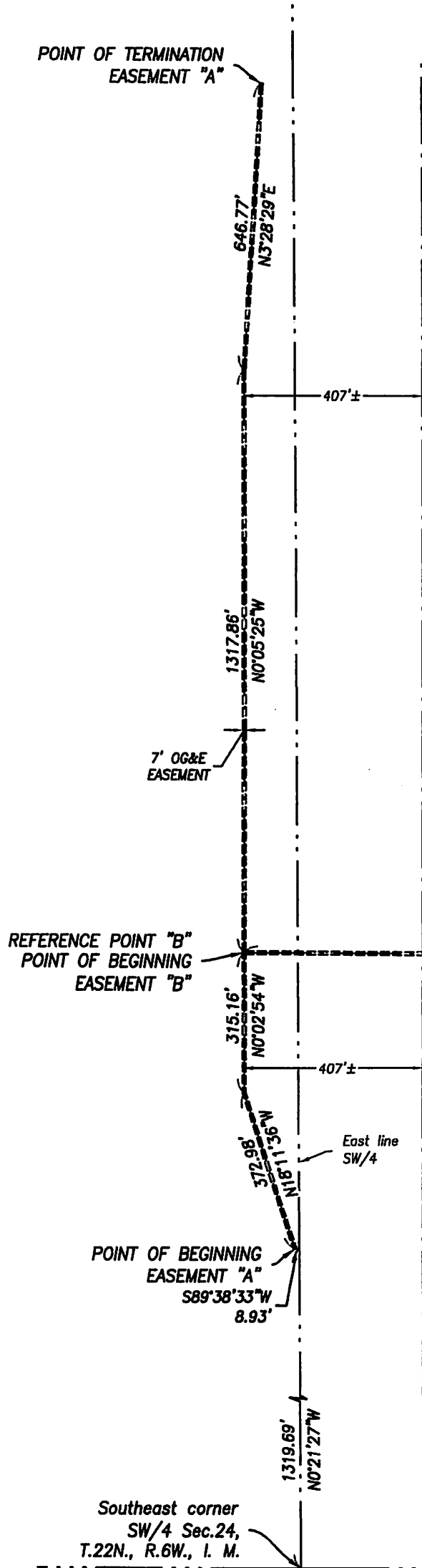

**POSITIONAL ACCURACY**  
 Unless otherwise noted hereon all monuments established by this survey have a minimum positional accuracy of 0.10 feet.

**NOTICE!**

No record title search was performed to determine if subject tract is affected by other easements and or rights-of-way not shown hereon.

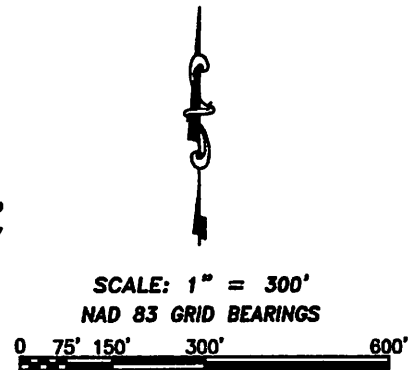

**SURVEY SUMMARY:**

Established the south line of Section 24 using Certified Corner Records and the north-south quarter section line from previous survey information. Met James Pine on the site and located the route of proposed easement as it was field staked.

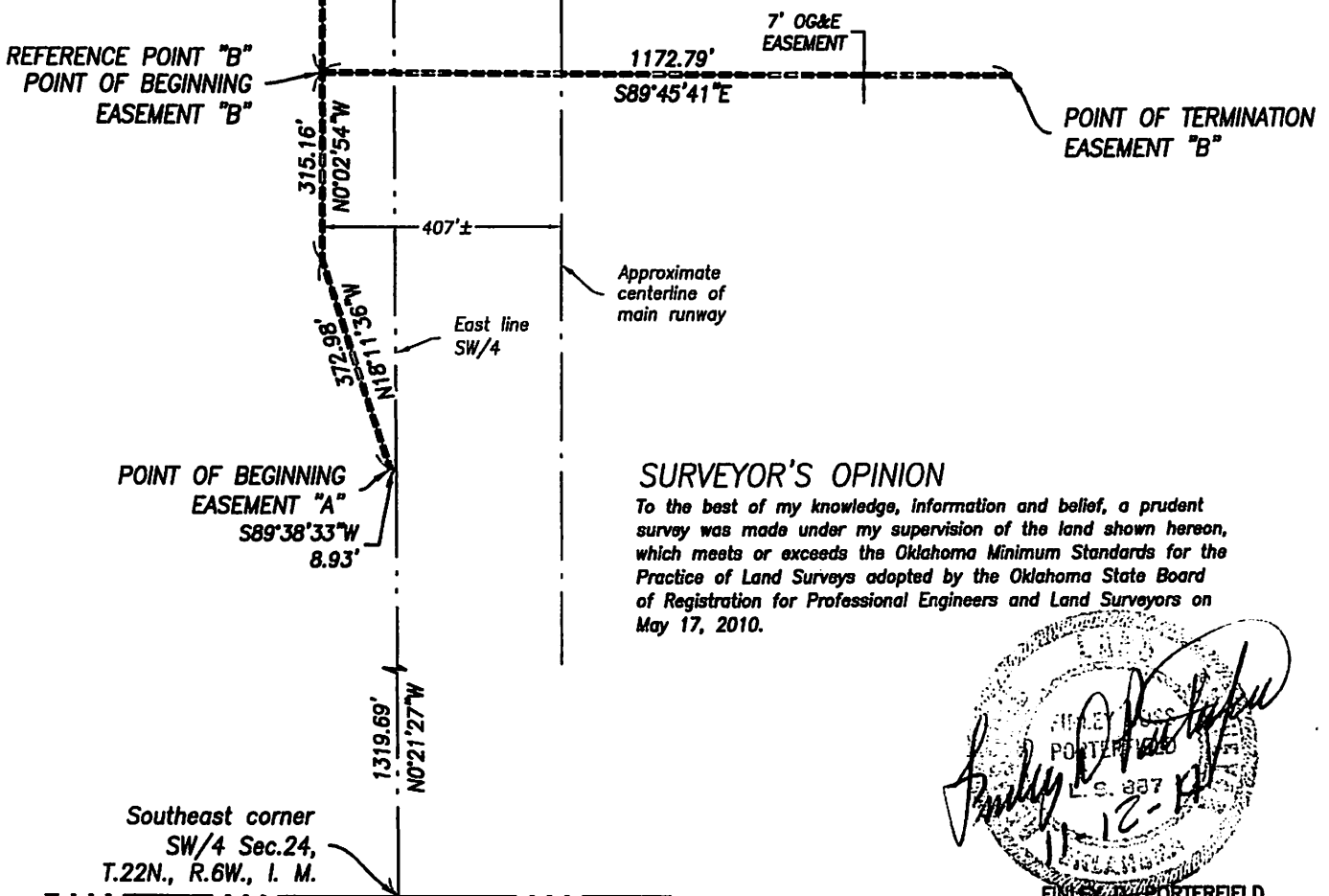

**SURVEYOR'S OPINION**

To the best of my knowledge, information and belief, a prudent survey was made under my supervision of the land shown hereon, which meets or exceeds the Oklahoma Minimum Standards for the Practice of Land Surveys adopted by the Oklahoma State Board of Registration for Professional Engineers and Land Surveyors on May 17, 2010.

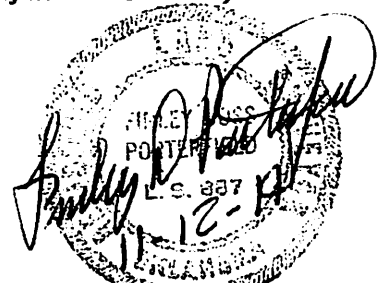

FILED BY PORTERFIELD  
 R.P.L.S. NO. 887

**EXHIBIT "B"**

FILE NO. 20140211\BASEMAP

DATE OF SURVEY: 11-7-2014  
 DATE SIGNED: 11-11-2014  
 CLIENT: OG&E WO#7934858



**PORTERFIELD SURVEYING, INC.**

PROFESSIONAL LAND SURVEYING SERVICES  
 1610 N. IMO ROAD, Enid, Oklahoma 73703  
 Ph. 580-233-0572, Fax 580-233-0583 E-mail 'tp@pp-us.com'  
 C.A. No. 828, Expiration Date: June 30, 2015

Revision date      Scope

- 1.
- 2.
- 3.

## RESOLUTION

A RESOLUTION CANVASSING RETURNS OF THE SPECIAL ELECTION HELD IN THE CITY OF ENID, OKLAHOMA, ON NOVEMBER 4, 2014, ON ORDINANCE NO. 2014-29, GRANTING TO ONE GAS, INC. A FRANCHISE FOR A PERIOD OF TWENTY-FIVE YEARS.

**WHEREAS**, the County Election Board of Garfield County, Oklahoma, has certified the results of the Special Election held in the City of Enid, Oklahoma, on November 4, 2014, on the proposition granting to One Gas, Inc. a franchise for a period of twenty-five (25) years; and,

**WHEREAS**, the Mayor and Board of Commissioners of the City of Enid, Oklahoma, have canvassed the returns and find that at said Special Election so held, the proposition was approved by a majority vote of the qualified electors voting thereon.

**NOW THEREFORE, BE IT RESOLVED**, by the City of Enid, by and through its Mayor and Board of Commissioners as follows:

Section I: A canvass of the election returns of the Special Election held in the City of Enid, on November 4, 2014, on the proposition of granting to One Gas, Inc. a franchise for the term of twenty-five (25) years, shows that a total of six thousand six hundred and eight (6,608) votes were cast in favor of granting the franchise, and two thousand six hundred and eighty-eight (2,688) votes were cast against the proposition, resulting in a majority of votes cast at said election in favor of granting the franchise.

Section II: As a result of the passage of the proposition by the qualified electors of the City of Enid, City of Enid Ordinance No. 2014-29 shall become operative upon acceptance by One Gas, Inc.

PASSED AND APPROVED this 18th day November, 2014.

THE CITY OF ENID, OKLAHOMA

---

William E. Shewey, Mayor

(SEAL)

ATTEST:

---

Linda S. Parks, City Clerk

Approved as to form and legality:

---

Andrea L. Chism, City Attorney

FROM: James Neal, Deputy Director of Public Works, City of Enid  
PAGE 1 OF 1  
DATE: 18 November 2014

CANVASS OF BIDS  
for  
**CONCRETE REPAIRS**  
**R-1505A**

<u>FIRM NAME AND ADDRESS</u>	<u>PRODUCT/SERVICE BID</u>	<u>PRICE</u>
Derwin's Construction, LLC 422 E. Indiana, Enid OK 73701 Days to construct - N/A	Total Bid	\$ 145,500.00

Bid meets or exceeds all major specifications:  X  YES   NO  
Bid meets or exceeds all minor specifications:   YES  X  NO

DEVIATIONS: Affidavits were omitted from the bid package, but received by the City Clerk November 6, 2014.

RECOMMENDATION: Award a contract to Derwin's Construction, LLC in the amount of \$145,500.00.

**IN THE DISTRICT COURT OF GARFIELD COUNTY  
STATE OF OKLAHOMA**

RICHARD L. WALLACE,	)	
	)	
Plaintiff,	)	
	)	
vs.	)	Case No.
	)	
THE CITY OF ENID,	)	
	)	
Defendant.	)	

**ASSIGNMENT OF JUDGMENT**

IN CONSIDERATION of the sum of THIRTY SIX THOUSAND DOLLARS (\$36,000.00), receipt of which is hereby acknowledged, I, RICHARD L. WALLACE, in whose favor a foreign judgment from the Workers' Compensation Court of the State of Oklahoma, was or will be entered and docketed in the District Court of Garfield County, State of Oklahoma, on or before the 28th day of November, 2014, against the City of Enid, Oklahoma, a Municipal Corporation, for the sum of THIRTY SIX THOUSAND DOLLARS (\$36,000.00) (which shall bear interest at the judgment rate on the unpaid balance), do hereby sell, assign and/or transfer to Enid Municipal Authority, a Public Trust, all right, title, interest and ownership in that judgment and acknowledge that I will not collect, receive, release, nor discharge said judgment or any part thereof, but will allow all lawful proceedings thereon by The Enid Municipal Authority, a Public Trust, saving me harmless from any costs and charges in the premises except the payment of court costs of said action, which shall be paid by The City of Enid.

DATED this \_\_\_\_\_ day of \_\_\_\_\_, 2014.

\_\_\_\_\_  
RICHARD L. WALLACE

**RESOLUTION**

**A RESOLUTION INCREASING THE 2014-2015 FISCAL FINANCIAL PLAN FOR THE ENID ECONOMIC DEVELOPMENT AUTHORITY IN THE AMOUNT OF \$2,035,000.00.**

**WHEREAS**, the amounts for the 2014-2015 Enid Economic Development Authority (EEDA) fiscal financial plan must be increased by \$2,035,000.00 to pursue the purchase of properties in the southeast corner of Cleveland and Garriott that was approved by the Commission on September 16, 2014; and

**WHEREAS**, funds will be provided from the Enid Municipal Authority which the Trustees increased by \$2,035,000.00 at the October 21, 2014 council meeting; and

**WHEREAS**, monies are expected to be recouped when the properties are sold to a retail developer;

**AND NOW, THEREFORE, BE IT RESOLVED BY THE CHAIRMAN AND BOARD OF TRUSTEES OF THE ENID ECONOMIC DEVELOPMENT AUTHORITY, THAT THE ENID ECONOMIC DEVELOPMENT AUTHORITY 2014-2015 FISCAL FINANCIAL PLAN BE INCREASED IN THE FOLLOWING AMOUNTS:**

<b>FUND 32 ENID ECONOMIC DEVELOPMENT AUTHORITY</b>	
Revenue	\$2,035,000.00
EEDA	\$2,035,000.00

Adopted this 18<sup>th</sup> day of November 2014.

\_\_\_\_\_  
Chairman

(Seal)

ATTEST:

\_\_\_\_\_  
City Clerk

## PURCHASE ORDER CLAIMS LIST

11/18/2014

**FUND 10 DEPT 000 - N.A.**

01-01472	STAPLES ADVANTAGE	PO0125013	SURGE PROTECTORS/ST	\$91.45
01-02082	AT&T MOBILITY	PO0124870	MONTHLY SERVICE 10/14	\$5,282.43
01-03030	OKLAHOMA UNIFORM BUILDING CODE COM	PO0125009	OUBCC FEES 10/14	\$468.00
01-03718	BUSINESS WORLD, INC.	PO0124962	COPIER MAINTENANCE 11/14	\$69.40
01-04613	WICKENS, JAMES	PO0124880	REFUND/ADOPTION FEE	\$85.00
01-04616	TAYLOR, SHARON S.	PO0124956	REFUND/PARKING TICKET	\$170.00
01-15125	OK GAS & ELECTRIC	PO0124937	MONTHLY SERVICE 10/14	\$1,105.51
01-15125	OK GAS & ELECTRIC	PO0124938	MONTHLY SERVICE 10/14	\$33,526.70
01-15125	OK GAS & ELECTRIC	PO0124939	MONTHLY SERVICE 10/14	\$6,464.45
01-15125	OK GAS & ELECTRIC	PO0124940	MONTHLY SERVICE 10/14	\$843.20
01-15125	OK GAS & ELECTRIC	PO0124948	MONTHLY SERVICE 10/14	\$129,444.84
01-15127	OK NATURAL GAS	PO0125000	MONTHLY SERVICE 10/14	\$287.96
01-16010	PIONEER TELEPHONE CO., INC.	PO0124872	MONTHLY SERVICE 11/14	\$685.55
01-19047	AT & T	PO0124930	MONTHLY SERVICE 11/14	\$1,559.28
01-67400	WESTEL	PO0124919	MONTHLY SERVICE 10/14	\$458.66
01-70950	COPIERS PLUS, INC.	PO0124925	MONTHLY MAINTENANCE 10/14	\$879.37
			<b>N.A. TOTAL</b>	<b>\$181,421.80</b>

**FUND 10 DEPT 100 - ADM. SERVICES**

01-01163	ADVANCED WATER SOLUTIONS	PO0124914	WATER COOLER RENTAL 11/14	\$36.85
01-01783	JP MORGAN CHASE	PO0125061	CHASE PAYMENT	\$1,963.08
01-04116	DOWNTOWN THREADS	PO0124913	LOGO SHIRTS (4)	\$147.32
01-04319	NAPA AUTO PARTS-WAREHOUSE	PO0124879	WAREHOUSE PARTS 9/14	\$265.02
01-04501	THE PACE GROUP	PO0122441	PROFESSIONAL SERVICES	\$37,795.12
01-04569	DESTINY SOFTWARE, INC.	PO0125064	ANNUAL SOFTWARE SUPPORT	\$5,725.00
01-04610	EDGAR CRUZ	PO0124866	ENTERTAINMENT/RETIREMENT	\$1,000.00
01-04611	DOUG SWANSON	PO0124867	ENTERTAINMENT/RETIREMENT	\$200.00
01-08022	HUGHES LUMBER CO., LLC	PO0124959	DRILL BIT	\$25.00
01-16145	PETTY CASH	PO0125055	REIMB/TRAVEL/J RILEY	\$234.94
01-36830	MAIN STREET ENID, INC.	PO0125063	SPONSORSHIP/ELUTP	\$1,500.00
01-60600	ENID FLORAL & GIFTS	PO0124989	FLORAL ARRANGEMENTS (3)	\$204.74
			<b>ADM. SERVICES TOTAL</b>	<b>\$49,097.07</b>

**FUND 10 DEPT 110 - HUMAN RESOURCES**

01-01338	J & P SUPPLY, INC.	PO0124994	TOWELS/METERED DISPENSER	\$115.75
01-01338	J & P SUPPLY, INC.	PO0125045	CUTLERY KITS/CLEANER/BRUSH	\$76.25
01-01783	JP MORGAN CHASE	PO0125061	CHASE PAYMENT	\$885.80
01-02082	AT&T MOBILITY	PO0125035	MONTHLY SERVICE 10/14	\$15.60
01-02838	NATIONAL PUBLIC EMPLOYER LABOR REL	PO0125038	ANNUAL MEMBERSHIP FEE/S KEY	\$175.00
01-03463	OKPELRA	PO0125044	2014 FALL SEMINAR/S KEY	\$75.00
01-04129	OK DEPT. OF CORRECTIONS	PO0125042	INMATE COSTS/DOC VAN USAGE	\$841.38
01-04319	NAPA AUTO PARTS-WAREHOUSE	PO0124879	WAREHOUSE PARTS 9/14	\$189.24
01-04621	STEPHENS, TIMOTHY	PO0125050	TUITION SCHOLARSHIP	\$1,000.00
01-05017	ENID TYPEWRITER CO., INC.	PO0125041	TONER/PRINTS	\$377.20
01-16145	PETTY CASH	PO0125055	REIMB/TRAVEL/S KEY	\$113.74
01-16145	PETTY CASH	PO0125074	RETIREMENT GIFTCARDS (2)	\$606.00
01-18022	RUSCO PLASTICS	PO0125039	RETIREMENT PLAQUES (2)	\$65.90
			<b>HUMAN RESOURCES TOTAL</b>	<b>\$4,536.86</b>

**FUND 10 DEPT 120 - LEGAL SVCS.**

01-01284	MOORAD, AMAL E. MD.	PO0124977	WC/MEDICAL	\$1,211.94
01-01305	WORKERS' COMP COURT	PO0124863	WC/FILING FEE	\$140.00
01-01783	JP MORGAN CHASE	PO0125061	CHASE PAYMENT	\$249.58
01-03701	TYLER TECHNOLOGIES, INC.	PO0125076	SUBSCRIPTION FEES 8/14	\$1,867.32
01-03701	TYLER TECHNOLOGIES, INC.	PO0125076	SUBSCRIPTION FEES 9/14	\$1,964.18
01-03921	EXPRESS SCRIPTS, INC.	PO0124976	WC/MEDICAL	\$1,391.60
01-04020	PAIN MANAGEMENT OF TULSA	PO0124982	WC/MEDICAL	\$88.74
01-04425	STREAMCARE LLC	PO0124985	WC/MEDICAL	\$2,884.20
01-04556	PHARMTOX SOLUTIONS, LLC.	PO0124986	WC/MEDICAL	\$1,776.47
01-04563	XPRESS WELLNESS, LLC	PO0124980	WC/MEDICAL	\$58.91
01-04608	OK WORKERS COMP COMM	PO0124859	OWN RISK APP PERMIT	\$1,000.00
01-04618	EDWARD ARENS C/O BOETTCHER	PO0125015	WC/MILEAGE REIMB	\$101.68
01-19194	OK TAX COMMISSION	PO0124862	WC SETTLEMENT TAX	\$990.00

01-33380	OPFER, DAVID	PO0124865	WC/MEDICAL	\$317.36
01-33380	OPFER, DAVID	PO0124922	WC/MEDICAL	\$317.36
<b>LEGAL SVCS. TOTAL</b>				<b>\$14,359.34</b>

**FUND 10 DEPT 140 - SAFETY**

01-01163	ADVANCED WATER SOLUTIONS	PO0124941	WATER COOLER RENTAL 11/14	\$19.65
01-01783	JP MORGAN CHASE	PO0125061	CHASE PAYMENT	\$173.28
01-02466	FireCO OF OKLAHOMA, INC.	PO0124878	BATTERY/EYE WASH STATION	\$90.00
<b>SAFETY TOTAL</b>				<b>\$282.93</b>

**FUND 10 DEPT 150 - PR/MARKETING**

01-01082	CLASSIC PRINTING	PO0125069	COE NEWSLETTER 12/14	\$1,680.00
01-02421	SUDDENLINK	PO0125046	MONTHLY SERVICE 11/14	\$169.64
01-04116	DOWNTOWN THREADS	PO0124983	LOGO HATS (44)/FIREBALL RUN	\$157.52
01-04319	NAPA AUTO PARTS-WAREHOUSE	PO0124879	WAREHOUSE PARTS 9/14	\$16.82
01-49880	DELL MARKETING, LP	PO0124321	COMPUTER/MONITORS (2)	\$2,062.11
<b>PR/MARKETING TOTAL</b>				<b>\$4,086.09</b>

**FUND 10 DEPT 200 - GENERAL GOVERNMENT**

01-01338	J & P SUPPLY, INC.	PO0125045	CUPS	\$32.66
01-01783	JP MORGAN CHASE	PO0125061	CHASE PAYMENT	\$388.36
01-02656	ROGGOW CONSULTING	PO0122888	CONSULTING SERVICES 10/14	\$4,000.00
01-04569	DESTINY SOFTWARE, INC.	PO0125064	ANNUAL SOFTWARE SUPPORT	\$5,725.00
01-05145	ENID METRO AR HM SER COMM	PO0122957	2014-2015 PROGRAM FUNDING 10/14	\$3,975.00
01-10040	JUMBO FOODS, INC.	PO0124912	MEAL/COUNCIL MEETING	\$349.75
01-39700	GARFIELD CO. LEGAL NEWS	PO0124997	PUBLICATIONS	\$106.10
01-41900	GARFIELD CO. ELECTION BOARD	PO0125057	BALLOTS/ONG ELECTION	\$4,428.50
01-42400	AT & T	PO0124936	MONTHLY SERVICE 10/14	\$356.01
01-58150	MCAFFEE & TAFT	PO0124944	PROFESSIONAL SERVICE	\$653.22
<b>GENERAL GOVERNMENT TOTAL</b>				<b>\$20,014.60</b>

**FUND 10 DEPT 210 - ACCOUNTING**

01-01163	ADVANCED WATER SOLUTIONS	PO0124967	WATER COOLER RENTAL 11/14	\$23.55
01-01783	JP MORGAN CHASE	PO0125061	CHASE PAYMENT	\$136.00
01-16145	PETTY CASH	PO0125055	REIMB/TRAVEL/E CRAWFORD	\$297.47
01-49370	GFOA OF OKLAHOMA	PO0125001	ANNUAL MEMBERSHIP DUES (2)	\$305.00
<b>ACCOUNTING TOTAL</b>				<b>\$762.02</b>

**FUND 10 DEPT 220 - RECORDS & RECEIPTS**

01-01472	STAPLES ADVANTAGE	PO0124918	STAMP INK	\$5.19
01-16004	PDQ PRINTING	PO0124881	ALARM LABELS (800)	\$590.00
<b>RECORDS &amp; RECEIPTS TOTAL</b>				<b>\$595.19</b>

**FUND 10 DEPT 250 - INFORMATION TECHNOLOGY**

01-01783	JP MORGAN CHASE	PO0125061	CHASE PAYMENT	\$611.90
<b>INFORMATION TECHNOLOGY TOTAL</b>				<b>\$611.90</b>

**FUND 10 DEPT 300 - COMMUNITY DEVELOPMENT**

01-01783	JP MORGAN CHASE	PO0125061	CHASE PAYMENT	\$378.00
<b>COMMUNITY DEVELOPMENT TOTAL</b>				<b>\$378.00</b>

**FUND 10 DEPT 350 - CODE ENFORCEMENT**

01-02639	RON'S MOWING SERVICE	PO0125005	MOW/608 W NAGEL	\$75.00
01-02639	RON'S MOWING SERVICE	PO0125005	MOW/1403 W ELM	\$75.00
01-02639	RON'S MOWING SERVICE	PO0125005	MOW/802 S INDEPENDENCE	\$75.00
01-03711	PLUMB RIGHT	PO0125052	SEWER/1127 S WASHINGTON	\$2,300.00



01-03924	GIRLS GETTER DONE	PO0124999	MOW/1602 W ELM	\$85.00
01-04319	NAPA AUTO PARTS-WAREHOUSE	PO0124879	WAREHOUSE PARTS 9/14	\$7.60
01-04552	ADVANCE SERVICES	PO0124966	MOW/122 MARGARET CIRCLE	\$500.00
01-16145	PETTY CASH	PO0125074	FILING FEES	\$481.00
			<b>CODE ENFORCEMENT TOTAL</b>	<b>\$3,598.60</b>

**FUND 10 DEPT 400 - ENGINEERING**

01-01472	STAPLES ADVANTAGE	PO0124918	HEATER/DATE STAMP	\$56.98
01-01783	JP MORGAN CHASE	PO0125061	CHASE PAYMENT	\$285.01
01-02116	MESHEK & ASSOCIATES, PLC	PO0116411	G-1402A PROFESSIONAL SERVICES	\$7,830.00
01-03327	ARC	PO0124142	G-1402A PROFESSIONAL SERVICES	\$7,390.08
01-03927	GEOSHACK, INC.	PO0124998	HUBSTAKES (300)	\$80.43
01-04319	NAPA AUTO PARTS-WAREHOUSE	PO0124879	WAREHOUSE PARTS 9/14	\$98.74
01-16145	PETTY CASH	PO0125078	REIMB/TRAVEL/J ORTIZ-LOPEZ	\$113.25
01-72030	EXPRESS PERSONNEL SERVICES, INC.	PO0125037	TEMP EMPLOYEE	\$500.80
			<b>ENGINEERING TOTAL</b>	<b>\$16,355.29</b>

**FUND 10 DEPT 700 - PUBLIC WORKS MGMT**

01-01783	JP MORGAN CHASE	PO0125061	CHASE PAYMENT	\$3,972.38
01-02082	AT&T MOBILITY	PO0125043	MONTHLY SERVICE 10/14	\$296.10
01-02515	ENID EYE OPTICAL, INC.	PO0124987	GLASSES/N RAMIREZ	\$127.00
01-04319	NAPA AUTO PARTS-WAREHOUSE	PO0124879	WAREHOUSE PARTS 9/14	\$3,934.79
01-08022	HUGHES LUMBER CO., LLC	PO0124959	LUMBER/HAMMER	\$178.69
01-64080	AIRGAS	PO0124886	CYLINDER RENTAL	\$85.34
01-64080	AIRGAS	PO0124886	GLOVES/ELECTRODES	\$84.60
01-70950	COPIERS PLUS, INC.	PO0124925	MONTHLY MAINTENANCE 10/14	\$7.50
			<b>PUBLIC WORKS MGMT TOTAL</b>	<b>\$8,686.40</b>

**FUND 10 DEPT 710 - FLEET MAINTENANCE**

01-01783	JP MORGAN CHASE	PO0125061	CHASE PAYMENT	\$268.96
01-04319	NAPA AUTO PARTS-WAREHOUSE	PO0124879	WAREHOUSE PARTS 9/14	\$3,868.57
			<b>FLEET MAINTENANCE TOTAL</b>	<b>\$4,137.53</b>

**FUND 10 DEPT 730 - PARKS & RECREATION**

01-00878	BROWN'S SHOE FIT COMPANY	PO0124895	BOOTS/T BOLING	\$94.50
01-01783	JP MORGAN CHASE	PO0125061	CHASE PAYMENT	\$3,115.55
01-01943	JOHNSTON SEED COMPANY, INC.	PO0122403	GRASS SEED	\$3,375.00
01-02082	AT&T MOBILITY	PO0125043	MONTHLY SERVICE 10/14	\$23.11
01-03107	CHEM-CAN SERVICES, INC.	PO0124928	PORTABLE TOILET RENTAL (2 MO)	\$737.00
01-04319	NAPA AUTO PARTS-WAREHOUSE	PO0124879	WAREHOUSE PARTS 9/14	\$10,521.32
01-08022	HUGHES LUMBER CO., LLC	PO0124916	LUMBER	\$7.87
01-13145	MID-AMERICA WHOLESale	PO0124924	POOL CONCESSIONS	\$1,490.16
01-35300	UNIFIRST, INC.	PO0124929	LAUNDRY BAGS/MATS/WIPERS	\$193.29
01-51190	JACK'S OUTDOOR POWER EQUIPMENT	PO0124896	OIL/EDGER BLADE	\$37.95
01-51190	JACK'S OUTDOOR POWER EQUIPMENT	PO0124926	AIR FILTER/EDGER BLADES	\$32.76
01-56300	TRUCK PRO, INC.	PO0124927	OIL CAP	\$23.99
01-70950	COPIERS PLUS, INC.	PO0124925	MONTHLY MAINTENANCE 10/14	\$52.00
01-80246	ATWOODS	PO0124894	CABLE TIES	\$74.95
01-80246	ATWOODS	PO0124957	BOOTS/P RUNCO III	\$119.99
01-80246	ATWOODS	PO0124957	BOOTS/R DONNELL	\$99.99
01-80473	ACE HARDWARE-SOUTHERN HARDLINES	PO0124897	CULTIVATOR/CLEANSER	\$33.96
			<b>PARKS &amp; RECREATION TOTAL</b>	<b>\$20,033.39</b>

**FUND 10 DEPT 740 - STRMWTR & ROADWAY MAINT.**

01-01616	BRANSON CONCRETE PUMPING	PO0124882	PROFESSIONAL SERVICE	\$950.00
01-01783	JP MORGAN CHASE	PO0125061	CHASE PAYMENT	\$342.25
01-04319	NAPA AUTO PARTS-WAREHOUSE	PO0124879	WAREHOUSE PARTS 9/14	\$17,869.50
			<b>STRMWTR &amp; ROADWAY MAINT. TOTAL</b>	<b>\$19,161.75</b>

**FUND 10 DEPT 750 - TECHNICAL SERVICES**

01-01783	JP MORGAN CHASE	PO0125061	CHASE PAYMENT	\$2,002.39
01-04131	UNITED RENTALS (NORTH AMERICA), IN	PO0125021	SAW RENTAL	\$256.28
01-04319	NAPA AUTO PARTS-WAREHOUSE	PO0124879	WAREHOUSE PARTS 9/14	\$2,719.15
01-07030	GADES SALES CO., INC.	PO0125059	CAMERA REPLACEMENTS (2)	\$1,990.00
01-16008	PINKLEY SALES CO.	PO0125058	REPAIR/VIDEO PROCESSOR	\$1,978.00
			<b>TECHNICAL SERVICES TOTAL</b>	<b>\$8,945.82</b>

**FUND 10 DEPT 900 - LIBRARY**

01-00551	PROQUEST INFORMATION AND LEARNING	PO0125010	ONLINE SERVICE 10/14	\$878.00
01-01249	THE FRAMER	PO0124933	FRAMEWORK REPAIR/AWARDS	\$1,040.30
01-01338	J & P SUPPLY, INC.	PO0124934	LINERS	\$44.13
01-01338	J & P SUPPLY, INC.	PO0125003	RAGS	\$18.30
01-01783	JP MORGAN CHASE	PO0125061	CHASE PAYMENT	\$6,859.35
01-02313	TEC-AN, INC.	PO0125014	ASBESTOS TEST/INSPECTION	\$490.00
01-03590	SKINNER AUDIO SERVICES	PO0125072	SOUND SYSTEM	\$1,639.90
01-03825	BIBLIONIX, LLC	PO0124961	SUBSCRIPTION (6 MO)	\$2,619.30
01-15019	OK HISTORICAL SOCIETY	PO0125008	MICROFILM SUBSCRIPTION (4 MO)	\$205.00
01-15039	OK LIBRARY ASSOCIATION	PO0124873	ANNUAL DUES (4)	\$236.00
01-15039	OK LIBRARY ASSOCIATION	PO0124932	ANNUAL DUES/M HOLMES	\$81.00
01-16145	PETTY CASH	PO0125055	REIMB/TRAVEL/L BALLARD	\$228.93
01-16145	PETTY CASH	PO0125078	REIMB/TRAVEL/G CUMPSTON	\$143.36
01-49880	DELL MARKETING, LP	PO0124327	OPTIPLEX 7010 COMPUTERS (5)	\$3,560.30
01-55120	QUILL CORPORATION, INC.	PO0124955	COFFEE/TEA/CARD STOCK	\$39.47
01-70950	COPIERS PLUS, INC.	PO0124931	COPIER USAGE 10/14	\$352.57
			<b>LIBRARY TOTAL</b>	<b>\$18,435.91</b>

**FUND 10 DEPT 950 - SALES TAX TRANS.**

01-03060	CENTRAL NATIONAL BANK	PO0125017	EMA SALES TAX TRANSFER 11/14	\$744,055.62
01-19099	SECURITY NATIONAL BANK	PO0125020	SCHOOL SALES TAX TRANSFER 11/14	\$113,086.49
01-77520	BANK OF OKLAHOMA, NA	PO0125019	SCHOOL BOND TAX TRANSFER 11/14	\$85,077.98
			<b>SALES TAX TRANS. TOTAL</b>	<b>\$942,220.09</b>

**FUND 10 DEPT 955 - CAPITAL ASSETS & PROJECTS**

01-01783	JP MORGAN CHASE	PO0125061	CHASE PAYMENT	\$284.07
01-04555	JVC AMERICAS CORP	PO0123919	IT-1403A JVC QUOTE/CH00873-03	\$652.00
			<b>CAPITAL ASSETS &amp; PROJECTS TOTAL</b>	<b>\$936.07</b>

**FUND 12 DEPT 125 - SPECIAL PROJECT**

01-04009	COVERTRACK GROUP, INC.	PO0124964	ANNUAL MAPPING SUBSCRIPTION	\$600.00
01-49880	DELL MARKETING, LP	PO0124617	LAPTOPS (2)	\$2,123.48
			<b>SPECIAL PROJECT TOTAL</b>	<b>\$2,723.48</b>

**FUND 14 DEPT 145 - HEALTH FUND**

01-64810	WORKSITE BENEFIT PLANS, INC.	PO0125034	125 PLAN FEES 10/14	\$432.60
01-70870	FOCUS INSTITUTE, INC.	PO0125056	EAP SERVICES 10/14	\$1,233.33
01-78180	BLUE CROSS BLUE SHIELD OK	PO0125054	DENTAL FEES 10/14	\$1,817.92
01-78180	BLUE CROSS BLUE SHIELD OK	PO0125054	DENTAL CLAIMS 10/14	\$16,651.66
01-78180	BLUE CROSS BLUE SHIELD OK	PO0125054	HEALTH ADMIN FEES 10/14	\$41,251.91
01-78180	BLUE CROSS BLUE SHIELD OK	PO0125054	HEALTH CLAIMS 10/14	\$417,164.11
			<b>HEALTH FUND TOTAL</b>	<b>\$478,551.53</b>

**FUND 20 DEPT 205 - AIRPORT**

01-01338	J & P SUPPLY, INC.	PO0125002	DRUG SCREENING TESTS	\$25.07
01-01783	JP MORGAN CHASE	PO0125061	CHASE PAYMENT	\$833.63
01-02243	BB MACHINE & SUPPLY, INC.	PO0124970	LOCK VALVES (2)	\$38.76
01-02269	CEC CORPORATION	PO0122399	A-1301C RUNWAY EXTENSION	\$11,500.00
01-02269	CEC CORPORATION	PO0123275	A-1301A EXTEND/LIGHT/RUNWAY	\$18,700.00
01-03662	MXP ENID, LLC	PO0124889	FUEL	\$911.36
01-04319	NAPA AUTO PARTS-WAREHOUSE	PO0124879	WAREHOUSE PARTS 9/14	\$140.08
01-04614	OG&E ELECTRIC SERVICES	PO0124923	LINE RELOCATION/RUNWAY EXT	\$49,833.00
01-04619	LEARD & ASSOCIATES, INC.	PO0125032	PROFESSIONAL SERVICE	\$2,460.00
01-32760	INTEGRIS BASS OCCUP. MEDICINE	PO0125040	EMPLOYEE SCREENING	\$45.00
01-42400	AT & T	PO0124936	MONTHLY SERVICE 10/14	\$255.42
01-55120	QUILL CORPORATION, INC.	PO0124887	CALCULATOR ROLLS	\$27.44
01-55120	QUILL CORPORATION, INC.	PO0125011	COFFEE	\$56.10
01-80343	FENTRESS OIL COMPANY, INC.	PO0124988	OIL/ST	\$317.07
<b>AIRPORT TOTAL</b>				<b>\$85,142.93</b>

**FUND 22 DEPT 225 - GOLF**

01-00461	HOT SHOT POWER WASHING, INC.	PO0124942	KITCHEN EXHAUST MAINTENANCE	\$350.00
01-01338	J & P SUPPLY, INC.	PO0125003	TOWELS/GLOVES/AIR FRESHENER	\$287.44
01-01783	JP MORGAN CHASE	PO0125061	CHASE PAYMENT	\$1,160.01
01-01977	DAVIS PIPE & SUPPLY, INC.	PO0124975	FITTINGS	\$31.55
01-02208	SOONER PUBLISHING MARKETING & CREA	PO0124946	ADVERTISING	\$328.40
01-02446	JOHN DEERE FINANCIAL	PO0122680	MOWER LEASE 10/14	\$622.37
01-03735	PNC EQUIPMENT FINANCE	PO0122889	TURF MOWER LEASE 10/14	\$550.69
01-04173	DE LAGE PUBLIC FINANCE, LLC.	PO0122579	BLADE SHARPENER LEASE 10/14	\$377.15
01-44810	MICHAEL'S REFRIGERATION	PO0124943	ICE MACHINE MAINTENANCE	\$346.00
01-66210	YAMAHA MOTOR CORPORATION USA	PO0123466	GOLF CART LEASE 10/14	\$2,649.00
<b>GOLF TOTAL</b>				<b>\$6,702.61</b>

**FUND 30 DEPT 305 - STREET & ALLEY**

01-02470	DERWIN'S CONSTRUCTION	PO0124247	M-1403A SIDEWALK PROGRAM	\$5,466.10
01-60230	RICK LORENZ CONSTRUCTION	PO0120495	R-1401A 2014 STREET PROGRAM	\$74,108.36
<b>STREET &amp; ALLEY TOTAL</b>				<b>\$79,574.46</b>

**FUND 31 DEPT 230 - UTILITY BILLING**

01-04319	NAPA AUTO PARTS-WAREHOUSE	PO0124879	WAREHOUSE PARTS 9/14	\$139.71
<b>UTILITY BILLING TOTAL</b>				<b>\$139.71</b>

**FUND 31 DEPT 315 - E.M.A.**

01-03060	CENTRAL NATIONAL BANK	PO0125033	1987A SEMI-ANNUAL TRUSTEE FEES	\$2,329.75
01-04285	WALLACE, RICHARD	PO0124861	WC/SETTLEMENT	\$28,800.00
01-04609	BRYAN & ROBINSON, INC.	PO0124860	WC/ATTORNEY FEES	\$7,200.00
<b>E.M.A. TOTAL</b>				<b>\$38,329.75</b>

**FUND 31 DEPT 760 - SOLID WASTE SERVICES**

01-00146	CINTAS CORPORATION LOC. 624	PO0124871	SHOP TOWEL SERVICE 10/14	\$70.54
01-00146	CINTAS CORPORATION LOC. 624	PO0124973	SHOP TOWEL SERVICE 10/14	\$117.60
01-01017	ALBRIGHT STEEL & WIRE COMPANY	PO0124891	REBAR	\$111.09
01-01163	ADVANCED WATER SOLUTIONS	PO0124892	MONTHLY SERVICE 11/14	\$60.00
01-01783	JP MORGAN CHASE	PO0125061	CHASE PAYMENT	\$2,198.46
01-02043	RUSH TRUCK CENTERS	PO0125080	V238 TRASH TRUCK REPAIR	\$3,883.72
01-02082	AT&T MOBILITY	PO0125043	MONTHLY SERVICE 10/14	\$509.12
01-02466	FireCO OF OKLAHOMA, INC.	PO0124996	FIRE EXT INSPECTION	\$35.00
01-03022	CULLIGAN WATER CONDITION, INC.	PO0124974	BOTTLED WATER	\$6.00
01-03022	CULLIGAN WATER CONDITION, INC.	PO0124974	BOTTLED WATER	\$18.00
01-03022	CULLIGAN WATER CONDITION, INC.	PO0124974	WATER COOLER RENTAL 10/14	\$8.50
01-03107	CHEM-CAN SERVICES, INC.	PO0124971	PORTABLE TOILET RENTAL 11/14	\$164.00
01-03921	EXPRESS SCRIPTS, INC.	PO0124976	WC/MEDICAL	\$15.46

01-04033	DOLESE BROTHERS CO., INC.	PO0125070	CRUSHER RUN	\$1,000.63
01-04116	DOWNTOWN THREADS	PO0124983	LOGO SHIRTS (16)	\$597.30
01-04319	NAPA AUTO PARTS-WAREHOUSE	PO0124879	WAREHOUSE PARTS 9/14	\$66,156.96
01-04399	STIDHUM, ANTHONY	PO0124864	WC/MEDICAL	\$323.00
01-04399	STIDHUM, ANTHONY	PO0124921	WC/MEDICAL	\$323.00
01-04612	PHILLIPS & SONS TRUCKING, LLC	PO0124876	COMPACTOR RELOCATION	\$500.00
01-04617	HEALTHPORT TECHNOLOGIES, LLC	PO0124972	WC/MEDICAL	\$276.59
01-07102	GARFIELD R W D #5	PO0124874	MONTHLY SERVICE 10/14	\$47.80
01-19004	SHERWIN-WILLIAMS CO., INC.	PO0125012	PAINT/BRUSHES/PAIL	\$138.59
01-80246	ATWOODS	PO0124957	WELDING WIRE/STRAW BALES	\$583.03
<b>SOLID WASTE SERVICES TOTAL</b>				<b>\$77,144.39</b>

**FUND 31 DEPT 790 - WATER PRODUCTION**

01-01005	ALFALFA ELECTRIC COOPERATIVE	PO0124993	MONTHLY SERVICE 10/14	\$36,969.19
01-01783	JP MORGAN CHASE	PO0125061	CHASE PAYMENT	\$745.42
01-02082	AT&T MOBILITY	PO0124969	MONTHLY SERVICE 10/14	\$69.21
01-02525	PAGE PLUS, INC.	PO0124963	MONTHLY SERVICE 11/14	\$17.94
01-02859	FLUID EQUIPMENT COMPANY	PO0125060	CHLORINE PROBE	\$2,322.83
01-04319	NAPA AUTO PARTS-WAREHOUSE	PO0124879	WAREHOUSE PARTS 9/14	\$1,827.82
01-05012	ENID WINNELSON COMPANY, INC.	PO0125018	PVC PIPE/CAPS	\$471.98
01-08022	HUGHES LUMBER CO., LLC	PO0124959	MORTAR/TROWEL/PATCHER	\$23.17
01-13089	MERRIFIELD OFFICE SUPPLY	PO0125006	CHAIR	\$165.00
01-13223	M&M SUPPLY COMPANY	PO0125004	COUPLING/FITTINGS	\$561.60
01-42160	DUSTY'S MOBILE LOCK & KEY SHOP	PO0124945	PAD LOCKS (12)	\$132.00
01-50210	LOWE'S HOME CENTERS, INC.	PO0124947	TAPE INSULATION	\$62.68
01-55120	QUILL CORPORATION, INC.	PO0124887	TONER (2)	\$367.18
01-59360	FASTENAL COMPANY	PO0124995	DRILL BIT	\$15.07
01-80258	BRENNTAG SOUTHWEST, INC.	PO0123279	CHLORINE	\$3,144.00
01-80473	ACE HARDWARE-SOUTHERN HARDLINES	PO0124965	SEALANT/CLEANER	\$32.95
<b>WATER PRODUCTION TOTAL</b>				<b>\$46,928.04</b>

**FUND 31 DEPT 795 - WATER RECLAMATION SERVICES**

01-00917	HD SUPPLY WATERWORKS	PO0125079	METERS/SPLICE CONNECTORS	\$2,316.00
01-01783	JP MORGAN CHASE	PO0125061	CHASE PAYMENT	\$1,132.79
01-02082	AT&T MOBILITY	PO0125043	MONTHLY SERVICE 10/14	\$353.56
01-02470	DERWIN'S CONSTRUCTION	PO0124979	REPAIR/RETAINING WALL/E MAPLE	\$219.00
01-02470	DERWIN'S CONSTRUCTION	PO0124992	STREET/CURB/GUTTER REPAIR	\$2,646.65
01-02470	DERWIN'S CONSTRUCTION	PO0125047	STREET/CURB/GUTTER REPAIR	\$5,325.55
01-04319	NAPA AUTO PARTS-WAREHOUSE	PO0124879	WAREHOUSE PARTS 9/14	\$17,197.20
01-04563	XPRESS WELLNESS, LLC	PO0124980	WC/MEDICAL	\$98.60
01-80246	ATWOODS	PO0124957	BOOTS/J LOWRIE	\$125.00
<b>WATER RECLAM SERVICES TOTAL</b>				<b>\$29,414.35</b>

**FUND 31 DEPT 799 - WASTE WATER MANAGEMENT**

01-00146	CINTAS CORPORATION LOC. 624	PO0124915	SHOP TOWEL SERVICE 10/14	\$154.50
01-01178	ACCURATE, INC.	PO0124875	SAMPLE ANALYSIS	\$175.00
01-01178	ACCURATE, INC.	PO0124875	BIMONTHLY TESTING	\$205.00
01-01338	J & P SUPPLY, INC.	PO0124885	PAPER TOWELS	\$36.67
01-03022	CULLIGAN WATER CONDITION, INC.	PO0124884	FILTERS/SOLAR SALT	\$140.00
01-03022	CULLIGAN WATER CONDITION, INC.	PO0124884	FILTERS/SOLAR SALT	\$144.00
01-07036	GRAINGER, INC.	PO0124877	BATTERY/EYE WASH STATION	\$316.06
01-38030	DAL SECURITY, INC.	PO0124883	MONTHLY MONITORING 10/14	\$25.00
01-80258	BRENNTAG SOUTHWEST, INC.	PO0124709	POLYMER	\$3,331.32
<b>WASTE WATER MGMT TOTAL</b>				<b>\$4,527.55</b>

**FUND 32 DEPT 325 - E.E.D.A.**

01-00172	GARFIELD COUNTY ASSESSOR	PO0125029	M-1511A 2313 C COURT/TAXES	\$330.00
01-80271	NICHOLAS REAL ESTATE	PO0124858	M-1511A PROP PURCH/710/714 A	\$80,501.00
01-80271	NICHOLAS REAL ESTATE	PO0124869	M-1511A PROP PURCH/2313/2317 C	\$74,929.00
<b>E.E.D.A. TOTAL</b>				<b>\$155,760.00</b>

**FUND 40 DEPT 405 - CAPITAL IMPROVEMENT**

01-01017	ALBRIGHT STEEL & WIRE COMPANY	PO0124968	P-1403C REBAR/EXPANSION JOINTS	\$939.90
01-01783	JP MORGAN CHASE	PO0125061	CHASE PAYMENT	\$1,433.43
01-04033	DOLESE BROTHERS CO., INC.	PO0124917	M-1501A SCREENINGS/CONCRETE	\$407.72
01-04033	DOLESE BROTHERS CO., INC.	PO0125070	M-1501A SCREENINGS/CONCRETE	\$19,782.95

01-04419	SEXTON CONSTRUCTION	PO0124949	M-1404A DEPOT ROOF REPLACEMENT	\$2,635.00
01-04419	SEXTON CONSTRUCTION	PO0120945	M-1404A DEPOT ROOF REPLACEMENT	\$11,350.00
01-04562	ELI BRIDGE COMPANY	PO0125048	P-1403D PROFESSIONAL SERVICES	\$11,445.00
01-04565	CIMMARON SOD	PO0124022	M-1410A SOD DELIVERY/INSTALL	\$22,620.00
01-08022	HUGHES LUMBER CO., LLC	PO0124916	M-1501A LUMBER/STAKES	\$93.03
01-08022	HUGHES LUMBER CO., LLC	PO0124959	M-1501A LUMBER	\$89.82
01-08022	HUGHES LUMBER CO., LLC	PO0124959	P-1403C LUMBER/PLYWOOD	\$241.68
01-08022	HUGHES LUMBER CO., LLC	PO0124991	P-1403C LUMBER	\$1,556.85
01-20022	TRAFFIC SIGNAL INC-OKLA	PO0120948	M-1401A TRAIL CROSSING SIGNAL	\$54,722.17
			<b>CAPITAL IMPROVEMENT TOTAL</b>	<b>\$127,317.55</b>

**FUND 41 DEPT 415 - STREET IMPROVEMENT**

01-12007	LUCKINBILL, INC.	PO0121363	W-1409A WATER LINE RELOCATION	\$173,289.03
			<b>STREET IMPROVEMENT TOTAL</b>	<b>\$173,289.03</b>

**FUND 42 DEPT 425 - SANITARY SEWER FUND**

01-12007	LUCKINBILL, INC.	PO0121364	S-1402B SAN SEWER INSPECTIONS	\$31,600.34
			<b>SANITARY SEWER FUND TOTAL</b>	<b>\$31,600.34</b>

**FUND 43 DEPT 435 - STORMWATER FUND**

01-02736	BYRIN'S LAWN CARE	PO0124248	TREE REMOVAL	\$1,200.00
01-02979	NOWAK CONSTRUCTION, INC.	PO0121858	F-1307B DETENTION OVERFLOW	\$1,771.35
01-39700	GARFIELD CO. LEGAL NEWS	PO0124997	F-1307A PUBLICATIONS	\$336.40
			<b>STORMWATER FUND TOTAL</b>	<b>\$3,307.75</b>

**FUND 44 DEPT 445 - WATER CAP. IMPROVEMENT FUND**

01-01918	GUERNSEY	PO0095773	W-1004A WATER SOURCE EXPANSION	\$7,700.00
01-04232	GABLE GOTWALS	PO0125073	W-1304B PROFESSIONAL SERVICES	\$5,627.50
01-04250	MITCHELL & DeCLERCK, PLLC	PO0125007	W-1304A PROFESSIONAL SERVICES	\$12,400.00
01-46000	TRAYNOR, LONG & WYNNE, PC	PO0125016	W-1304A PROFESSIONAL SERVICES	\$483.00
			<b>WATER CAP. IMPROVE FUND TOTAL</b>	<b>\$26,210.50</b>

**FUND 50 DEPT 505 - 911**

01-01783	JP MORGAN CHASE	PO0125061	CHASE PAYMENT	\$109.00
01-42400	AT & T	PO0124900	MONTHLY SERVICE 10/14	\$1,788.96
01-66190	AT&T	PO0125068	MONTHLY SERVICE 10/14	\$10,342.30
			<b>911 TOTAL</b>	<b>\$12,240.26</b>

**FUND 51 DEPT 515 - POLICE**

01-01367	ONELINK WIRELESS	PO0123402	RADIO/ANTENNA/CONNECTOR	\$5,294.00
01-01783	JP MORGAN CHASE	PO0125061	CHASE PAYMENT	\$828.83
01-02082	AT&T MOBILITY	PO0125077	MONTHLY SERVICE 10/14	\$1,612.40
01-02750	AQUA EXPRESS NORTH, LLC	PO0124909	CAR WASHES (39)	\$156.00
01-03569	GRIMSLEY'S, INC.	PO0124911	TISSUE/GLOVES/TOWELS/LINERS	\$643.40
01-04157	CONSOLIDATED ELECTRICAL DISTRIBUTOR	PO0124898	LAMPS 515	\$59.94
01-04319	NAPA AUTO PARTS-WAREHOUSE	PO0124879	WAREHOUSE PARTS 9/14	\$6,803.22
01-04620	FRAZEE, ZEKE	PO0125036	TUITION SCHOLARSHIP	\$955.27
01-05015	ENID THERAPY CENTER	PO0124868	WC/MEDICAL	\$69.04
01-13145	MID-AMERICA WHOLESale, INC.	PO0124910	COFFEE/SUGAR	\$202.33
01-16004	PDQ PRINTING	PO0124903	ENVELOPES (1000)	\$170.00
01-16004	PDQ PRINTING	PO0125075	ID CARD	\$5.00
01-20108	TOTAL COM, INC.	PO0124899	RADIO REPAIR	\$111.00
01-32760	INTEGRIS BASS OCCUP. MEDICINE	PO0125040	EMPLOYEE SCREENING	\$40.00
01-37770	ENID CHAPTER AFA #214	PO0124904	COMMUNITY PARTNER APPLICATION	\$90.00
01-49470	CLAY'S COLLISION CENTER	PO0124908	REPAIR/2005 FORD CROWN/PANEL	\$915.70
01-50210	LOWE'S HOME CENTERS, INC.	PO0124902	CLEANER/SCREWS/MOP/BRUSH	\$80.58
01-53320	OK ANIMAL CONTROL ASSOC.	PO0124901	FALL SEMINAR/A ELDER	\$150.00
01-70950	COPIERS PLUS, INC.	PO0124906	COPIER OVERAGE 10/14	\$280.00
01-79290	SIGN SHACK THE	PO0124905	DECAL REPAIR	\$185.00
			<b>POLICE TOTAL</b>	<b>\$18,651.71</b>

**FUND 52 DEPT 525 - C.I.C.**

01-02082	AT&T MOBILITY	PO0125077	MONTHLY SERVICE 10/14	\$174.48
			<b>C.I.C. TOTAL</b>	<b>\$174.48</b>

**FUND 60 DEPT 605 - EECCH**

01-01783	JP MORGAN CHASE	PO0125061	CHASE PAYMENT	\$68.19
01-02790	GLOBAL SPECTRUM	PO0124990	ROCK	\$382.50
01-15125	OK GAS & ELECTRIC	PO0124939	MONTHLY SERVICE 10/14	\$17,004.62
01-15125	OK GAS & ELECTRIC	PO0124940	MONTHLY SERVICE 10/14	\$223.39
			<b>EECCH TOTAL</b>	<b>\$17,678.70</b>

**FUND 65 DEPT 655 - FIRE**

01-00540	SIMONS PETROLEUM, LLC	PO0125024	ANTIFREEZE	\$343.75
01-00612	PHYSICIANS GROUP, LLC	PO0124981	WC/MEDICAL	\$644.74
01-00612	PHYSICIANS GROUP, LLC	PO0125066	WC/MEDICAL	\$2,195.66
01-01001	A & B RADIATOR SERVICE	PO0125025	V1031 RADIATOR	\$796.00
01-01647	BASS BAPTIST HEALTH CENTER	PO0124978	WC/MEDICAL	\$97.60
01-01783	JP MORGAN CHASE	PO0125061	CHASE PAYMENT	\$3,783.96
01-01800	COMMUNITY HOSPITAL, LLC	PO0125065	WC/MEDICAL	\$4,440.57
01-02082	AT&T MOBILITY	PO0125028	MONTHLY SERVICE 11/14	\$23.11
01-02146	SPRINT NEXTEL	PO0125027	HAZMAT WIFI/AIR CARD	\$19.09
01-02466	FireCO OF OKLAHOMA, INC.	PO0125026	FIRE EXT INSPECTION	\$105.00
01-03099	CHIEF FIRE & SAFETY CO., INC.	PO0125022	GASKETS/EXPANSION RINGS	\$216.00
01-04256	GOOD EARTH PRODUCTS, INC.	PO0125023	CLEANER	\$397.03
01-32760	INTEGRIS BASS OCCUP. MEDICINE	PO0125040	EMPLOYEE SCREENING	\$374.00
01-37890	OK STATE UNIVERSITY	PO0125030	FIRE OFFICER TRAINING	\$275.00
01-79980	PIONEER BUSINESS SOLUTION	PO0125031	MONTHLY SERVICE 11/14	\$32.25
			<b>FIRE TOTAL</b>	<b>\$13,743.76</b>

**FUND 99 DEPT 995 - EPTA**

01-01163	ADVANCED WATER SOLUTIONS	PO0125051	WATER COOLER RENTAL 11/14	\$23.55
01-01783	JP MORGAN CHASE	PO0125061	CHASE PAYMENT	\$65.42
01-02082	AT&T MOBILITY	PO0125053	MONTHLY SERVICE 10/14	\$284.27
01-02594	PIONEER TELEPHONE-MAINE	PO0125049	MONTHLY SERVICE 10/14	\$20.22
01-04319	NAPA AUTO PARTS-WAREHOUSE	PO0124879	WAREHOUSE PARTS 9/14	\$4,475.16
01-47300	OK TURNPIKE AUTHORITY	PO0125062	PIKE PASS	\$13.50
			<b>EPTA TOTAL</b>	<b>\$4,882.12</b>

**FUND 70 DEPT 705 - CDBG**

70-01783	JP MORGANCHASE COMMERCIAL CARD	PO0125071	CHASE PAYMENT	\$89.35
70-04377	JACKSON WRECKING & DEMOLITION, LLC	PO0124023	B-11(365) DEMO/1602 S 3RD	\$3,700.00
70-04377	JACKSON WRECKING & DEMOLITION, LLC	PO0124144	B-11 (365) DEMO/530 E BROADWAY	\$2,475.00
			<b>CDBG TOTAL</b>	<b>\$6,264.35</b>

**COMBINED BREAKDOWN OF TOTALS**

EMA	\$196,483.79
EEDA	\$155,760.00
REMAINING FUNDS	\$2,406,712.21
<b>TOTAL CLAIMS</b>	<b>\$2,758,956.00</b>

# PURCHASING CARD CLAIMS LIST

11-18-2014

**FUND 10 DEPT 100 - ADMINISTRATIVE SERVICES**

EXECUTIVE CARPET CLEAN	PO0125071	CARPET CLEANING	371.00
LOWES #00205*	PO0125071	INCENTIVE AWARDS	538.83
MCKINLEY HARDWOODS	PO0125071	LUMBER	961.00
STAPLES 00106633	PO0125071	LABEL/CARTRIDGE/WIRELESS MOUSE	92.25
<b>ADMINISTRATIVE SERVICES TOTAL</b>			<b>1,963.08</b>

**FUND 10 DEPT 110 - HUMAN RESOURCES**

PREHIRE SCREENING SERV	PO0125071	BACKGROUND SCREENINGS (8)	449.00
SCHIEBERS DONUTS & DEL	PO0125071	MEAL/LONG TERM EMP MEETING	132.80
SQ *LANEY'S CUPCAKES A	PO0125071	HALLOWEEN CUPCAKES	70.00
STAPLES 00106633	PO0125071	INCENTIVE AWARDS	25.97
T J MAXX #1339	PO0125071	INCENTIVE AWARDS	139.75
USPS POSTAL ST66100207	PO0125071	STAMPS (100)	50.30
WALGREENS #5531	PO0125071	HALLOWEEN CANDY	17.98
<b>HUMAN RESOURCES TOTAL</b>			<b>885.80</b>

**FUND 10 DEPT 120 - LEGAL SERVICES**

AT&T DATA	PO0125071	IPAD DATA PLAN 10/14	25.00
OFFICE DEPOT #1079	PO0125071	ENVELOPES/FASTENERS/CALENDAR	224.58
<b>LEGAL SERVICES TOTAL</b>			<b>249.58</b>

**FUND 10 DEPT 140 - SAFETY**

AT&T*BILL PAYMENT	PO0125071	IPAD DATA PLAN (2 MO)	61.22
STAPLES 00106633	PO0125071	LAMINATING POUCHES/INK	58.72
WESTERN SIZZLIN	PO0125071	MEALS (2)/SAFETY TRAINING	39.86
WINCHELL'S DONUTS	PO0125071	MEAL (15)/SAFETY MEETING	13.48
<b>SAFETY TOTAL</b>			<b>173.28</b>

**FUND 10 DEPT 200 - GENERAL GOVERNMENT**

CHICK-FIL-A #02804	PO0125071	MEAL/COMMISSION MEETING	218.55
RENAISSANCE HOTELS	PO0125071	LODGING/OML CONF/R JANZEN CREDIT PENDING	34.16
UNITED SUPERMARKET 3	PO0125071	MEAL/COMMISSION MEETING	12.98
WM SUPERCENTER #499	PO0125071	VENDING MACHINE SNACKS	122.67
<b>GENERAL GOVERNMENT TOTAL</b>			<b>388.36</b>

**FUND 10 DEPT 210 - ACCOUNTING**

ACCOUNTANCY BOARD	PO0125071	CONTINUING ED/J GILBERT	51.00
PAYPAL *OKLAHOMAMUN	PO0125071	OML JOB POSTING	10.00
PLAYA AZUL ENID	PO0125071	MEAL (7)/DEPT MEETING	75.00
<b>ACCOUNTING TOTAL</b>			<b>136.00</b>

**FUND 10 DEPT 250 - INFORMATION TECHNOLOGY**

LIVEPERSON, INC	PO0125071	ON LINE CHAT COE WEB SITE	159.00
PAYPAL *SERVERSUPPL SE	PO0125071	CISCO FIBER MODULE	149.12
T-SHIRT & MONOGRAMMING	PO0125071	LOGO JACKET (3)/LOGO SHIRTS (3)	303.78
<b>INFORMATION TECHNOLOGY TOTAL</b>			<b>611.90</b>

**PURCHASING CARD CLAIMS LIST**

11-18-2014

**FUND 10 DEPT 300 - COMMUNITY DEVELOPMENT**

FAIRFIELD INN&SUITES O	PO0125071	LODGING/SWCCC CONF/C BAUER	378.00
<b>COMMUNITY DEVELOPMENT TOTAL</b>			<b>378.00</b>

**FUND 10 DEPT 400 - ENGINEERING**

JUMBO FOODS	PO0125071	WATER/BROADWAY TRAIL PUBLIC MEETING	69.01
TIGER SUPPLIES	PO0125071	LEVEL	216.00
<b>ENGINEERING TOTAL</b>			<b>285.01</b>

**FUND 10 DEPT 700 - PUBLIC WORKS MGMT**

ACE HARDWARE	PO0125071	TRIMMER LINE	15.05
ADVANCED WATER SOLUTIO	PO0125071	WATER COOLER RENTAL 10/14	49.00
AMAZON.COM	PO0125071	BACKUP CAMERAS (3)	189.69
AMERICAN 00175051006222	PO0125071	AIRFARE/WWETT CONF/J NEAL	394.20
APL* ITUNES.COM/BILL	PO0125071	PDF SOFTWARE	9.99
APPLEBEE'S 08000119	PO0125071	MEAL (2)/DEPT MEETING	26.37
AT&T O519 8327	PO0125071	PHONE CASE/PHONE CHARGERS	148.40
BRADFORD INDUS SUPPLY	PO0125071	TIN SNIPS/FILTERS	91.26
COLE INC	PO0125071	WWETT CONF/R CAMP	105.00
FAMILY DOLLAR #2065	PO0125071	WIPES	5.50
HOBBY-LOBBY #0008	PO0125071	AWARD FRAME	12.99
JUMBO FOODS	PO0125071	BBQ SAUCE/CHARCOAL	86.25
KEURIG GREEN MOUNTAIN	PO0125071	COFFEE	134.94
LITTLE CAESARS 0129 00	PO0125071	MEAL (11)/DEPT MEETING	48.16
LOWES #00205*	PO0125071	SCREWS/FENCE PICKETS (16)	189.43
MISSION REPAIR LLC	PO0125071	IPAD SCREEN REPAIR	88.19
NATIONAL PEN CO LLC	PO0125071	MONOGRAMMED PENS (150)	115.40
RADIOSHACK COR00166611	PO0125071	VGA SPLITTER CABLE	36.99
SAVE A LOT #24925	PO0125071	MEAL/ELI BRIDGE/FERRIS WHEEL	65.01
SOUTHWES 5262458799205	PO0125071	AIRFARE/WWETT CONF/R CAMP	689.40
STAPLES 00106633	PO0125071	MONITORS/PAPER/IPAD COVERS	599.40
TRAVELOCITY.COM	PO0125071	AIRFARE/WATER CONVENTION/J NEAL	16.23
UPS*1Z37T71E0399280086	PO0125071	SHIPPING FEES	10.13
WAL-MART #0499	PO0125071	VACUUM/PLATES	175.45
WHITTON SUPPLY CO	PO0125071	PAD/PORTABLE BAND SAW/DRILL	648.37
WINCHELL'S DONUTS	PO0125071	MEAL/ODEQ MEETING	21.58
<b>PUBLIC WORKS MGMT TOTAL</b>			<b>3,972.38</b>

**FUND 10 DEPT 710 - FLEET MGMT**

NAPA TRACS	PO0125071	ONLINE VEHICLE INFO 11/14	132.00
STAPLES 00106633	PO0125071	PRINTER INK/DRY ERASE BOARD	136.96
<b>FLEET MGMT TOTAL</b>			<b>268.96</b>

**FUND 10 DEPT 730 - PARKS & RECREATION**

ACE HARDWARE	PO0125071	KEYS CUT/KELLET PARK	6.95
AT&T DATA	PO0125071	IPAD DATA PLAN 10/14	30.00
ATW OF ENID # 01	PO0125071	JACKET/R AVILEZ	159.98
ATW OF ENID # 01	PO0125071	SAFETY VESTS	29.98
CITY OF ENID GVT XPRES	PO0125071	TEST TRANSACTION	1.00
ENID WINNELSON CO	PO0125071	METERED FAUCET/COUPLINGS	309.57



# PURCHASING CARD CLAIMS LIST

11-18-2014

INDUSTRIAL MATERIALS	PO0125071	ENTRY DOOR HANDLE	90.00
JUMBO FOODS	PO0125071	MEAL/DEPT MEETING	53.95
LOCKE SUPPLY - ENID	PO0125071	PIPE PLUG	0.82
LOWES #00205*	PO0125071	SCREWS/STAKES/PAINT/GRINDER	1,297.26
M&M SUPPLY CO.	PO0125071	WATER CONNECTION PARTS	54.94
MUNN SUPPLY	PO0125071	TORCH REPAIR EQUIPMENT	10.92
RAMSEYS WHATEVER ST	PO0125071	PLUMBING PARTS/NUT DRIVER SET	11.10
SHERWIN WILLIAMS #7185	PO0125071	PAINT	467.89
SPRINKLERWAREHOUSE.	PO0125071	FLOW CONTROL VALVE/CONTROLLER	275.26
STAPLES 00106633	PO0125071	INK PENS	48.95
STUART C IRBY	PO0125071	FITTINGS/CONDUIT	578.02
SWANK MOTION PICTURES	PO0125071	(CREDIT) MOVIE CANCELLED	(324.00)
WM SUPERCENTER #499	PO0125071	UTENSILS/PLATES	12.96
<b>PARKS &amp; RECREATION TOTAL</b>			<b>3,115.55</b>

**FUND 10 DEPT 740 - STRMWTR & ROADWAY MAINT**

AMAZON.COM	PO0125071	SMART LEVEL	129.70
ENID IRON & METAL CO	PO0125071	PLATE	212.55
<b>STRMWTR &amp; ROADWAY MAINT TOTAL</b>			<b>342.25</b>

**FUND 10 DEPT 750 - TECHNICAL SERVICES**

FASTENAL COMPANY01	PO0125071	SIGN HARDWARE	12.39
HOBBY-LOBBY #0008	PO0125071	CHILI COOK OFF SUPPLIES	27.94
HUGHES LUMBER COMPANY	PO0125071	TAR	140.22
MID AMERICA FOOD DISTR	PO0125071	CHILI COOK OFF SUPPLIES	18.45
PINKLEY SALES COMPANY	PO0125071	LIGHTS/PEDESTRIAN SIGN/FANS	1,320.67
SIGNWAREHOUSE.COM	PO0125071	LAMINATING FILM/INK	429.99
T-SHIRT & MONOGRAMMING	PO0125071	LOGO JACKET/R ROBBINS	52.73
<b>TECHNICAL SERVICES TOTAL</b>			<b>2,002.39</b>

**FUND 10 DEPT 900 - LIBRARY**

AMAZON MKTPLACE PMTS	PO0125071	LOUNGE CHAIRS (27)	975.31
AMAZON.COM	PO0125071	BOOKS/BOOK CLUB	165.48
AMAZON.COM	PO0125071	WINTER READING PRIZES	250.00
AMER LIB ASSOC-CAREER	PO0125071	ALA CONF REGISTRATION/J MESSINA	85.00
ATHEY LUMBER COMPANY	PO0125071	DRYWALL/MUD/TAPE	81.42
ATHEY LUMBER COMPANY	PO0125071	METAL STUDS/TRACK/SCREWS	328.96
AUDIBLE	PO0125071	AUDIO BOOK	14.95
CENTER POINT LARGE PRI	PO0125071	BOOKS (22)	464.94
DART/TARTAN/MCNAUGH	PO0125071	BOOKS (135)	1,866.21
ENRIQUES RESTAURANT	PO0125071	MEAL (4)/ODL TRAINING	51.75
HAMPTON INN	PO0125071	LODGING/FESTIVAL OF THE BOOKS/G CUMPSTON	89.00
HASTINGS 9675 ENID 903	PO0125071	BOOKS	31.95
HOBBY-LOBBY #0008	PO0125071	TURKEY DISPLAY/PHOTO	204.83
INDUSTRIAL MATERIALS	PO0125071	DOOR/JAMB/HINGES	430.00
JUMBO II LLC	PO0125071	HOT DOG BUNS/WATER/HOT DOGS	9.53
LOVESAC - 1045	PO0125071	CHAIR INSERTS	30.90
MERRIFIELD OFFICE PLUS	PO0125071	BOOK	11.00
NSUBAC BKST #7240	PO0125071	BOOKS/TEEN PRIZES	37.90
OKLA 00 OF 00	PO0125071	TECH SERVICES WORKSHOP (3)	195.00

# PURCHASING CARD CLAIMS LIST

11-18-2014

PAYPAL *TERRIFICTEA	PO0125071	PIG14-1 FEED/OLIVIA	51.90
PBD ALA-GRAPH EDITIONS	PO0125071	BOOKMARKS/CIRCULATION	74.00
PETSMART INC 2427	PO0125071	PIG14-1 PADS/LITTER BOX/LITTER	123.17
RECORDED BOOKS	PO0125071	AUDIO BOOKS (16)	777.57
SCHIEBERS DONUTS & DEL	PO0125071	MEAL (20)/DEPT MEETING	15.00
SQ *GOBEN'S GOODIES	PO0125071	HALLOWEEN CANDY	125.00
STAPLES 00106633	PO0125071	POSTER PRINTING	9.99
STARPLEX	PO0125071	MOVIE TICKETS/PRIZES/PROGRAMS	259.95
STONEHILL GRILL - MIAM	PO0125071	MEAL/DIRECTORS COUNCIL/J CHAMPION	10.00
TINYPRINTS.COM	PO0125071	THANK YOU CARDS (40)	55.29
UNITED SUPERMARKET 3	PO0125071	PEANUT BUTTER/FLOUR/OATS	12.57
USPS 39282704133607748	PO0125071	SHIPPING FEES	6.49
ZIOS ITALIAN KITCHEN 6	PO0125071	MEAL/FESTIVAL OF BOOKS/G CUMPSTON	14.29
<b>LIBRARY TOTAL</b>			<b>6,859.35</b>

**FUND 10 DEPT 955 - CAPITAL ASSETS & PROJECTS**

B & H PHOTO-VIDEO-MO/T	PO0125071	EQUIPMENT RACK/ETN	284.07
<b>CAPITAL ASSETS &amp; PROJECTS TOTAL</b>			<b>284.07</b>

**FUND 20 DEPT 205 - AIRPORT**

AIRCRAFT SPRUCE AND SP	PO0125071	AVGAS REFUELING MAT	92.28
LOCKE SUPPLY WHC ENID	PO0125071	TERMINAL AIR FILTERS	63.98
OREILLY AUTO 00001883	PO0125071	JUMPER CABLES	49.99
PAYPAL *LAWNCUTTERS	PO0125071	POWER WASHER PUMP PLUGS	26.88
QTPOD.COM	PO0125071	SELF SERVE WARRANTY	595.00
RAMSEYS WHATEVER ST	PO0125071	DIESEL TANK PIPE	5.50
<b>AIRPORT TOTAL</b>			<b>833.63</b>

**FUND 22 DEPT 225 - GOLF**

ASSOCIATED SUPPLY COMP	PO0125071	COPIER INK	499.95
AUTOPAY/DISH NTWK	PO0125071	MONTHLY DISH SERVICE 10/14	222.00
JCPENNEY 2121	PO0125071	JEANS/M LEAGUE	99.95
LOWES #00205*	PO0125071	PAINT/SPRAYER/BRUSHES/LINERS	263.16
SUDDENLINK-NAT'L SITE	PO0125071	MONTHLY INTERNET SERVICE 10/14	74.95
<b>GOLF TOTAL</b>			<b>1,160.01</b>

**FUND 31 DEPT 760 - SOLID WASTE**

2000 CED	PO0125071	FIXTURES/SQUARE BOXES/COVERS	949.28
ACE HARDWARE	PO0125071	VINYL HOSE	4.74
APL* ITUNES.COM/BILL	PO0125071	IPAD PDF SOFTWARE	29.97
ATW OF ENID # 01	PO0125071	COVERALLS/J BURDG	99.99
BB MACHINE & SUPPLY IN	PO0125071	ADAPTER	40.73
FASTENAL COMPANY01	PO0125071	EYE BOLTS/WASHERS/NUTS	12.34
LOWES #00205*	PO0125071	SCREWS	9.88
SAFETY VISION	PO0125071	BACK UP CAMERAS (2)	990.00
STAPLES 00106633	PO0125071	STICKY NOTES/HIGHLIGHTERS/TAPE	35.08
UNITED SUPERMARKET 3	PO0125071	TOILET PAPER	26.45
<b>SOLID WASTE TOTAL</b>			<b>2,198.46</b>

## PURCHASING CARD CLAIMS LIST

11-18-2014

**FUND 31 DEPT 790 - WATER PRODUCTION**

LOWES #00205*	PO0125071	INSULATION/HEAT TAPE	459.13
SEARS ROEBUCK 2291	PO0125071	PLIERS/HEX KEY/WRENCHES	286.29
<b>WATER PRODUCTION TOTAL</b>			<b>745.42</b>

**FUND 31 DEPT 795 - WATER RECLAMATION SVS**

AIRGAS CENTRAL	PO0125071	RAPAROUND	21.37
DEPT OF ENV QUALITY	PO0125071	ODEQ CERTIFICATION EXAM (3)	372.00
ENID IRON & METAL CO	PO0125071	PIPE/ROD	455.55
KINNUNEN SALES & RENT	PO0125071	DRILL BITS SET/RECIPROCATING BLADES	211.79
LOWES #00205*	PO0125071	CONCRETE MIX	23.88
MUNN SUPPLY	PO0125071	GRINDING WHEELS/CUT OFF WHEELS	48.20
<b>WATER RECLAMATION SVS TOTAL</b>			<b>1,132.79</b>

**FUND 40 DEPT 405 - CAP. IMPROVEMENT**

ATW OF ENID # 01	PO0125071	M-1501A TOOLBOX/HOSE REEL/TOW ADAPTER	429.68
HARBOR FREIGHT CATALOG	PO0125071	M-1501A PORTABLE SAND BLASTER	153.25
KINNUNEN SALES & RENT	PO0125071	P-1403C CONCRETE CURE	526.42
LOWES #00205*	PO0125071	M-1501A SCREW DRIVERS/STRIPING WAND/TWINE	139.64
LOWES #00205*	PO0125071	P-1403C BRICK RUBS/NAILS/REBAR	184.44
<b>CAP. IMPROVEMENT TOTAL</b>			<b>1,433.43</b>

**FUND 50 DEPT 505 - 911**

PUBLIC SAFTY RECRUIT.C	PO0125071	911 TEST MATERIAL	109.00
<b>911 TOTAL</b>			<b>109.00</b>

**FUND 51 DEPT 515 - POLICE**

CABELAS RETAIL ALLEN	PO0125071	MEAL/SUPERVISOR SCHOOL/T DOYLE	8.65
EL QUESO	PO0125071	MEAL/SUPERVISOR SCHOOL/T DOYLE	9.49
ENRIQUES RESTAURANT	PO0125071	MEAL (3)/FORENSIC SCHOOL	30.25
FREDDY'S FROZEN #6002	PO0125071	MEAL/TROOPER HAMPTON/CLASS INST.	8.01
GALLS INTERN*	PO0125071	BELT/R GRASSINO	23.80
HEAD COUNTRY BAR-B-	PO0125071	MEAL (3)/FORENSIC SCHOOL	37.86
HOBBY-LOBBY #0008	PO0125071	PLAQUE	32.19
HOLIDAY INN EXPRESS-EN	PO0125071	LODGING/CLASS INSTRUCTOR/TROOPER HAMPTON	109.00
LOVE S COUNTRY00002196	PO0125071	V2185 FUEL/CLEET/K EVERLY	57.65
LOVE S COUNTRY00002196	PO0125071	V96 FUEL/CLEET TRAINING/D HORTON	27.84
MCDONALD'S F7778	PO0125071	MEAL/AC SEMINAR/A ELDER	2.78
MCDONALD'S F7819	PO0125071	MEAL/TROOPER HAMPTON/CLASS INST	6.37
QDOBA MEXICAN GRILL #1	PO0125071	MEAL/SUPERVISOR SCHOOL/T DOYLE	15.48
QUALITY INN & SUITES	PO0125071	LODGING/AC SEMINAR/A ELDER	158.00
SAFETY GEAR CORPORATIO	PO0125071	UNIFORM/PARKING COMPLIANCE/R GRASSINO	102.03
SALS PIZZA PLANO	PO0125071	MEAL/SUPERVISOR SCHOOL/T DOYLE	8.60
SALTGRASS - PLANO	PO0125071	MEAL/SUPERVISOR SCHOOL/T DOYLE	31.59
SANGER CONOCO	PO0125071	V2101 FUEL/SUPER SCHOOL/T DOYLE	32.00
SHERWIN WILLIAMS #7185	PO0125071	PAINT	56.69
SUBWAY 00438010	PO0125071	MEAL/SUPERVISOR SCHOOL/T DOYLE	7.31
TIRES PLUS 517917	PO0125071	V2061 ALIGNMENT	59.99
USPS 39282704133607748	PO0125071	SHIPPING FEES	3.25
<b>POLICE TOTAL</b>			<b>828.83</b>

## PURCHASING CARD CLAIMS LIST

11-18-2014

**FUND 60 DEPT 605 - EECCH**

ENID WINNELSON CO	PO0125071	CUTTER/TEST PLUGS	68.19
		<b>EECCH TOTAL</b>	<b>68.19</b>

**FUND 65 DEPT 655 - FIRE**

183 BUILD-OKLAHOMA	PO0125071	M-1409 CEILING TILES	2,200.40
ACE HARDWARE	PO0125071	KEYS	2.78
ATW OF ENID # 01	PO0125071	WORKOUT MATS	218.92
BRADFORD INDUS SUPPLY	PO0125071	M-1409 DUCT/FOIL TAPE/DUCT KNIFE	138.44
ENID WINNELSON CO	PO0125071	PVC PIPE/CLEANER/GLUE	205.74
FAIRFIELD INN&SUITES E	PO0125071	LODGING/OKIAAI CONF/K HELMS	174.00
FAMILY DOLLAR #2065	PO0125071	LAUNDRY DETERGENT	29.50
LOCKE SUPPLY WHC ENID	PO0125071	M-1409 FINGER SAVERS	20.98
LOWES #00205*	PO0125071	INSULATION/KNIVES	148.88
LOWES #00205*	PO0125071	M-1409 CEILING TEES	171.42
MCDONALD'S F35035	PO0125071	MEAL/TRAINER CONF/KIERNAN	5.25
MSC CLASS C	PO0125071	SHOP CABINET	190.52
MSC CLASS C	PO0125071	V1040 WIRING/CABLE LOOM	100.16
SANTA FE CATTLE COMPAN	PO0125071	MEAL/TRAINER CONF/KIERNAN	22.37
SHERWIN WILLIAMS #7185	PO0125071	M-1409 DROP CLOTHES	44.48
TOTAL DIABETES SUPPLY	PO0125071	GLUCOSE METERS/CONTROL SOLUTION	78.59
USPS 39282704133607748	PO0125071	SHIPPING FEES	7.71
WAL-MART #0499	PO0125071	BOXES	23.82
		<b>FIRE TOTAL</b>	<b>3,783.96</b>

**FUND 70 DEPT 705 - CDBG**

KATYS PANTRY	PO0125071	MEAL (8)/CDBG FUNDING MEETING	59.35
SCHIEBERS DONUTS & DEL	PO0125071	MEAL (8)/CDBG FUNDING MEETING	30.00
		<b>CDBG TOTAL</b>	<b>89.35</b>

**FUND 99 DEPT 995 - EPTA**

CVS/PHARMACY #10102	PO0125071	CLEANER/WIPES/CANDY	65.42
		<b>EPTA TOTAL</b>	<b>65.42</b>

<b>JP MORGANCHASE CLAIMS LIST TOTAL</b>			<b>\$ 34,364.45</b>
---	--	--	---------------------